

**TECHNICAL MANUAL**  
**OPERATOR'S, ORGANIZATIONAL, DIRECT SUPPORT**  
**AND GENERAL SUPPORT MAINTENANCE MANUAL**  
**INCLUDING REPAIR PARTS AND SPECIAL TOOLS LIST**

**FOR**

**TRUCK, FIREFIGHTING DRY CHEMICAL AFF**  
**NSN 4210-00-484-5729**

**VOLUME III**

---

**HEADQUARTERS, DEPARTMENT OF THE ARMY**

**14 APRIL 1986**

TECHNICAL MANUAL  
No. 5-4210-222-14&P-3

HEADQUARTERS  
DEPARTMENT OF THE ARMY  
WASHINGTON, D.C., 14 April 1986

Operator's, Organizational, Direct Support,  
and General Support Maintenance Manual  
(Including Repair Parts and Special Tools List)

for

TRUCK, FIREFIGHTING, DRY CHEMICAL AFFF  
NSN 4210-00-484-5729

This manual consists of 3 volumes.

Each volume has its own table of contents. The index found in Volume I pertains only to Volume I.

VOLUME I is the Illustrated Parts Breakdown for the entire truck.

VOLUME II contains the Operation, Maintenance, and Repair Manual for:  
ENGINE, TRANSMISSION, CHASSIS, CAB and RELATED ITEMS

VOLUME III contains the Operation, Maintenance and Repair Manual for:  
TWIN AGENT UNIT, INVERTER, HYDRAULIC RESCUE TOOL (Jaws of Life),  
POWER UNIT, RESCUE SAW 10 TON HYDRAULIC RESCUE KIT,  
ELECTRONIC SIREN

NOTE: Throughout these manuals, information has been deleted which is not pertinent.

#### **REPORTING ERRORS AND RECOMMENDING IMPROVEMENTS**

You can help improve this manual. If you find any mistake or if you know of a way to improve the procedures, please let us know. Mail your letter, DA Form 2028 (Recommended Changes to Publications and Blank Forms), or DA Form 2028-2 located in the back of this manual directly to: Commander, U.S. Army Troop Support Command, ATTN: AMSTR-MCTS, 4300 Goodfellow Boulevard, St. Louis, MO 63120-1798. A reply will be furnished directly to you.

#### **REPORTING EQUIPMENT IMPROVEMENT RECOMIENDATIONS (EIR)**

If your fire truck needs improvement, let us know. Send us an EIR. You, the user, are the only one who can tell us what you don't like about your equipment. Let us know why you don't like the design. Put it on an SF 368 (Quality Deficiency Report). Mail it to us at Commander, U.S. Army Troop Support Command, ATTN: AMSTR-QX, 4300 Goodfellow Boulevard, St. Louis, MO 63120-1798. A reply will be furnished to you.

**OPERATION, MAINTENANCE AND REPAIR MANUAL**

VOLUME III

**TABLE OF CONTENTS**

<u>SECTION</u>	<u>PAGE</u>
<u>ROCKWOOD INSTRUCTION AND SERVICE MANUAL</u>	
<u>TWIN AGENT 1500/250 DRY CHEMICAL/AFFF—UNIT</u> .....	4001
SECTION I TWIN AGENT UNIT (DRY CHEMICAL AND AFFF) .....	4002
Stand-By Mode .....	4003
Operation Instructions, Hose Reel.....	4005
Operation Instructions, Turret.....	4005
System Purging Operation, Dry Chemical.....	4006
System Purging Operation, AFFF .....	4006
Bleeding Operation, Dry Chemical .....	4008
Bleeding Operation, AFFF .....	4008
Filling Instructions, Dry Chemical .....	4009
Filling Instructions, AFFF .....	4009
Parts List and Schematic.....	4010
Dry Chemical Unit.....	4011
Scope .....	4011
Introduction .....	4011
Principle of Operation .....	4011
System Components.....	4012
Maintenance .....	4015
Troubleshooting .....	4015
Spare Parts .....	4016
AFFF Unit .....	4017
Scope .....	4017
Introduction .....	4017
Principle of Operation .....	4017
System Components.....	4017
Maintenance .....	4020
Troubleshooting .....	4020
Spare Parts .....	4021
SECTION II DATA SHEETS FOR COMPONENTS SUPPLIED .....	4023
1+ Inch M Series Ball Valve with Air Actuator .....	4023
Hannay Hose Reel.....	4029
SECTION III DISCHARGE DEVICES .....	4034
Twin Agent Handline Index.....	4036
Scope.....	4037
Nozzle Data .....	4037
Description.....	4037
Operating Instructions .....	4038
Maintenance .....	4038
Spare Parts.....	4038

**OPERATION, MAINTENANCE AND REPAIR MANUAL**

VOLUME III

**TABLE OF CONTENTS**

<u>SECTION</u>	<u>PAGE</u>
Remote Manual Twin Agent Turret Foam/ Dry Powder Index .....	4043
Scope .....	4044
Introduction .....	4044
Figures .....	4044
Operating Instructions .....	4045
Maintenance .....	4045
Spare Parts.....	4046
 DYNAMOTE "A-30" INVERTER OPERATING, INSTALLATION AND SERVICE MANUAL .....	 4062
 SECTION I DYNAMOTE LIMITED WARRANTY .....	 4063
 SECTION II GENERAL INFORMATION .....	 4065
Introduction and Principle of Operation .....	4065
Specifications .....	4066
Product Configuration.....	4066
 SECTION III INSTALLATION INSTRUCTIONS.....	 4068
Instructions .....	4068
Route Harness to Alternator .....	4069
Install Automatic Throttle .....	4071
Attach Harness to Alternator .....	4071
Checkout of Harness Installation.....	4074
Checkout Inverter Operation .....	4082
 SECTION IV SERVICE AND TROUBLESHOOTING INSTRUCTIONS .....	 4084
General Information.....	4084
Inverter Removal from Vehicle for Servicing .....	4084
Troubleshooting Guide .....	4085
Inverter Parts List .....	4097



**OPERATION, MAINTENANCE AND REPAIR MANUAL**

VOLUME III

**TABLE OF CONTENTS**

<u>SECTION</u>	<u>PAGE</u>
4 CYCLE HURST POWER UNIT INSTRUCTION MANUAL .....	4113
Parts List .....	4115
Assembling Instructions.....	4116
Operating Instructions .....	4120
Troubleshooting Instructions .....	4126
HURST JAWS OF LIFE MODEL 32b INSTRUCTION MANUAL.....	4130
Parts List .....	4132
Assembling Instructions.....	4133
Troubleshooting Instructions .....	4137
Maintenance .....	4137
Operating Instructions .....	4139
Cutting Instructions.....	4143
PARTNER K-1200 RESCUE SAW SERVICE MANUAL.....	4148
Safety Precautions.....	4149
Fitting Cutter Arm .....	4151
Turning Cutter Arm .....	4152
Replacing Belt.....	4153
Fuel Mixture .....	4153
Fuel Tank.....	4153
Controls .....	4153
Starter Unit .....	4154
Air Filter .....	4154
Carburetor .....	4154
Maintenance .....	4155
Technical Data.....	4156
PARTNER K-1200 RESCUE SAW OPERATOR'S MANUAL.....	4157
Table of Contents .....	4158
Forward .....	4159
Parts Description .....	4161
Pre-Checkout.....	4163
Cutter Wheels.....	4166
Diamond Blades .....	4167
Carbide-Tipped Blades .....	4169
Operation.....	4170
Safety Regulations.....	4176
10 TON HYDRAULIC PORTO-POWER RESCUE KIT OPERATING INSTRUCTIONS .....	4178
Troubleshooting Chart Solution.....	4180
Troubleshooting Chart.....	4180

**OPERATION, MAINTENANCE AND REPAIR MANUAL**

VOLUME III

**TABLE OF CONTENTS**

<u>SECTION</u>	<u>PAGE</u>
10 TON HYDRAULIC PORTO-POWER RESCUE KIT OPERATING INSTRUCTIONS - Continued	
Function .....	4181
Operating Instructions .....	4181
Maintenance .....	4182
Inspection .....	4182
SIGNAL MODEL PA300* ELECTRONIC SIREN INSTALLATION AND SERVICE INSTRUCTIONS .....	4186
Section I     General Description.....	4187
Section II    Specifications .....	4188
Section III   Installation .....	4189
Section IV    Operation.....	4193
Section V     Circuit Description .....	4195
Section VI    Service and Maintenance .....	4198

OPERATION, MAINTENANCE AND REPAIR MANUAL

VOLUME III

LIST OF ILLUSTRATIONS

<u>TITLE</u>	<u>IDENTIFICATION/ ILLUSTRATION</u>	<u>PAGE(S)</u>
<u>ROCKWOOD INSTRUCTION AND SERVICE MANUAL</u>		
<u>TWIN AGENT 1500/250 DRY CHEMICAL/ AFFF UNIT</u>		
Rockwood Twin Agent RTA 1500/250 System Schematic.....	510-2120-1	4010
1" M Series Ball Valve with Air Actuator.....	C-509-0663	4023
Hannay Hose Reel .....	ISO-72	4029
Installation Instructions.....	6185-1	4032
Wiring Diagram (Hose Reel) .....	6185-1	4033
Dual Agent Handline Foam/Dry Powder.....	Figure I	4039
Turret Remote Manual Twin Agent .....	Figure I	4047
Turret Remote Manual Twin Agent Assembly .....	Figure 1A	4049
Remote Manual Turret .....	Figure II	4051
Shaper - AFFF.....	Figure III	4054
Dry Chemical Nozzle.....	Figure IV	4056
Twin Agent 1500/250 Dual Agent System.....	510-2120	4058 to 4061
 <u>INVERTER, DYNAMOTE A-30</u>		
Inverter Off .....	2.0.2A	4065
Inverter On .....	2.0.2B	4065
A30 Dimensions .....	2.2.5B	4067
Mounting Configuration .....	2.2.6A	4067
Belt Alignment .....	3.3.2A and 3.3.2B	4070
High Amperage By-Pass Installation.....	3.5.1A	4071
Diagram of Leece-Neville 4000AA Series Alternator.....	3.5.4C	4073
SCR Checkout Procedure .....	----	4091
Diode Checkout Procedure and Readings .....	4.3.10A	4095
A30-70D Unit Wire Diagrams .....	2075	4101
A30-70D Unit Schematic .....	2075-1	4102
 <u>HURST 4 CYCLE POWER UNIT</u>		
4 Cycle Schematic.....	----	4114
 <u>HURST JAWS OF LIFE</u>		
Rescue Tool Schematic .....	----	4131
Accessories .....	----	4132

OPERATION, MAINTENANCE AND REPAIR MANUAL

VOLUME III

LIST OF ILLUSTRATIONS

<u>TITLE</u>	<u>IDENTIFICATION/ ILLUSTRATION</u>	<u>PAGE(S)</u>
<u>PARTNER K-1200 RESCUE SAW</u>		
Rescue Saw Schematic .....	----	4150, 4160
Fitting the Cutter Arm .....	----	4151
Turning the Cutter Arm.....	----	4152
Tools .....	----	4155
Safety Regulations .....	----	4176
<u>10 TON HYDRAULIC PORTO-POWER RESCUE KIT</u>		
Spongy Effect .....	Figure 1	4180
Ram Won't Retract .....	Figure 2	4180
Clamps .....	Figure 3	4182
<u>SIGNAL MODEL PA300* ELECTRONIC SIREN</u>		
Model PA300 Electronic Siren .....	Figure 1-1	4187
Rear View of PA300 .....	Figure 3-2	4190
Control Cable Wiring Diagram .....	Figure 3-3	4190
Horn Ring Connections .....	Figure 3-4	4190
Press and Hold Modification .....	Figure 3-5	4192
Relative PA Loudness Adjustment.....	Figure 3-6	4192
Model PA300 Front View .....	Figure 4-1	4193
Functional Block Diagram .....	Figure 5-1	4195
Chassis Removed .....	Figure 6-1	4199
Internal View .....	Figure 6-2	4199
Component Location Diagram.....	Figure 6-3	4200
Schematic Diagram .....	Figure 6-4	4201

OPERATION, MAINTENANCE AND REPAIR MANUAL

VOLUME III

LIST OF TABLES

<u>TITLE</u>	<u>IDENTIFICATION/ ILLUSTRATION</u>	<u>PAGE(S)</u>
ROCKWOOD TWIN AGENT 1500/250 DRY CHEMICAL/AFFF UNIT		
Pressure vs Temperature Chart .....	Table 1	4022
DYNAMOTE INVERTER		
Harness and Alternator .....	3.6.2A	4081

ROCKWOOD TWIN AGENT  
1500/250 DRY CHEMICAL/AFFF UNIT

ROCKWOOD INSTRUCTIONS  
LOG NO. RIM 1554

KOVATCH CORPORATION  
500-600 WEST CATAWISSA ST.  
NESQUEHONING, PA 18240  
SALES ORDER C100360

MARCH, 1985

REVISED:  
JULY, 1985

**4001**

ROCKWOOD SYSTEMS CORPORATION  
640 East Main Street  
Lancaster, Texas 75146

SECTION I  
**TWIN AGENT UNIT**

**4002**

OPERATIONAL PROCEDURES

**(SEE SCHEMATIC ON PAGE 4010 FOR ITEM NUMBERS)**

**STAND-BY MODE:**

**DRY CHEMICAL**

1. The Dry Chemical Tank shall be full and Fill Cap securely installed. Nitrogen cylinders shall be full.
2. Turret Control Switch; OFF
3. Charging Switches; OFF
4. Nozzle Discharge Valve - 2B; CLOSED
5. Hose Reel Valve - 9B; CLOSED
6. Nitrogen By - Pass Valve - 13C; CLOSED
7. Nitrogen Bleed Valve - 13B; CLOSED
8. Master Nitrogen Valve - 12B; OPEN
9. Master Discharge Valve - 6B; CLOSED
10. M. D. V. Actuator Bleed Valve - 21B; CLOSED
11. Turret Discharge Valve - 109; CLOSED
12. Quick Opening Valves - 81A; SET

**AFFF FOAM SYSTEM**

1. The AFFF Tank shall be full and Fill Cap securely installed. Nitrogen cylinders shall be full.
2. Turret Control Switch; OFF
3. Charging Switches; OFF
4. Nozzle Discharge Valve - 2A; CLOSED
5. Hose Reel Valve - 9A; CLOSED
6. Nitrogen By-Pass Valve - 13A; CLOSED
7. Master Nitrogen Valve - 12A; OPEN
8. Master Discharge Valve - 6A; CLOSED
9. M. D. V. Actuator Bleed Valve - 21A; CLOSED

**4003**



**(SEE SCHEMATIC ON PAGE 4010 FOR ITEM NUMBERS)**

- |                                    |        |
|------------------------------------|--------|
| 10. Drain Valve - 7B;              | CLOSED |
| 11. Turret Discharge Valve - 108;  | CLOSED |
| 12. Quick Opening Valves - 81A;    | SET    |
| 13. Temperature Relief Valve - 71; | CLOSED |

(SEE SCHEMATIC ON PAGE 4010 FOR ITEM NUMBERS)

**OPERATING INSTRUCTIONS**

**HOSE REEL**

**WARNING**

The discharge of large amounts of dry chemical may create hazards to personnel such as reduced visibility and temporary breathing difficulty.

1. Activate system by placing desired agent(s) "CHARGING SWITCH" in "ON" position. (Press dashboard actuator if activating from the cab.)
2. Place desired agent(s) hose reel valve 9A/9B in "OPEN" position.
3. Unlock brake on hose reel.
4. Remove nozzle.
5. Unwind hose to desired length.
6. Place desired agent(s) nozzle discharge valve 2A/2B in "OPEN" position; operate as required.

NOTE: The Dry Chemical System and AFFF Foam System-can be used simultaneously or independently.

**TURRET**

**WARNING**

The discharge of large amounts of dry chemical may create hazards to personnel such as reduced visibility and temporary breathing difficulty.

1. Activate system by placing desired agent(s) "CHARGING SWITCH" in "ON" position. (Press dashboard actuator if activating from cab.)
2. Release turret handle locking devices
3. Select desired spray pattern.
4. Activate turret by placing selected agent switch in "ON" position. Discharge may be stopped at any time by placing switch in "OFF" position. To resume discharge, place switch in "ON" position.

NOTE: The Dry Chemical System and AFFF Foam System can be used simultaneously or independently.

(SEE SCHEMATIC ON PAGE 4010 FOR ITEM NUMBERS)

**SYSTEM PURGING OPERATION**

**DRY CHEMICAL**



The discharge of large amounts of dry chemical may create hazards to personnel such as reduced visibility and temporary breathing difficulty.

1. Place "CHARGING SWITCH" in "OFF" position.
2. Shut master nitrogen valve 12B.
3. Slowly open valve 218 and vent tank pressure until relief valve 88A is reseated and valve 6B can be shut; then shut valve 21B.
4. Shut master discharge valve 6B.
5. Shut bleed valve 13B.
6. Place "CHARGING SWITCH" in "ON" position.
7. Slowly open nitrogen by-pass valve 13C.
8. Cycle nozzle discharge valve 2B. Open and close. Shut nozzle discharge valve when purging is complete.
9. Place "CHARGING SWITCH" in "OFF" position and reset the quick opening valves 81A.
10. Shut nitrogen by-pass valve 13C.
11. Open master nitrogen valve 12B.

**AFFF FOAM SYSTEM**

1. Place "CHARGING SWITCH" in "OFF" position.
2. Shut master nitrogen valve 12A.
3. Slowly open valve 21A and vent tank pressure until relief valve 88B is reseated and valve 6A can be shut; then shut valve 21A.
4. Shut master discharge valve 6A.
5. Shut bleed valve 13A.
6. Place "CHARGING SWITCH" in "ON" position.
7. Slowly open nitrogen by-pass valve 13A.
8. Cycle nozzle discharge valve 2A. Open and close. Shut nozzle discharge valve when purging is complete.

**(SEE SCHEMATIC ON PAGE 4010 FOR ITEM NUMBERS)**

9. Place "CHARGING SWITCH" in "OFF" position and re-set the Quick Opening Valves - 81A.
10. Shut Nitrogen By-Pass Valve - 13A.
11. Open Master Nitrogen Valve - 12A.

## BLEEDING OPERATION

**(SEE SCHEMATIC ON PAGE 4010 FOR ITEM NUMBERS)**

### **DPY CHEMICAL**

1. Place "CHARGING SWITCH" in "OFF" position. Open Valve - 81C to vent actuation line, then re-set the Quick Release Valve for Dry Chemical Nitrogen Cylinders.
2. Slowly open Valve - 21B and vent tank pressure until Relief Valve - 88A is re-seated and Valve - 6B can be shut; then shut Valve - 21B.
3. Shut Dry Chemical Master Discharge Valve - 6B.
4. Shut Nitrogen Purge Valve - 13C.
5. Open Hose Reel Auxiliary Discharge Valve - 9B.
6. Slowly open Bleed Valve - 13B.
7. Open Nozzle Discharge Valve - 2B and vent off excess nitrogen pressure. Then shut discharge valve.
8. Shut Bleed Valve - 13B.

### **AFFF FOAM SYSTEM**

1. Place "CHARGING SWITCH" in "OFF" position. Open Valve - 81C to vent actuation line, then re-set the Quick Release Valve for foam nitrogen cylinders.
2. Slowly open Valve - 21A and vent tank pressure until Relief Valve - 88B is re-seated and Valve - 6A can be shut; then close Valve - 21A.
3. Shut AFFF Master Discharge Valve - 6A.
4. Open Hose Reel (Auxiliary Discharge) Valve - 9A.
5. Slowly open Bleed Valve - 13A.
6. Open Nozzle Discharge Valve - 2A and vent off excess nitrogen pressure. Then shut discharge valve.
7. Shut Bleed Valve - 13A.

**4008**

**-6-**

## FILLING INSTRUCTIONS

### DRY CHEMICAL

1. Vent the system per enclosed "Bleeding Operation" instructions.
2. Shut master nitrogen valve 12B.
3. Slowly remove fill plug from the top of the tank.

#### **WARNING**

Be sure all pressure is expelled from the dry chemical tank 1B before removing plug. If pressure venting sound is audible when cap is turned, "STOP" immediately and repeat steps 1, 2, and 3.

#### **WARNING**

Avoid breathing dry chemical dust while filling tank.

4. Fill dry chemical tank 1B to the top with Purple-K-Powder. Do not rod or tamp dry chemical into the tank.
5. Replace fill plug on tank and tighten firmly.
6. Open master nitrogen valve 12B.
7. Check nitrogen pressure. If pressure is below 1800 psi at 70° F., replace cylinder.

### AFFF FOAM SYSTEM

1. Vent the system per enclosed "Bleeding Operation" instructions.
2. Shut master nitrogen valve 12A.
3. Slowly remove fill plug from the top of the tank.

#### **CAUTION**

Be sure all pressure is expelled from the AFFF tank 1A before removing plug. If pressure venting sound is audible when cap is turned, "STOP" immediately and repeat steps 1, 2, and 3.

4. Fill AFFF tank 1A to the top with water and AFFF as specified on the refill table located at the rear of the skid unit.
5. Replace fill plug on tank and tighten firmly.
6. Open master nitrogen valve 12A.
7. Check nitrogen pressure. If pressure is below 1800 psi at 70° F., replace cylinder.

## DRY CHEMICAL UNIT

### 1.0 SCOPE

This manual defines the following for Rockwood's Self Contained Dry Chemical Unit :

	PAGE
a) Principle of operation .....	4011
b) System description .....	4012
c) Operating Instructions .....	4005
d) Maintenance procedures .....	4015
e) Trouble shooting.....	4015
f) Recommended spare parts .....	4016

### 2.0 INTRODUCTION

#### 2.1 PURPOSE:

Dry Chemical Fire Extinguishing Systems are used throughout the fire protection industry on class B and C fires for rapid extinguishment and knock down capabilities.

Typical uses for Dry Chemical Extinguishing Systems consist of:

- A) Offshore platforms
- B) Tankers
- C) Bulk fuel handling terminals
- D) Heavy industrial marine, petroleum, chemical and petrochemical operations
- E) Pipe lines
- F) Crash truck and quick response vehicles
- G) Wherever fuel and chemical spills create a potential hazard.

#### 2.2 PRINCIPLE OF OPERATION:

The Dry Chemical Unit utilizes dry nitrogen in a pressurized cylinder as the propellant for the extinguishing agent and therefore requires no other power source.

Nitrogen is released from the cylinder via the bottle stop or quick releasing device. The pressure is then reduced by going through a special high capacity regulator prior to entering the dry chemical tank where the dry chemical is fluidized, aggitated and pressurized. Dry chemical is then propelled through a handline or fixed discharge devices depending upon the application. Flow rates are controlled by the various types of discharge devices.

### 3.0 SYSTEM COMPONENTS

The item numbers below refer to the system schematic of Figure 510-2120-1 Page 4010

#### 1B. A.S.M.E. DRY CHEMICAL TANK

The Rockwood Dry Chemical Tank is designed, constructed and inspected in accordance with Section VIII, Rules For Construction of Pressure Vessels, Division 1 of the ASME Code. All tanks are designed for a working pressure of 250 PSI.

The Dry Chemical Tank is a spherical steel tank equipped with openings for nitrogen gas input, a combination nitrogen bleed purge and safety relief, dry chemical discharge, dry chemical fill and dry chemical clean out.

The Dry Chemical Tank has a four inch diameter fill opening and a threaded self venting pressure plug. The plug is designed so that there are at least four threads engaged when the plug vent is exposed. This protects the operator from injury should any residual pressure remain in the tank prior to recharging.

The Tanks have a welded on external skirt support to facilitate mounting.

The Dry Chemical Tank must contain a sufficient quantity of dry chemical for the required discharge time of the system, depending upon the application of the system.

#### 2A, 2B DISCHARGE DEVICE

Rockwood's Dry Chemical Systems can be used on either portable or stationary systems with either fixed or manual discharge devices.

Some examples of Rockwood's Dry Chemical Discharge Devices consist of: Fixed nozzles, hose reels with twin agent handlines, or Dry Chemical handlines, twin agent turrets and dry chemical turrets. Any one or combination of these devices are compatible with Rockwood's Dry Chemical System.

#### 3B. CHECK VALVE

A Check valve is installed downstream of the nitrogen regulator to prevent backflow of dry chemical from the tank to the regulator. A high back pressure could occur if a discharge outlet were shut off quickly.



4B. NITROGEN REGULATOR

Rockwood's Dry Chemical System utilizes a special high flow capacity regulator to achieve the constant discharge rate required. The Regulator reduces the high nitrogen cylinder pressure to 230 psig. The Regulator incorporates a built in safety valve set to limit the secondary pressure to 400 psig. High and low pressure gage connections are also provided.

6B. MASTER DISCHARGE VALVE

A Discharge Valve is located in the discharge line of the Dry Chemical Tank. This valve is normally open but shall be shut when the discharge lines are purged with nitrogen or when bleeding off the residual nitrogen pressure in the Dry Chemical Tank after full or partial discharge. It is recommended that the discharge valve be safety wired in the open position after the lines have been cleared and the unit is placed in standby condition.

10B. PRESSURE RELIEF VALVE

The Pressure Relief Valve provides the tank with protection against over pressure conditions in the event of a sudden shutdown of one or more of the discharge devices or failure of the nitrogen regulator. The Relief Valve is set at 275 psi.

11C, D NITROGEN CYLINDER(S)  
&E

The Nitrogen Cylinder(s) provide the system with the required supply of high pressure nitrogen to completely discharge all the chemical agents and clean out all lines after discharge. The cylinders contain dry nitrogen at approximately 2,400 psig at 21.10C (700F). Bottle quantity and capacity are based upon required system duration and flow rate. Each bottle has a hand wheel operated bottle stop (or a quick release device if desired item 16B) and a safety valve set at approximately 3,000 psi.

12B. MASTER NITROGEN SUPPLY VALVE

The Master Nitrogen Supply Valve isolates the dry chemical tank from the nitrogen supply when filling or cleaning out the tank. This valve is also closed to isolate the tank when purging the system after discharge to clean out the piping and hose lines.

13C. NITROGEN BY-PASS VALVE

A By-Pass (purging) Valve is located in the lines of the nitrogen manifold system to enable the operator to by-pass the dry chemical tank with pressurized nitrogen when clearing (purging) the discharge line after use or checking the discharge lines during maintenance.

13 B BLEED VALVE

A Bleed Valve is located in the lines of the nitrogen manifold system to enable the operator to depressurize the tank and facilitate purging the discharge line after use.

14B. HIGH PRESSURE GAGE

A High Pressure Gage is located on the inlet side of the nitrogen regulator to indicate cylinder supply pressure. The gage has a range of 0 3000 psi.

15B. LOW PRESSURE GAGE

A Low Pressure Gage is located on the outlet side of the nitrogen regulator to indicate system pressure. The gage has a range of 0 - 400 psi with normal operating pressure equal to 230 psi at 700F.

#### 4.0 MAINTENANCE

A periodic check of the following should be made every thirty days.

1. Perform stand-by mode check, page 4003, to ensure valves are in proper position.
2. Check nitrogen cylinder pressure per filling instructions, steps 2 and 6, page 4009. Replace cylinder if pressure is below 1800 psi at 70° F., as read on gauge 14B (refer to table I). Nitrogen to be per FED-SPEC-BB-N-411, type I, Class I.
3. Ensure that discharge device works freely. Discharge device (2A, 2B, etc.) control valve should be left shut when check is complete.
4. Make certain that tank is full.
5. Check gauges for cracked or broken glass.
6. The dry chemical system is virtually maintenance free. Use touchup paint and rust preventatives as required. If the unit has been worked on, check valve position for proper ready standby configuration per stand-by mode, page 4003.

#### 5.0 TROUBLESHOOTING

The information listed below provides some direction for troubleshooting difficulties that may be encountered with dry chemical systems.

TROUBLE	PROBABLE CAUSE	REMEDY
<u>Dry Chemical System</u> High pressure gauge shows loss of pressure	Low temperature	Check high pressure gauge reading against data in table 1. Check for leaks at cylinder valve.
	Cylinder low/empty	Replace cylinder.
Low pressure gauge reads other than 230 psi	Defective regulator	Replace regulator.
	Improper setting	Consult factory.

TROUBLE	PROBABLE CAUSE	REMEDY
Decreased flow of dry chemical	Plugged pick-up tube or packed hose resulting from incomplete clean-out	Clean out line as per instruction in dry chemical system purging operations, page 4006.
	Defective regulator	Replace regulator
	Discharge valve(s) partially closed	Turn valve to wide open position.
	Master nitrogen valve partially closed	Turn valve to wide open position
	Nitrogen by-pass (purge) valve partially open	Turn valve to full closed position
	Nitrogen bleed valve partially open	Turn valve to full closed position

CAUTION:

BEFORE PRESSURIZING, DEPRESSURIZING OR SERVICING DRY CHEMICAL UNIT, READ OPERATIONS MANUAL TO ASSURE STRICT ACCORDANCE WITH INSTRUCTIONS.

## 6.0 SPARE PARTS

The following items are the recommended list of spare parts:

<u>ITEM</u>	<u>PART NUMBER</u>	<u>DESCRIPTION</u>	<u>QTY</u>
1	509-0327	Repair Kit: ½" M802 B.V.	1
2	509-0329	Repair Kit: 1" M802 B.V.	1
3	509-0331	Repair Kit: 1s" M802 B.V.	1
4	6129-2	Nitrogen Regulator	1
5	6156-15	High Pressure Gage	1
6	6156-12	Low Pressure Gage	1
7	110-3736-1	Gasket	1

AFFF UNIT

1.0 SCOPE

This manual defines the following for Rockwood’s Self Contained AFFF Units:

	PAGE
a) Principle of Operation .....	4017
b) System Description.....	4017
c) Operating Instructions .....	4017
d) Maintenance Procedures.....	4020
e) Trouble Shooting .....	4020
f) Recommended Spare Parts .....	4021

2.0 INTRODUCTION

2.1 PURPOSE:

AFFF Fire Extinguishing Systems are used throughout the fire protection industry on class B fires and spills. By securing the hazard with an expanded AFFF solution, the flammable vapors are suppressed, reducing the possibility of ignition. AFFF systems are designed for quick knock down of the fire, vapor suppression and blowback resistance.

Typical uses for AFFF Extinguishing Systems consist of:

- A) Offshore platforms
- B) Tankers
- C) Bulk Fuel Handling Terminals
- D) Heavy Industrial Marine, Petroleum, Chemical and Petrochemical Operations.
- E) Pipe Lines
- F) Crash Truck and Quick Response Vehicles
- G) Wherever Fuel and Chemical Spills Create a Potential Hazard.

2.2 PRINCIPLE OF OPERATION:

The AFFF Unit utilizes dry nitrogen in a pressurized’ cylinder as the propellant for the extinguishing agent and therefore requires no other power source.

Nitrogen is released from the cylinder via the bottle stop or quick releasing device. The pressure is then reduced by going through a special high capacity regulator prior to entering the AFFF tank where the AFFF premix solution is pressurized. AFFF is then propelled through a handline or fixed discharge devices depending upon the application. Flow rates are controlled by the various types of discharge.

3.0 SYSTEM COMPONENTS

The item numbers below refer to the system schematic of Fig. 510-2120-1 Page 4010.

1A. A.S.M.E. AFFF TANK

The Rockwood AFFF Tank is designed, constructed and inspected in accordance with Section III, Rules for Construction of Pressure vessels, Division 1 of the ASME Code. All tanks are designed for a working pressure of 250 PSI.

The AFFF Tank is equipped with openings for nitrogen gas input, a combination, nitrogen bleed purge and safety relief, AFFF discharge, AFFF fill and AFFF drain.

The Tanks have a welded on external skirt support to facilitate mounting.

The AFFF Tank must contain a sufficient quantity of Foam Solution for the required discharge time of the system.

2A, 2B etc. DISCHARGE DEVICE(S)

Rockwood's AFFF Systems can be used on either portable or stationary systems with either fixed or manual discharge devices.

Some examples of Rockwood's AFFF Discharge Devices consist of: Fixed nozzles, hose reels with twin agent handlines, or AFFF handlines, twin agent turrets and foam turrets. Any one or combination of these devices are compatible with Rockwood's AFFF System.

3A. CHECK VALVE

A Check valve is installed downstream of the nitrogen regulator to prevent backflow of AFFF solution from the tank to the regulator. A high back pressure could occur if a discharge outlet were shut off quickly.

4A. NITROGEN REGULATOR

Rockwood's AFFF System utilizes a special high flow capacity regulator to achieve the constant discharge rate required. The Regulator reduces the high nitrogen cylinder pressure to 230 psig. The Regulator incorporates a built in safety valve set to limit the secondary pressure to 400 psig. High and low pressure wage connections are also provided.

6A. MASTER DISCHARGE SALVE

A Discharge Valve is located in the discharge line of the AFFF Tank. This valve is normally open but shall be shut when the discharge lines are purged with nitrogen or when bleeding off the residual nitrogen pressure in the AFFF Tank after full or partial discharge. It is recommended that the discharge valve be safety wired in the open position after the lines have been cleared and the unit is placed in standby condition.

7B. FOAM SOLUTION DRAIN VALVE

The Foam Solution Drain Valve is required for maintenance of the tank.

8. FILL CUP

The Fill Cup is used for gravity filling of tile foam solution AFFF Tank.

9A, 9B AUXILIARY DISCHARGE VALVE(S)

Auxiliary Discharge Valve(s) are provided to allow isolation of one or more systems while maintaining the remaining discharge devices in an operable condition. They can also be used to minimize nitrogen loss when purging the system after using only one discharge device. These valves are only provided if there are two or more separate discharge devices/zones.

10A. PRESSURE RELIEF VALVE

The Pressure Relief Valve provides the tank with protection against over pressure conditions in the event of a sudden shutdown of one or more of the discharge devices or failure of the nitrogen regulator. The Relief Valve is set at 275 psi.

11A. NITROGEN CYLINDER(S)

The Nitrogen Cylinder(s) provide the system with the required supply of high pressure nitrogen to completely discharge all the chemical agents and clean out all lines after discharge. The cylinders contain dry nitrogen at approximately 2,400 psig at 21.1°C (70°F). Bottle quantity and capacity are based upon required system duration and flow rate. Each bottle has a hand wheel operated bottle stop (or a quick release device if desired item 16A) and a safety valve set at approximately 3,000 psi.

12A. MASTER NITROGEN SUPPLY VALVE

The Master Nitrogen Supply Valve isolates the AFFF tank from the nitrogen supply when filling or draining the tank. This valve is also closed to isolate the tank when purging the system after discharge to clean out the piping and hose lines.

13A. NITROGEN BY-PASS VALVE

A By-Pass (purging) valve is located in the lines of the nitrogen manifold system to enable the operator to by-pass the AFFF tank with nitrogen when clearing (purging) the discharge line after use or checking the discharge lines during maintenance.

14A. HIGH PRESSURE GAGE

A High Pressure Gage is located on the inlet side of the nitrogen regulator to indicate cylinder supply pressure. The gage has a range of 0 - 3000 psi.

15A. LOW PRESSURE GAGE

A Low Pressure Gage is located on the outlet side of the nitrogen regulator to indicate system pressure. The gage has a range of 0 - 400 psi with normal operating pressure equal to 230 psi at 70°F.

#### 4.0 MAINTENANCE

A periodic check of the following should be made every thirty days.

1. Perform stand-by mode check, page 4003, to ensure valves are in proper position.
2. Check nitrogen cylinder pressure per filling instructions, steps 2 and 6, page 4009. Replace cylinder if pressure is below 1800 psi at 700 F., as read on gauge 14A (refer to table I.) Nitrogen to be per FED-SPEC-BB-N-411, type I, Class I.
3. Ensure that discharge device works freely. Discharge device (2A, 2B, etc.) control valve should be left shut when check is complete.
4. Make certain that tank is full.
5. Check gauges for cracked or broken glass.
6. The AFFF system is virtually maintenance free. Use touch-up paint and rust preventatives as required. If the unit has been worked on, check valve position for proper ready stand-by configuration per stand-by mode, page 4003.
7. Shut master discharge valve 6A. Remove, clean and reinstall strainer basket 5. Open 6A to place system back into normal stand-by condition.

#### 5.0 TROUBLESHOOTING

The information listed below provides some direction for troubleshooting difficulties that may be encountered with self contained AFFF systems.

TROUBLE	PROBABLE CAUSE	REMEDY
<u>AFFF System</u> High pressure gauge shows loss of pressure	Low temperature	Check high pressure gauge reading against data in table I. Check for leaks at cylinder valve.
	Cylinder low/empty	Replace cylinder.
Low pressure gauge reads other than 230 psi	Defective regulator	Replace regulator.
	Improper setting	Consult factory.



TROUBLE	PROBABLE CAUSE	REMEDY'
Decreased flow of AFFF solution.	Plugged or packed hose resulting from incomplete clean-out	Clean out line as per instruction in dry chemical system purging operations, page 4006.
	Defective regulator	Replace regulator
	Discharge valve(s) partially closed	Turn valve to wide open position.
	Nitrogen by-pass (purge) valve partially open	Turn valve to full closed position.
	Nitrogen bleed valve partially open.	Turn valve to full closed position
	Fill and/or drain valve partially open	Turn valve to full closed position.

CAUTION:

BEFORE PRESSURIZING, DEPRESSURIZING OR SERVICING AFFF UNIT, READ OPERATIONS MANUAL TO ASSURE STRICT ACCORDANCE WITH INSTRUCTIONS.

#### 6.0 SPARE PARTS

The following items are the recommended list of spare parts:

<u>ITEM</u>	<u>PART NUMBER</u>	<u>DESCRIPTION</u>	<u>QTY</u>
1	509-0327	Repair Kit: ½" M802 B.V.	1
2	509-0329	Repair Kit: 1" M802 B.V.	1
3	509-0332	Repair Kit: 2" M802 B.V.	1
4	6129-2	Nitrogen Regulator	1
5	6156-15	High Pressure Gage	1
6	6156-12	Low Pressure Gage	1

PRESSURE VS. TEMPERATURE CHART

TEMPERATURE		PRESSURE CORRECTIONS FOR GAGE READING (Base Point 220 psig at 21.1°C (70°F))
°C	°F	
* 43.0	(110)	Subtract 221 psig from gage reading
38.0	(100)	Subtract 166 psig from gage reading
32.2	( 90)	Subtract 111 psig from gage reading
26.7	( 80)	Subtract 55 psig from gage reading
21.2	( 70)	0
15.6	( 60)	Add 56 psig to gage reading
10.0	( 50)	Add 112 psig to gage reading
4.4	( 40)	Add 168 psig to gage reading
*** 1.1	( 30)	Add 224 psig to gage reading.
-6.7	( 20)	Add 280 psig to gage reading
-12.2	( 10)	Add 336 psig to gage reading
-17.8	( 0)	Add 392 psig to gage reading
-23.0	(-10)	Add 448 psig to gage reading
-29.0	(-20)	Add 504 psig to gage reading
**		

NOTES:

- \* For temperatures above 43.0°C (110F) subtract 56 psig more from gage reading for every 12.2°C (10°F)
- \*\* For temperatures below -29.0°C (-20°F) add 56 psig more to gage reading for every 12.2°C (100F)
- \*\*\* EXAMPLE: Pressure gage reads 1, 700 psig and outside temperature is 1.1°C (30°F). Actual nitrogen pressure is 1, 924psig, which is found by adding 224 psig to gage reading.

TABLE 1.

Rockwood Systems Corporation

90 Second Street  
 Portland, Maine 04105

510-2120-1

ITEM		QTY	PART NO.	PART NAME
ROCKWOOD TWIN AGENT MOD. RTA 1500, 250 510-2120-1				
1A	1	510-1941-3	250 Gal. AFFF Foam Tank	
1	2	510-1919-4	1500 LB. DRY CHEMICAL TANK	
2	1	510-1678-4	DUAL AGENT HANDLINE	
3A,B	2	5457-8	1" CHECK VALVE	
4A,B	2	6129-2	NITROGEN REGULATOR	
5				
6A,E	2	509-0663-4	1 1/2" BALL VALVE W/AIR ACTUATOR	
7B	1	M802-662080	1" BALL VALVE	
8				
9A,B	2	M802-662080	1" BALL VALVE	
10A,E	2	508-0116-10	PRESSURE RELIEF VALVE	
11A-E	5	510-1869-3	NITROGEN CYLINDER	
12A,B	2	M802-662080	1" BALL VALVE	
13A,B	3	M802-662040	1/2" BALL VALVE	
14A,B	2	6156-15	PRESSURE GAUGE	
15A,B	2	6156-12	PRESSURE GAUGE	
16				
17				
18				
19				
20				
21A,B	2	105-542020	1/2" BALL VALVE	
30	1	6185-1	HOSE REEL	
45	2	6366-1	REGULATOR W/PRESSURE GAUGE	
50	1	510-1772-3C	TWIN AGENT HOSE ASSY	
71	1	6452-1	TEMPERATURE RELIEF VALVE	
79A,B	2	6187-1	CAB ACTUATOR	
80			PART OF ITEM 11	
81			PART OF ITEM 11	
88A,B	2	508-0116-5	PRESSURE RELIEF VALVE	
108	1	509-0663-4	1 1/2" BALL VALVE W/AIR ACTUATOR	
109	1	509-0663-4	1 1/2" BALL VALVE W/AIR ACTUATOR	
DATE	REV.	PREPARED BY	APPROVED BY	PAGE OF

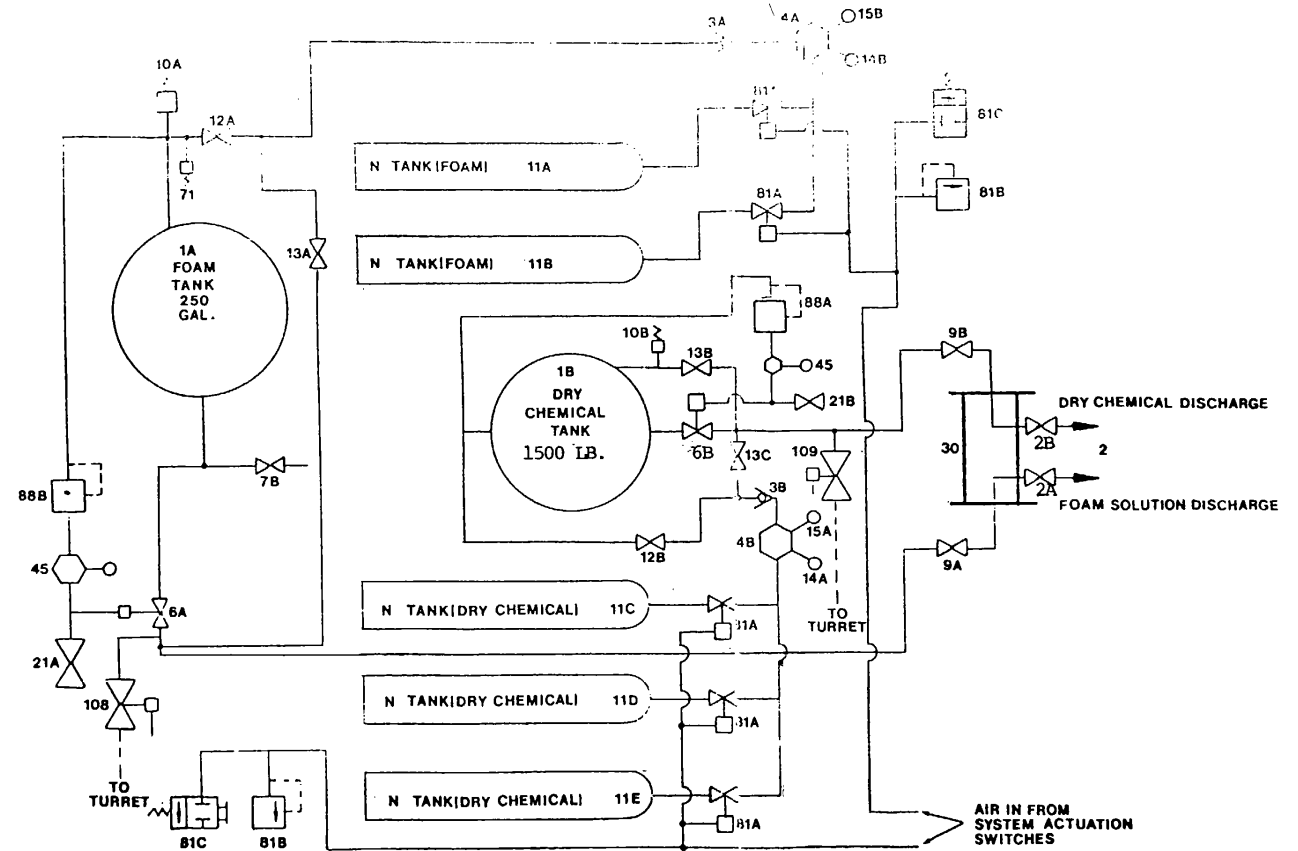

17-10

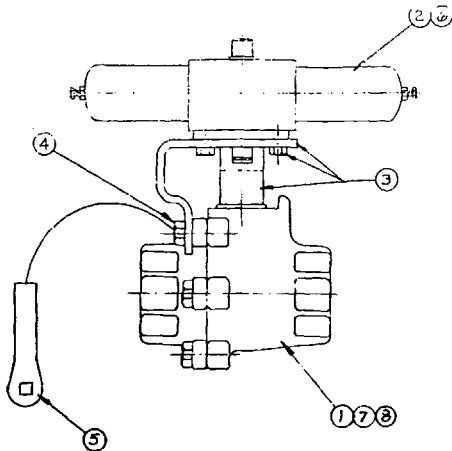

**NOTE:**  
 THE FOLLOWING PART NOS.  
 MAY BE USED WITH AIR, HYDRAULIC  
 FLUID OR WATER TO POWER  
 THE VALVE ACTUATORS

- 509-0663-1
- 509-0663-2
- 509-0663-3
- 509-0663-4

**ASSEMBLY PROCEDURE**

1. ORIENT ACTUATOR SHAFT TO CLOSED POSITION.
2. VERIFY THAT BALL VALVE IS CLOSED.
3. ASSEMBLE ACTUATOR, BRACKET, COUPLING & VALVE IN ANY CONVENIENT SEQUENCE.
4. ADJUST STOPS ON ACTUATOR FOR CORRECT TRAVEL TO GIVE FULL OPEN & TOTAL CLOSE OF VALVE.

REVISIONS		
REV.	BY	DESCRIPTION
1		ISSUED FROM 509-0663-1
2		ISSUED FROM 509-0663-2
3		ISSUED FROM 509-0663-3
4		ISSUED FROM 509-0663-4

QTY	REQD.	QTY	ISS.	QTY	RES.	PART OR IDENTIFYING I.D.	NUMBER, SIGNATURE OR DESCRIPTION	MATERIAL	SPECIFICATIONS OR REMARKS
1	-	-	-	8		M802-4321-0	1/2" M802 BALL VALVE		
-	1	-	-	7		M302-6331-0	1/2" M302 BALL VALVE		
1	1	1	-	6		6026-2	AIR ACTUATOR		
1	1	1	1	5		509-0663-2	HANDLE ASSY.		
2	2	2	2	4		152-0503-5	CAP SCREW - 9/16-18 X 1 1/4" LG.		
1	1	1	1	3		6083-1	ACTUATOR MOUNTING KIT		
-	-	-	-	2		6084-2	AIR ACTUATOR W/SOLENOID - 12 V.D.C. - NEMA 1		
-	-	-	-	1		M101-6611-2	1/2" M101 BALL VALVE		
-	2	-	2	2		152-0501-6	CAP SCREW 9/16-18 X 7/8 LG.		
-	1	-	1	-		109-0318	STOP PLATE		
-	1	-	1	-		109-0563	HANDLE		
-	1	-	1	-		167-12013	HANDLE LOCKWASHER		
-	1	-	1	-		167-08012	HANDLE NUT		

**LIST C.1 MATERIAL OR PARTS LIST**

UNLESS OTHERWISE SPECIFIED DIMENSIONS ARE IN INCHES FRACTIONS DECIMALS ANGLES 1 2 3 4 ALL SURFACES FINISH MATERIAL THIS DRAWING, INCLUDING ALL DIMENSIONS, SPECIFICATIONS, TOLERANCES, AND FINISHES, IS THE PROPERTY OF ROYALWOOD SYSTEMS CORPORATION. IT IS TO BE USED ONLY FOR THE PURPOSES INTENDED AND IS NOT TO BE REPRODUCED OR TRANSMITTED IN ANY FORM OR BY ANY MEANS, ELECTRONIC OR MECHANICAL, INCLUDING PHOTOCOPYING, RECORDING, OR BY ANY INFORMATION STORAGE AND RETRIEVAL SYSTEM.	DRAWN: R. Huff DATE: 10-20-81 CHECKED: J.S. DATE: 7/20/82 ENGR: J.S. DATE: 7/20/82 SCALE: NONE	ROYALWOOD SYSTEMS CORPORATION 80 Second Street South Portland, Maine 04106 <b>4023</b> NEXT ASSEMBLY TO MATE: C 509-0663-1
--	--	---

**SECTION II. 4023**



**RAYMOND  
CONTROL  
SYSTEMS**  
A HUNTSWICK COMPANY

**TYPE AA  
FIELD INSTALLATION INSTRUCTIONS  
PNEUPOWR ACTUATOR**

**Installation**

1. Operate valve manually before installing actuator and place into open position.
2. If valve is equipped with mechanical position stops they should be removed, but care should be taken not to damage or remove necessary parts from the valve.
3. When actuator is supplied separately from valve, actuator will be shipped in valve open position and care should be taken to maintain proper alignment between the actuator and valve shafts. If actuator and valve shafts are not in correct alignment repeat operation number one (1) with correction as required.
4. Mount the actuator to the valve. The actuator is usually mounted parallel to the run of the pipe. Tighten all bolts and nuts evenly, taking care to center the actuator on the valve stem. It is often a good idea to cycle the actuator while the mounting bolts are somewhat loose. This will allow the unit to center itself.
5. Install and wire solenoid (if required) per diagram below or special wiring diagram with solenoid. 20 gauge stranded wire or better, should be used in field hook up.



**Note:** Standard operation for all R.C.S. Pneumatic/hydraulic actuators supplied with **factory mounted solenoid valves** is: clockwise rotation from open position to close position when solenoid is de-energized and counterclockwise rotation from close position to open position when solenoid is energized. (See Form 709 for installation instructions and parts list on R.C.S. Integral Solenoid.)

6. Operate actuator from one extreme to the other several times and check valve positions. When the actuator is first put into service, slight leakage past the piston(s) and other seals may be detected. This is due to the packing having been held in one position, tending to cause a hard seal. In such cases, the actuator should be operated through several cycles, thereby flexing the seals into normal operation.

**To Adjust Open and Close Valve Positions(if required)**

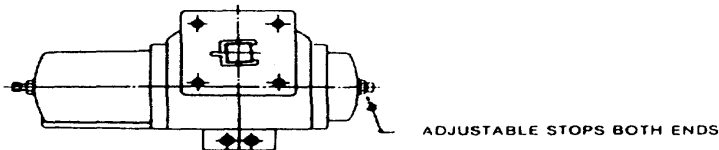

All models are equipped with externally adjustable stops to adjust individually the opening and closing strokes. These adjustable stops are necessary to compensate for the manufacturing tolerances of both the valve manufacturer and the actuator manufacturer.

## **ADJUST OPEN AND CLOSE VALVE POSITIONS (CON'T)**

1. Loosen locknuts on the position adjustment screws (screws are located at the end on each cylinder or end cap).
2. To adjust for correct positioning, rotate position adjustment screws clockwise (into cylinder) for over traveling condition or counterclockwise (out of cylinder) for under traveling condition. This procedure is applicable for adjusting both open and close positions.
3. Tighten locknuts on position adjustment screws and operate unit to check corrected positions. If further corrections are needed, repeat steps 1, 2, and 3.

### **To Manually Operate**

Manual operation of actuator and valve is provided in case of pressure loss or power failure. Standard wrenches fit either end of actuator output shaft or hexagon Actuator-Valve drive adapter.

## **MAINTENANCE**

Clear, dry air or gas is essential for long service life and satisfactory operation. If instrument air of this quality is not available, it is recommended that an inline filter be provided to prevent foreign particles from entering the cylinders of the actuator. Under most normal circumstances the actuator does not require additional lubrication, it should be remembered that most control valves and solenoids (with the exception of positioners) perform better on lubricated air. For this reason, an airline lubricator may be installed. Care should be taken to use only lubricants compatible with the seal in the actuator and control valves.

## **HYDRAULIC SERVICE**

All models of the Actuator can be furnished for using hydraulic fluid as an operating medium. When using water or other corrosive fluids as the operating medium, plating and coatings compatible with the respective operating medium, must be used.

## **STORAGE**

Indoor storage, if available is recommended for all actuators. Care should be taken to plug the cylinder ports, control valves ports and the body ports. Also, actuators should not be stored in an atmosphere harmful to resilient seals.

The piston(s) and other seals used in the Actuator are Buna -N material. Such synthetic materials have a shelf life of approximately 12 months at which point they go "dead". In normal use the life of these seals is indefinite, depending upon the amount of lubrication, etc. However, if the actuator sits for extended periods of non-use, the packing will have a tendency toward going dead. In such cases, when the actuator is called on to operate, leakage by the piston(s) will be experienced. The actuator in most cases will stroke the valve but then the gas will leak from the exhaust of the control valve. To prevent this from occurring we recommend that the actuator be cycled several times on at least 90 day intervals. This will keep the seals and piston(s) "alive" and flexible.

4025

Page 4026 DELETED

-2-

## CYLINDER DISASSEMBLY

### Safety First

The maintenance and operation of mechanical equipment SAFETY is the basic factor which must be observed at all times. Through the use of the proper clothes, tool and methods of handling serious contents cause injury, to you or your fellow worker can be prevented.

Throughout this manual are listed a number of safety precautions. Study them and follow them, also insist upon those working for you to do the same. Remember an accident is usually caused by someone's carelessness neglect or oversight.

### Type AA

#### Double Acting (Air To Air) Units:

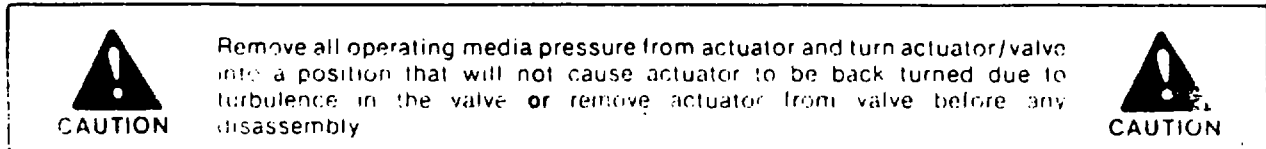

### Screw Attachment Models

At the base of the cylinder(s) are four (4) socket head cap screws. Alternately loosen, a little at a time, two screws across from each other. Similarly, loosen the remaining screws and remove by hand. Care should be taken when removing the last two screws as the cylinder could become free to drop or fall.

## CYLINDER RE-ASSEMBLY

### Screw Attachment Models

Replace cylinder "O" ring and air passage seals (it required) and carefully slide cylinder over piston and up to body. Install the ;socket head cap screws and tighten snugly by hand. Use a wrench and alternately tighten, a little at a time, two screws across from each other Similarly, tighten the remaining screws.

4027

Page 4026 DELETED

## ACTUATOR WEIGHTS IN POUNDS (APPROX.)

pe AA

PA-25 2.50 Lb.

## ACTUATOR DISPLACEMENT IN CUBIC INCHES — ONE 95° STROKE

Types AA	PA-25
DISPLACEMENT	6.13

## ACTUATOR FREE AIR CONSUMPTION - ONE 95° STROKE

The following formula may be used to determine the free air consumption for each actuator.

$$V = \frac{D \times P + 14.7 \times 60}{14.7 \times T}$$

V = Free Air Consumption Per Minute (SCFM)  
 D = Actuator Displacement (Cubic Feet)  
 P = Gauge Pressure (PSIG)  
 T = Actuator Operating Time (Seconds)

$$\text{Cubic Feet} = \frac{\text{CUBIC INCHES}}{1728}$$

## TROUBLESHOOTING

- Problem:** Actuator operates alone but will not operate valve.
- Instructions:**
- Check actuator nameplate to insure correct model and spring rating, if so supplied, is in use.
  - Check line pressure at actuator.
  - Check to insure correct solenoid is being used.
  - Check to insure that air lines are properly connected to solenoid and from solenoid to actuator.
  - Check to insure that electric power is properly connected to solenoid.
  - Check to see if actuator has been stored for any length of time without periodic cycling (see storage).

## LOCATING AND ORDERING PARTS

For ease and accuracy in identifying and ordering spare or replacement parts, use parts drawings and part lists on the preceding pages.

Data required from parts drawings and list are:

1. Part number
2. Name of part

To obtain replacement parts submit the following information from unit nameplate:

1. Serial number
2. Model number
3. Operating pressure

**Nameplate**



**RAYMOND CONTROL SYSTEMS**  
MORTON GROVE, ILLINOIS 60053

**MODEL**

**SER. NO.**

**MAX. P.S.I.**

PATENTED 19-12





CLIFFORD B. HANNAY & SON, INC., 600 EAST MAIN STREET  
WESTERLO, NEW YORK 12183 • TELEPHONE (518) 797-3791

# PARTS LIST

SERIES 7000  
Dual Inlet & Outlet Reel  
EFFECTIVE AUGUST 1, 1983

ROCKWOOD PART NO. 6185-1

DRAWING ISO-72

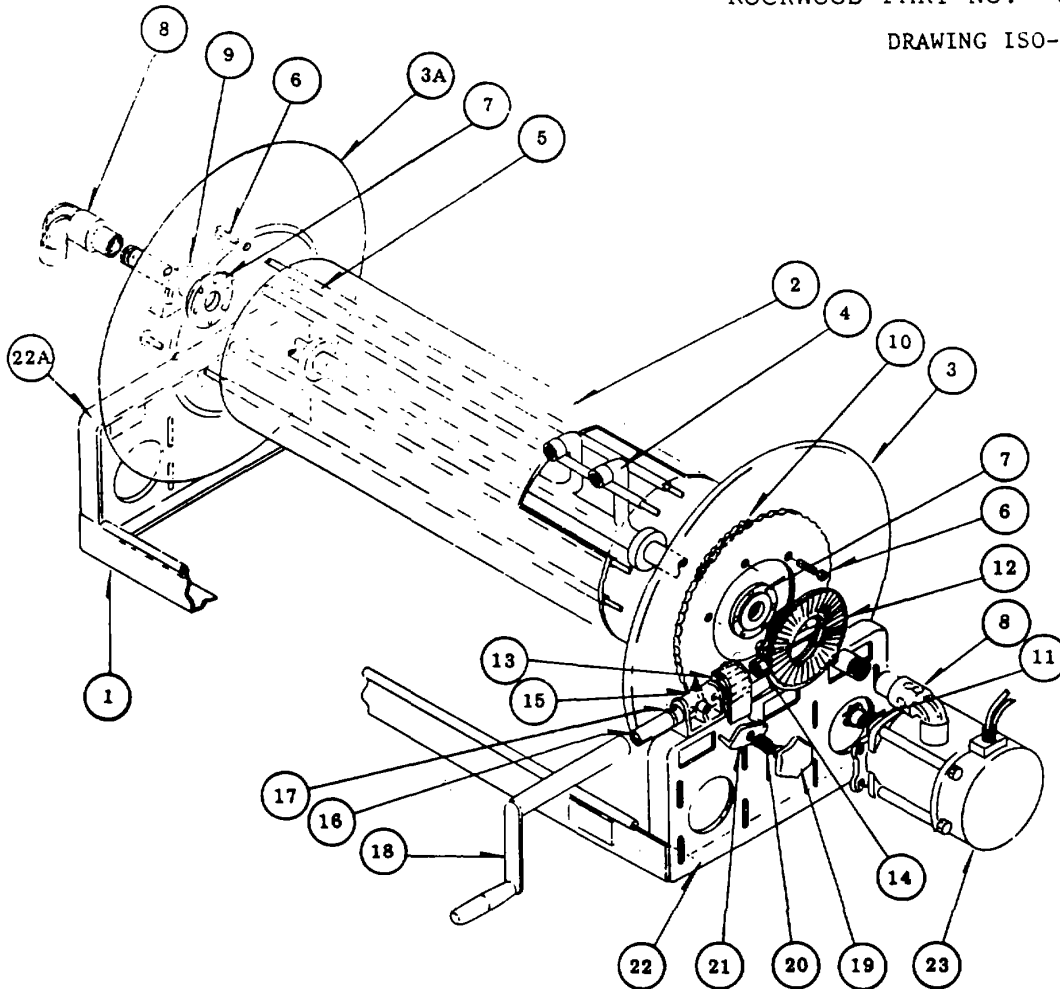

When ordering parts,  
**BE SURE TO SPECIFY COMPLETE MODEL NUMBER and SERIAL NUMBER OF REEL.**

Part No.	Description	Quantity	Part No.	Description	Quantity
ISO-72- 1	Front Foot	1	ISO-72-12	Ring Gear (H-26)	1
ISO-72- 1A	Rear Foot (Not Shown)	1	ISO-72-13	Pinion Gear	1
ISO-72- 2	Drum, 10 1/2" Diameter	1	ISO-72-14	5/8"-18 SAE Hex Nut	1
ISO-72- 3	Front Disc (23-24 Series)	1	ISO-72-15	H-2A Pinion Shaft Bearing	1
ISO-72- 3A	Back Disc (23-24 Series)	1	ISO-72-16	Pinion Shaft	1
ISO-72- 3	Front Disc (30-31 Series)	1	ISO-72-17	Pinion Shaft Collar W/Set Screw	1
ISO-72- 3A	Back Disc (30-31 Series)	1	ISO-72-18	H-18 Crank Handle	1
ISO-72- 4	Dual 1" Hub Assembly W/Risers	1	ISO-72-19	H-30 Brake Wheel	1
ISO-72- 5	3/8" Spacer Pipes	6	ISO-72-20	H-31 Brake Spring	1
ISO-72- 6	3/8" Carriage Bolts	6	ISO-72-21	H-3 Brake Pad	1
ISO-72- 7	EH-936 Washer	1 Per Disc	ISO-72-22	Front Frame (23-24 Series)	1
ISO-72- 8	1" 90° Swivel Joint	2	ISO-72-22A	Rear Frame (23-24 Series)	1
ISO-72- 9	1" S.A. Pillow Block Bearing	2	ISO-72-22	Front Frame (30-31 Series)	1
ISO-72-10	#35 Chain	1	ISO-72-22A	Rear Frame (30-31 Series)	1
ISO-72-11	11T35 Motor Sprocket	1	ISO-72-23	12 Volt Motor	1

1000 HP 2/84

H-8108-P-L

**FF028 SEAL REPLACEMENT KIT For FS59000-1616-01 Swivel Joints**

**Kit FF028 Contents**

Description	Quantity	Part Number
DUST SEAL	1	06-099-00
O-RING	1	22550-216
TEFLON BACK-UP RING	1	FF9552-216

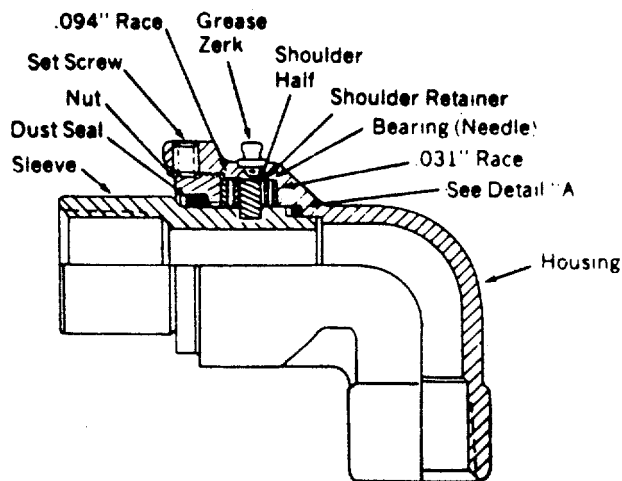

**SERVICE INSTRUCTIONS:**

1. Remove the sleeve assembly by backing off the set screw with a 1/e" hex head wrench. Then unscrew the nut completely with a screwdriver or spanner wrench.
2. Pull out the nut and sleeve assembly. One bearing and race may remain in the housing, however, these should also be removed. If the shoulder retainer comes off of the sleeve assembly, it should be reinstalled. It must cover the shoulder since the rear of this part acts as a bearing race.
3. Remove and discard the O-ring and back-up ring from the sleeve or housing. Remove the dust seal from under the nut, clean area and replace.
4. Wipe the housing and sleeve seal area clean. Apply an assembly lubricant, such as silicone grease to these surfaces. Lubricate the O-ring and place in the housing. Place the white teflon back-up ring on the O-ring. Again, make sure the skive cut is lined up as shown.
5. If the rear bearing and race were removed from the sleeve, they must be reinstalled. The .031" thick race is placed in the housing first with the bearing on top.
6. Insert the sleeve assembly into the housing. It is not necessary to force the sleeve. Allow the nut to slowly guide the sleeve into the casing with its threading action. Occasional pressure on the sleeve should make it possible to seat the nut almost entirely by hand.
7. Snug the nut with a spanner wrench (or screwdriver). Then, loosen the nut 1/4 to 1/2 turn (maximum) to avoid overtightening. Lock the nut with the set screw.

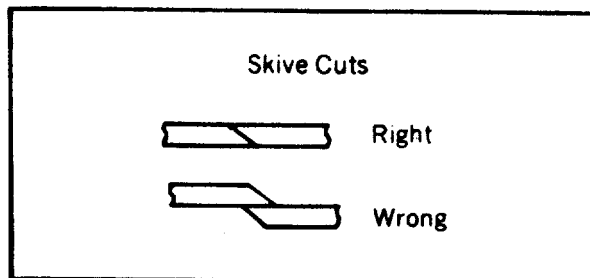
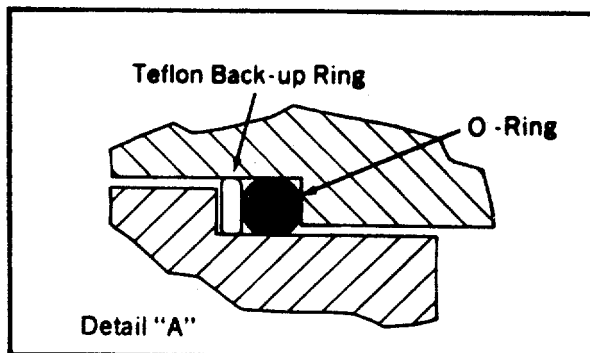

8. Use a grease gun to grease the swivel at the lubrication fitting until grease comes out of the relief hole. Check for smooth rotation to insure proper assembly.

**NOTE:** If, during disassembly, a problem is noted with the bearings or races such as cracks, kit number FF976 is recommended. The FF975 kit includes seals and bearings to completely refurbish the swivel assembly.

Aeroquip Corporation 1981

**1. DESCRIPTION OF CIRCUIT BREAKER**

The CDLM Circuit Breaker is normally used with Hannay Reels for protection of the rewind motor. This type of breaker must be manually reset by pressing firmly on the red pushbutton, if it is tripped for any reason. This insures that the problem will be corrected before the breaker is reset.

**2. WIRING PROCEDURES**

The circuit breaker is installed into the wiring system by cutting either wire leading to the hose reel motor and connecting the two resulting ends to the two terminals of the circuit breaker.

**3. MOUNTING**

The circuit breaker should be firmly mounted using the two mounting holes provided. The mounting position should be well removed from any abnormal sources of heat such as exhaust manifold and radiator, etc. To use the manual reset type satisfactorily a small mounting bracket, available from us as Part No. CB-1, should be used so that the reset button will be easily accessible when needed.

**4. AMPERAGE RATINGS**

The application will determine what amperage breaker is required. Under actual operating conditions the breaker should be of such a rating that when the hose reel motor is held in a stalled condition the breaker will open the circuit in no more than 30 seconds. To allow the circuit to remain closed for a longer period of time would begin to endanger the other components in the system. As a guideline, the following ratings would apply to motors used on Hannay Reels:

Reels (except Inverted Type) with 12 volt explosion-proof rewind motor: 50 amp. Circuit breaker.

**CAUTION**

**THIS CIRCUIT BREAKER IS NOT SUITABLE FOR USE WITH AC MOTORS.**

3 OF 5



**NOTE: FAILURE TO FOLLOW THESE INSTRUCTIONS MAY VOID THE WARRANTY.**

**Unpacking**

1. Unpack the reel and inspect for shipping damage.
2. Check wiring accessories against parts list on back of page under photo 1 or 2 depending on your model.

**Mounting the reel**

1. Fasten reel frame securely to a level surface.
2. Turn reel discs by hand. Spool should turn freely. If it binds, just adjust self-aligning bearings.

**Connecting inlet**

1. Threaded-type swivel joint inlets must be connected to the fluid supply by a flexible connector or the Hannay Warranty will be void.
2. Victaulic-type swivel joint inlet connections must be carefully aligned. Two victualic connections, correctly installed, will normally allow adequate flexibility for smooth rotation.
3. Install a union fitting as near as possible to the swivel joint inlet so the joint can be easily removed for servicing.

**Connecting hose**

1. Do not attach hose until reel has been installed and wired. Charge hose BEFORE winding on the reel to prevent excessive pressure on the drum when the hose is charged.
2. If the reel is equipped with the flanged outlet riser remove the entire riser from hub. Be careful not to damage the gasket. Apply thread compound to all threads and bushings. Attach the hose to the outlet riser and tighten securely. Make sure the gasket is seated properly.
3. Threaded or welded outlet risers cannot be removed to attach hose.
4. Press the electric rewind operating switch or turn the hand crank to wind hose on the reel.

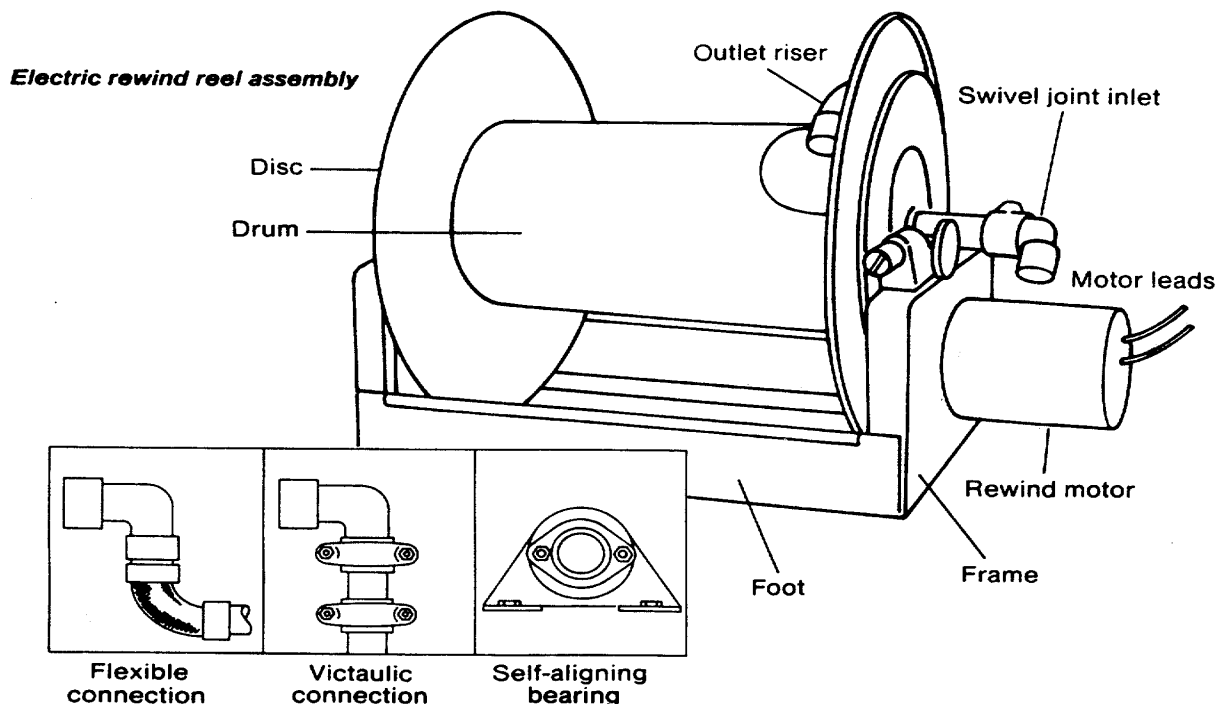

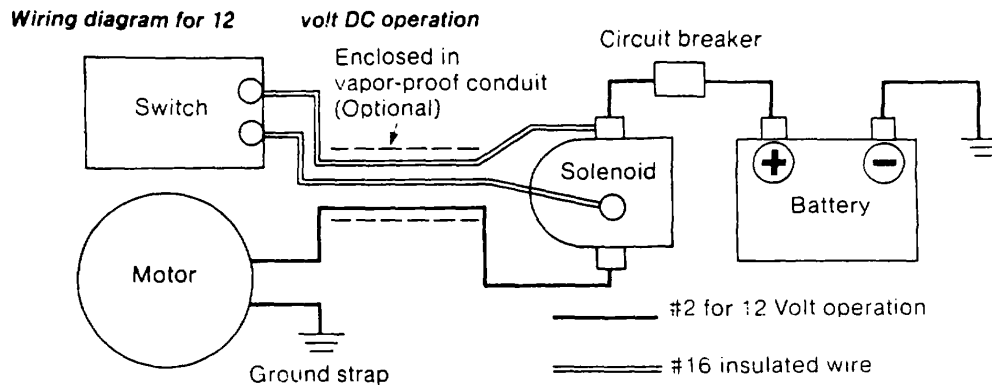

### Additional wiring materials required

The following are required but not supplied with the reel.

- insulated cable. minimum size No. 2 for 12 volt,
- #16 Twin insulated wire.
- Vapor-proof conduit. (Optional)
- Circuit breaker (see sticker on reel motor for amperage rating).
- Ground strap for reel.
- Wiring

1. The wiring diagram shows necessary connections between components. Placement will vary depending on the installation. IT IS IMPORTANT THAT ALL GROUND CONNECTIONS ARE GOOD FOR PROPER OPERATION. Solder all connections using rosin-core solder.
2. The solenoid should be mounted in the engine

compartment as close as possible to the battery and/or starter. It should be mounted vertically and securely grounded

3. Optional vapor-proof conduit may be used for wiring between the solenoid and motor/switch. A circuit breaker (not supplied) must be wired into the circuit between the solenoid and battery.
4. A ground strap must be securely fastened between the reel frame and a grounded part of the vehicle body.
5. Check all connections to be sure they are tight.
6. Tape all connections.
7. Seal the open end of the conduit, if used, with a sealing compound and wrap with plastic tape.
8. Hose reel motor rotation can be reversed by interchanging the two motor leads at the motor.

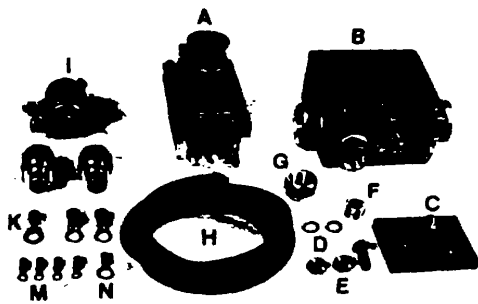

*Explosion-proof Switch and accessories supplied with EPJ 12V Reel*

- A. 1 - explosion proof push button switch
- B. 1 - cast aluminum junction box
- C. 1 - terminal block for junction box
- D. 2 - 5/16" internal lockwashers
- E. 1 - 5/16" x 1" round head screw with two brass hex nuts.
- F. 1 - 1/12" pipe plug
- G. 1" to 3/4" reducing bushing
- H. 6' - 16/2 Type SO cable
- I. 1 - solenoid control
- J. 2 - 1/2" strain relief connectors
- K. 1 - #4 terminal for 5/16" stud
- L. 2 - #8 crimp terminals for 5/16" stud
- M. 4 - #16 crimp terminals for #10-32 studs
- N. 1 - #16-14 crimp terminal for 5/16" stud



CLIFFORD B. HANNAY & SON, INC., 600 EAST MAIN STREET  
WESTERLO, NEW YORK 12183 • TELEPHONE (518) 797-3791

**SECTION III**  
**DISCHARGE DEVICES**



Proven under pressure around the world  
**R O C K W O O D**

**S Y S T E M S**  
**C O R P O R A T I O N**

TWIN AGENT HANDLINE  
ROCKWOOD INSTRUCTION MANUAL  
RIM 1434

P/N 510-1678

JUNE, 1982  
**FIRE PROTECTION AND VALVE PRODUCT DIVISION**  
**80 Second Street. South Portland, Maine 04106 Telephone (207) 799-3341 / TWX 710-221-1668**  
**4035**

TABLE OF CONTENTS

	<u>PAGE</u>
1.0 SCOPE.....	4037
2.0 NOZZLE DATA.....	4037
3.0 GENERAL DESCRIPTION.....	4037
4.0 OPERATING INSTRUCTIONS .....	4038
5.0 MAINTENANCE .....	4038
6.0 SPA.RE PARTS .....	4038
FIG. 1 DUAL AGENT HANDLINE PARTS LIST	



## 1.0 SCOPE

This manual contains operating instructions maintenance , :procedure and parts list for the Rockwood Twin Agent Handline Nozzle.

## 2.0 NOZZLE DATA

Hose Connections:

Foam Inlet - Red swivel coupling,  
1" - S NI Female National Fire hose

Dry Powder Inlet - Black swivel coupling  
1" - 8 Nil female National fire hose thread

Liquid Discharge Rate:	60 GPM @ 100 PSI Foam
Dry Powder Discharge Rate:	S-8 l 's/Sec. @ 250 PSI
-4 DRY POWDER DISCHARGE:	5-8 :3S/Sec. @ 100 PSI
Discharge Pattern Data:	

FFFF Barrel: Solid Stream - 60 feet effective range, fully dispersed stream - 15 feet wide at 26 feet range.

Dry Powder Barrel: 25 to 40 feet effective range.

FFFF Quality:       Expansion: 8 (Minimum)  
One quarter drainage time: 3 minutes (minimum),  
Per NFPA 412

## 3.0 GENERAL DESCRIPTION

The nozzle consists of a dual passageway (one for foam, the other for dry powder), valve shutoffs, discharge tubes and in the foam line there is a stream forming discharge tip and deflectors. Hose connections are made to the swivel couplings at the base of the frame assembly.

The discharge valves are operated by the levers in the center portion of the handline. The black handle operates the dry powder discharge and the red handle operates the foam solution. In the forward position (parallel with the discharge nozzles) the valve is closed and upright (perpendicular to the discharge nozzles) the valve is open.

The foam stream deflectors are operated by the lever mounted on the foam tube. The two position deflectors are operated by placing the lever fully forward for the dispersed pattern and all the way back for straight stream.

The foam passageway, operating handle and swivel coupling are color coated red. The dry powder nozzle, handle and swivel coupling are color coated black.

## 4.0 OPERATING INSTRUCTIONS

### 4.1 GENERAL:

**WARNING**

The discharge of large amounts of dry chemical may create hazards to personnel such as reduced visibility and temporary breathing difficulty.

The nozzle may be used right handed or left handed. It is held by placing one arm under the arm support - between the two swivel couplings and gripping the cross bar handle. The other arm is used to operate the discharge nozzles and deflectors. The nozzle is operated by selecting the desired agent and pulling on the valve handle.

**CAUTION**

The dry chemical discharge valve should always be in the fully open or fully closed position. Never throttle the discharge rate with this valve.

### 4.2 AGENT SELECTION

Foam Discharge - Red handle discharge valve.  
Deflectors - Open or closed by adjusting lever  
on foam discharge barrel.

Dry Powder Discharge - Black handle discharge valve.

## 5.0 MAINTENANCE

Inspect and manipulate all controls periodically to insure that they are in working order. Apply light silicone based oil to allow moving connections, sliding parts and friction points. There are no special tools required for maintenance or disassembly and assembly of this nozzle.

## 6.0 SPARE PARTS

The following list of items are the recommended list of spare parts.

<u>PART NUMBER</u>	<u>DESCRIPTION</u>	<u>QUANTITY</u>
6110-6	1¼" Ball Valve	1
6118-1	Toggle Clamp	1
6119-4	Swivel	1
110-3702-1	Adjustment Adapter	1
10-06665	Hose End Gasket	2

ENGINEERING DATA SHEET

ROCKWOOD FIRE PROTECTION SYSTEMS  
JET-X • WaterFOG • FogFOAM • FOAM

DUAL AGENT HANDLINE FOAM / DRY POWDER

P/N 510 - 1678

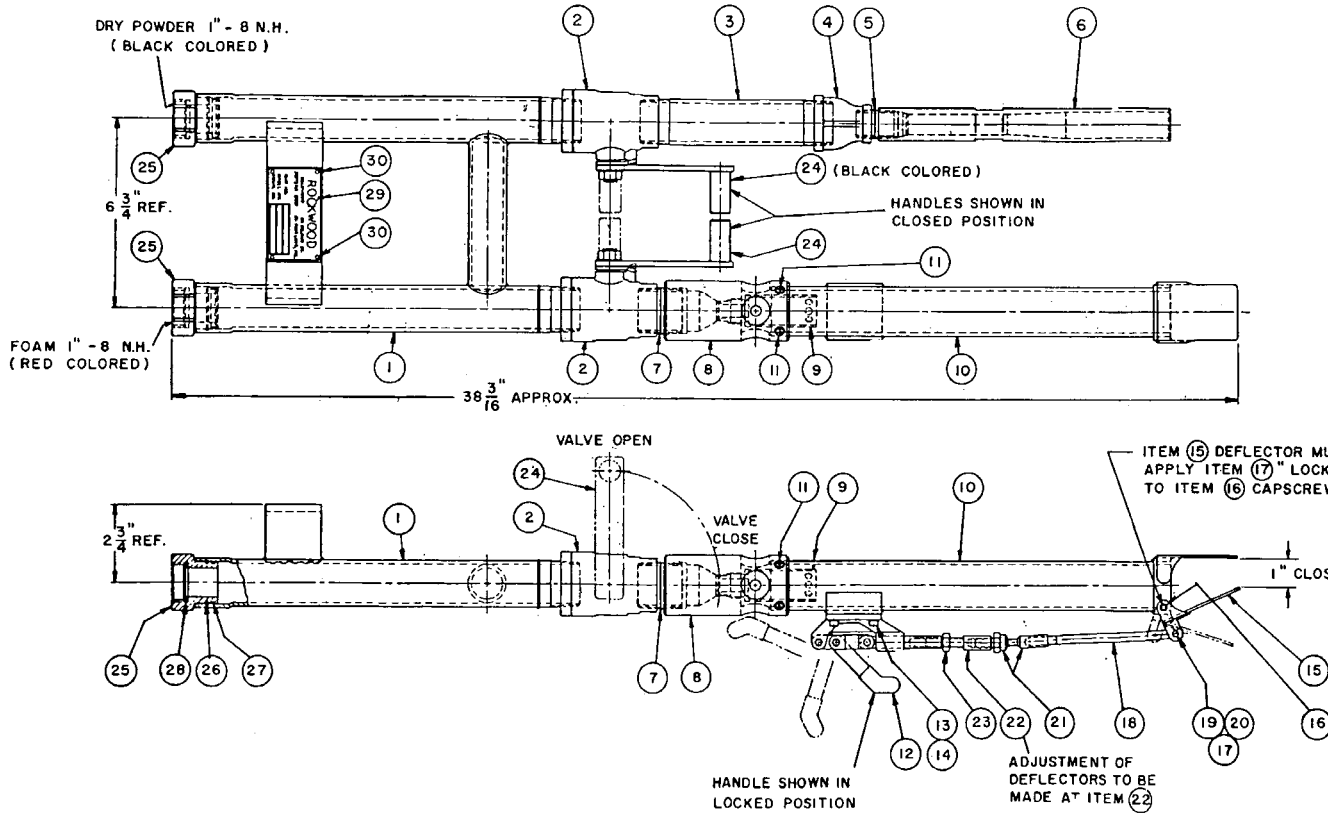

ROCKWOOD SYSTEMS CORP.

FIGURE I.

ROCKWOOD SYSTEMS CORP.

4039

Rockwood Systems Corporation  
 80 Second. Street  
 South Portland, Maine 04106

RIM-1434

DUAL AGENT HANDLINE - FOAM/DRY POWDER			FIG I
TITLE	PART NO	510-1678	
ITEM	QTY	PART NO.	PART NAME
1	1	510-1749-1	HANDLE
2	2	6110-6	1¼" BALL VALVE
3	1	4803-156H	1¼" NIPPLE
4	1	4426-12	1¼" x 3/4" REDUCING COUPLING
5	1	4803-97H	3/4" CLOSE NIPPLE
6	1	110-0942-3	DRY POWDER NOZZLE
7	1	4803-145	1¼" CLOSE NIPPLE
8	1	110-3691-1	BREECH
9	1	10-08441-2	FOAM TIP
10	1	510-1763-1	SHAPER WELD ASSY
11	4	251-10003	MACHINE SCREW
12	1	6118-1	TOGGLE CLAMP
13	4	152-10006	CAPSCREW
14	4	167-12007	LOCKWASHER
15	1	110-3704-2	DEFLECTOR, ACTIVE
16	2	152-08101	CAPSCREW
17	A/R	4259-7	LOKTITE
18	1	110-3703-1	ROD
19	1	152-54001	CAPSCREW
20	1	162-040Q1	MACHINE NUT
21	1	6119-4	SWIVEL, STRAIGHT
22	1	110-3702-1	ADAPTER, ADJUSTMENT
23	1	161-05007	HEX NUT
24	2	510-1762-1	VALVE HANDLE
25	2	110-3687-1	SWIVEL COUPLING
26	2	284-15000	RETAINING RING
27	2	780-01125	"o" RING
28	2	10-06665	GASKET
29	1	10-04421	NAMEPLATE
30	4	254-02002	DRIVE SCREW
DATE	REV	PREPARED BY	APPROVED BY
			Page 4041 DELETED
			PAGE 2 OF 2



Proven under pressure around the world  
ROCKWOOD SYSTEMS  
CORPORATION

REMOTE MANUAL TWIN AGENT TURRET  
FOAM/DRY POWDER

PART No, 510-1679  
LOG, No, RIM-1433

MAY, 1982

REVISED: AUG., 1982

FIRE PROTECTION AND VALVE PRODUCT DIVISION

80 Second Street. South Portland. Maine 04106 Telephone (207) 799-3341 / TWX 710-221-1668

**Page 4041 DELETED**

**4042**

## TABLE OF CONTENTS

	<u>PAGE</u>
1.0 SCOPE.....	4044
2.0 INTRODUCTION.....	4044
3.0 FIGURES LIST.....	4044
4.0 OPERATING INSTRUCTIONS.....	4045
5.0 MAINTENANCE.....	4045
6.0 SPARE PARTS.....	4046
FIGURE I            REMOTE MANUAL TWIN AGENT TURRET.....	4047
PARTS LIST.....	4048
FIGURE II            REMOTE MANUAL TURRET, SUB ASSY.....	4049
PARTS LIST.....	4050
FIGURE III           SHAPER - AFFF.....	4054
PARTS LIST.....	4055
FIGURE IV            DRY CHEMICAL NOZZLE.....	4056
PARTS LIST.....	4057

### 1.0 SCOPE

This manual defines the following for the Rockwood Remote Manual Twin Agent Turret P/N 510-1679.

- a) Introduction
- b) Operating Instructions
- c) Maintenance
- d) Recommended Spare Parts

### 2.0 INTRODUCTION

Twin Agent Turrets are used throughout the fire protection industry on Class B and C fires for rapid extinguishment, knock down capabilities and securing the hazardous area.

Typical uses for Twin Agent Turrets consist of:

- a) Municipal Airports
- b) Government - Military Installations
- c) Crash trucks and fast response vehicles

The Rockwood Twin Agent Turret is a remote manual, panel mounted, foam/ dry powder turret nozzle; with 180° rotation (minimum), 80° elevation and 20° depression capabilities.

Discharge ranges can be sized to meet hazard requirements with the following ranges.

Foam/Water 100-400 GPM	Dry Chemical 10-25 Lbs/Sec.
------------------------	-----------------------------

All functions of the turret can be controlled from inside the cab including;

- |               |                       |
|---------------|-----------------------|
| a) Elevation  | c) Rotation           |
| b) Depression | d) Foam/Water Pattern |

Rockwood's Dual Agent Turret is designed to discharge foam and dry chemical either separately or simultaneously.

3.0	<u>FIGURES</u>	<u>PAGE</u>
I.	Remote Manual Twin Agent Turret, PN 510-1679 Turret Top Assembly .....	4047
IA.	Remote Manual Twin Agent Turret w/Foam Nozzle .....	4049
	PN 510-1679-6	
II	Remote Manual Turret, Foam Solution Waterway .....	4051
	PN 10-09170-9, Turret Sub Assembly	

3.0	<u>FIGURES</u> (Cont.)	<u>PAGE</u>
III.	Shaper Assembly, PN 510-1591 .....	4054
	Foam/Water Discharge Nozzle	
IV.	Dry Chemical Nozzle, PN 510-0288.....	4056
	Dry Chemical Discharge Device	

4.0 OPERATING INSTRUCTIONS

After the turret has been properly mounted on the vehicle and the foam/water (2" 111/2 NPT) and dry powder (11/2" 111/2 NPT) inlets have been hooked up, tested and the handle latch (Item 50, Figure II, page 4051) has been properly aligned and mounted on the foam/water inlet, the turret may be operated as follows:

Refer to Figures I, Page 4047 and II, Page 4051

Simultaneous or individual discharges may be accomplished by activating the corresponding control valve. Elevation and rotation are accomplished by raising, lowering and rotating the manual control arm (Item 44, Figure II, page 4051).

The foam pattern may be varied from straight stream (push) to fully dispersed (pull) by adjusting the pattern control cable (Item 12, figure 1, page 4047).

To prevent damage to the turret, it should always be locked in the travel position when it is not in use. This is accomplished by locking the manual control arm on to the handle latch.

Refer to the maintenance section after discharging turret.

5.0 MAINTENANCE



After each use of the turret with foam, the turret and supply lines should be thoroughly flushed with clear water to remove all foam residue.



The discharge of large amounts of dry chemical may create hazards to personnel such as reduced visibility and temporary breathing difficulty.

After each use of the turret with dry powder, the turret and supply lines should be thoroughly purged with gas to remove all dry powder residue.

The turret is virtually maintenance free. Use touch-up paint, rust preventative and lubrication as required.



6.0 SPARE PARTS

The following list is the suggested spare parts for P/N 510-1679; Remote Manual Twin Agent Turret.

<u>PART NUMBER</u>	<u>DESCRIPTION</u>	<u>QUANTITY</u>
10-06917	Clamp	1
4793-80	Clamp	1
510-0353-4	Hose Assembly	1
4748-341	Quad. Ring	1
10-02975	Gasket	1
780-01228	"O" Ring	1
780-01326	"O" Ring	1
780-01224	"O" Ring	1
10-07732	Head Seal	2
780-01237	"O" Ring	2
780-01234	"O" Ring	2
10-07122	Wearing Ring	2
185-03140	Retaining Ring	4
10-02864-1	Auto Drain Valve	1
334-10001	Tube Connector	1
780-11014	U Packing	2
10-06051	Nyliner	2

**4046**

**-3-**

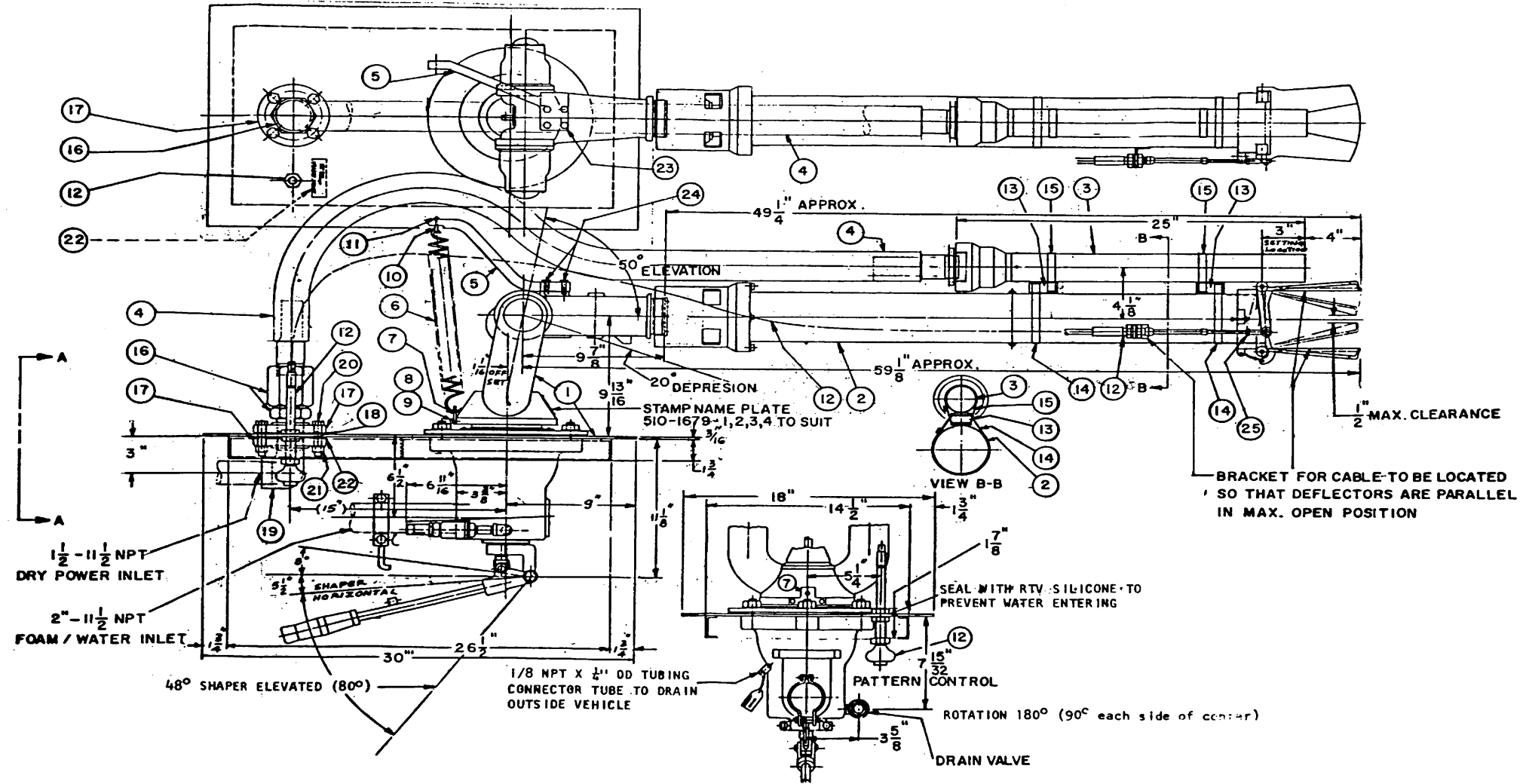

ROCKWOOD SYSTEMS CORP.

1 of 2  
Figure 1.

4047

Rockwood Systems Corporation  
 80 Second Street  
 South Portland, Maine 04106

RIM-1433

TITLE	REMOTE MANUAL TWIN AGENT TURRET PART NO. 510-1679			FIG. 1
ITEM	QTY	PART NO.	PART NAME	
1	1	10-09170-9,-10	REMOTE MANUAL TURRET	
2	1	510-1591	SHAPER ASSY	
3	1	510-0288	NOZZLE DRY CHEMICAL	
4	1	510-0353-4	HOSE ASSY, DRY POWDER	
5	1	110-0716	SPRING BRACKET	
6	1	110-0587	C'BALANCE SPRING	
7	1	10-08469	ANCHOR BRACKET	
8	2	152-04004	CAPSCREW	
9	2	167-1200+	LOCKWASHER	
10	1	4354-1	EYEBOLT	
11	1	161-04012	HEX, NUT, ESNA	
12	1	4593-3	CABLE PUSH PULL	
13	2	510-1748-1	SHAPER SPACER ASSY	
14	2	4793-80	CLAMP WORM DRIVE	
15	2	10-06917	CLAMP	
16	1	6108-17	HYDRAULIC SWIVEL	
17	2	4816-3	FLANGE, SCREWED	
18	2	4465-3	RING GASKET	
19	1	4467-12	ELBOW, 90°	
20	4	152-08030	HEX BOLT	
21	4	161-08001	HEX NUT	
22	1	10-08466	NAMEPLATE	
23	4	152-05026	CAPSCREW, HEX HEAD	
24	4	167-12010	LOCKWASHER	
25	1	161-04005	HEX, NUT JAM	
DATE	REV	PREPARED BY	APPROVED BY	PAGE 2 OF 2

# TURRET REMOTE MANUAL TWIN AGENT

-6 ASSY

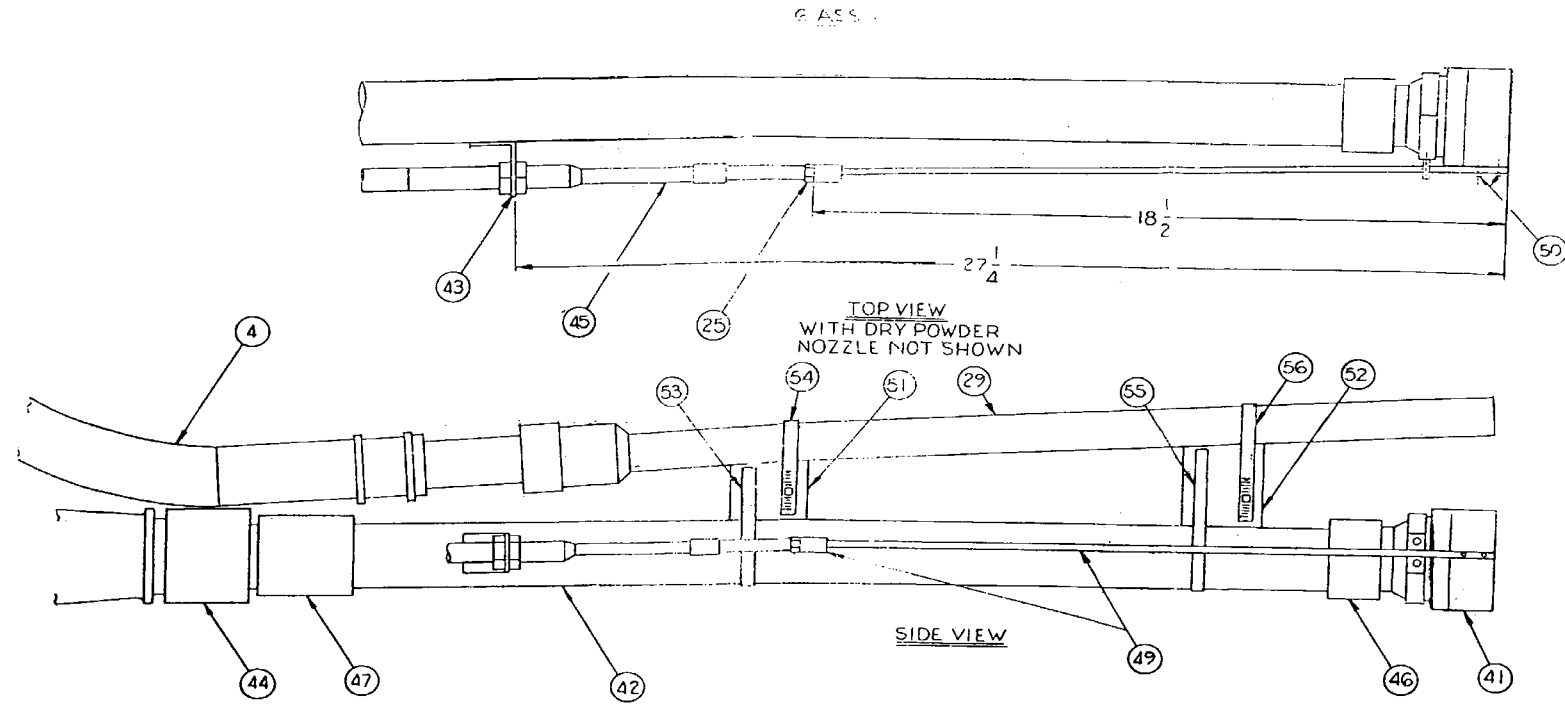

FIGURE 1A  
4049 1 of 2

Rockwood Systems Corporation  
 80 Second Street  
 South Portland, Maine 04106

RIM 1433

TITLE		REMOTE MANUAL TWIN AGENT TURRET PART NO. 510-1679-6 TURRET W/FOAM NOZZLE		FIG. 1A
ITEM	QTY	PART NO.	PART NAME	
1				
2				
3				
4	1	510-0353-4	HOSE ASSY, DRY POWDER	
5	1	110-0716	SPRING BRACKET	
6	1	110-0587	C'BALANCE SPRING	
7	1	10-08469	ANCHOR BRACKET	
8	2	152-04004	CAPSCREW	
9	2	167-12009	VLOCKWASHER	
10	1	4354-1	EYEBOLT	
11	1	161-04012	HEX NUT	
22	1	10-08466	NAMEPLATE	
23	4	152-05026	CAPSCREW	
24	4	167-12010	IOCKWASHER	
25	1	161-04013	HEX NUT, JAM	
29	1	510-0288-2	DRY CHEMICAL NOZZLE	
32A	1	10-04421	GENERAL NAMEPLATE	
32B	4	154-02003	SELF TAP SCREW	
41	1	510-2148-1	AFFF NOZZLE	
42	3.33 FT.	245-10102	PIPE	
43	1	110-0332-8	CABLE BRACKET	
44	1	6192-6	ADAPTER	
45	1	4593-7	PUSH PULL CABLE W/VERNIER CONTROL	
46	1	4523-12	COUPLING	
47	1	6454-1	ADAPTER	
48				
49	1	510-2186-1	ACTUATOR ROD CON OR	
50	2	252-60002	SCREW	
51	1	10-09170-11	REMOIE MANUAL TURRET	
DATE	REV.	PREPARED BY	APPROVED BY	PAGE 2 OF 2

REMOTE MANUAL TURRET

P/N 10-09170-9, -10

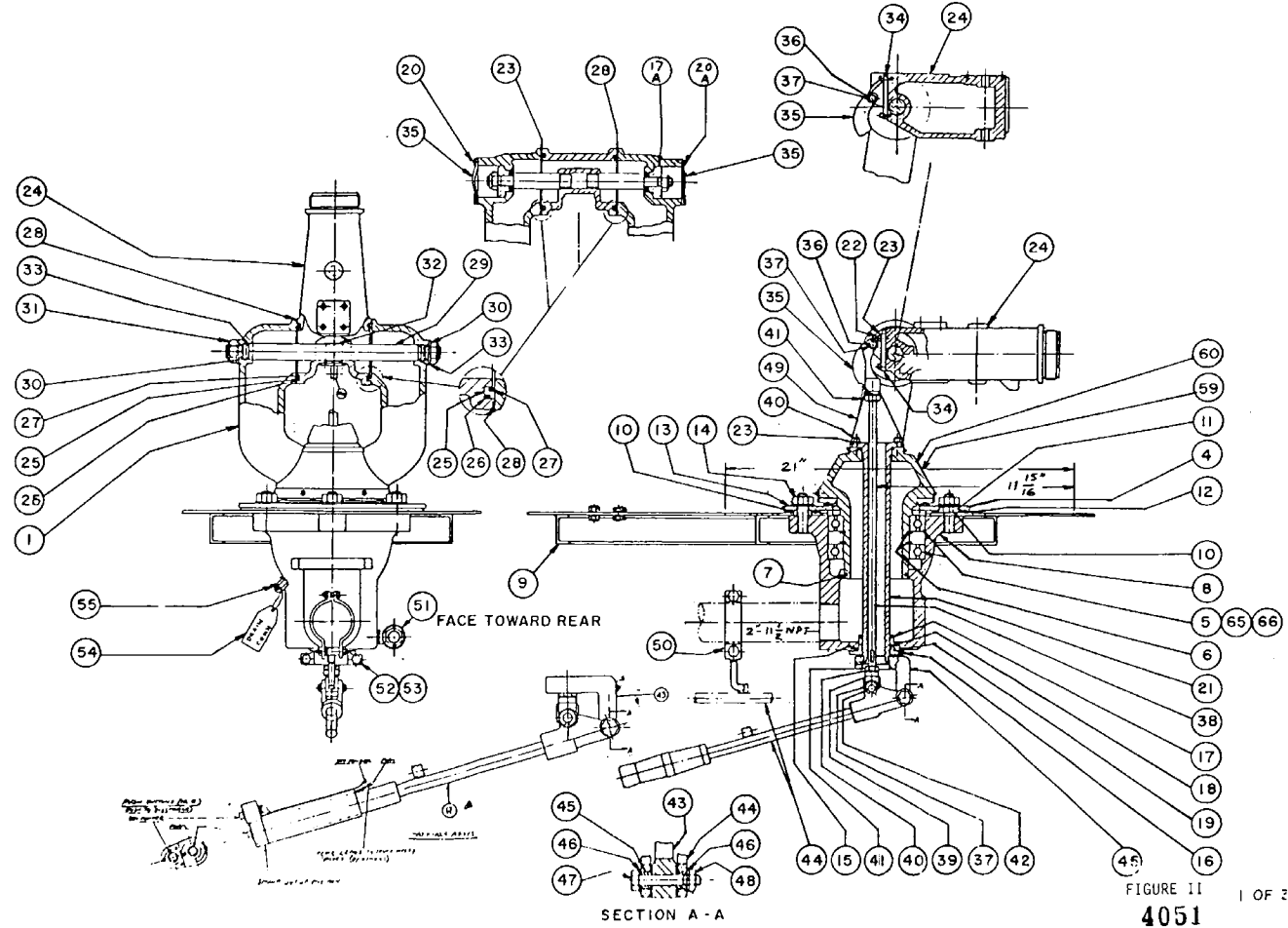

ROCKWOOD SYSTEMS CO

FIGURE II.  
1 of 2

4051

REMOTE MANUAL TURRET			FIG. II
TITLE	PART NO. 10-09170-9		
ITEM	QTY	PART NO.	PART NAME
1	1	10-04526	YOKE (BODY): BRONZE
2			
3			
4	1	10-02969	BODY RET.RING ASSY
5	2	10-02580	BEARING: STEEL
6	2	185-39330	RETAINING RING
7	1	4748-341	QUARD RING
8	1	10-04556	BASE ASSY
9	1	10-09106-2	MOUNTING PLATE
100A	4	11-02973	SPACER COLLAR
10	8	167-11013	LOCKWASHER
11	2	161-10008	HEX NUT
12	1	10-02975	GASKET
13	6	165-40004	WASHER
14	6	161-10009	HEX NUT
15	1	780-01228	"O" RING
16	1	10-04531	DRIVE SHAFT BUSHING
17A	2	10-07119	BODY BEARING
17	1	780-01326	"O" RING
18	1	10-04536	DRIVE SHAFT BEARING
19	6	151-08008	MACHINE SCREW
20A	2	161-10012	HEX NUT
20	1	780-01224	"O" RING
21	1	10-04532	DRIVE SHAFT
22	P	152-04009	CAPSCREW
23	8	167-12009	LOCKWASHER
24	1.	110-0129-2	HEAD
25	2	10-07732	HEAD SEAL
26	2	780-01237	"O" RING
27	2	780-01234	"O" RING
28	2	10-07122	WEARING RING
29	1	10-07222	BODY SHAFT
30			
31	2	161-10012	HEX NUT ESNA
DATE	REV.	PREPARED BY	APPROVED BY

Rockwood Systems Corporation  
 80 Second Street  
 South Portland, Maine 04106

RIM-1433

TITLE	REMOTE MANUAL TURRET PART NO. 10-09170-9			FIG II
ITEM	QTY	PART NO.	PART NAME	
32	2	10-06051	NYLINER	
33	2	780-11014	U PACKING	
34	1	10-07776	CLEVIS PLATE	
35	1	10-04529	ELEV. ROD CLEVIS	
36	1	10-04546	ELEV. ROD CLEVIS PIN	
37	4	185-03140	RETAINING RING	
38	1	10-04544	ELEVATION ROD	
39	1	10-04543	ELEVATION ROD CONN.	
40	2	167-12013	LOCKWASHER	
41	2	161-08014	HEX NUT	
42	1	10-04545	CONNECTOR PIN	
43	1	10-04555-2	CLEVIS HANGER	
44	1	10-04542	MANUAL HANDLE	
45	2	10-05105	BUSHING,ELEV. LINK	
46	2	10-05182	CLEVIS WASHER	
47	1	152-05041	CAPSCREW	
48	1	161-05005	HEX NUT	
49	1	10-07406	ELEV. ROD BOOT	
50	1	10-04547	HANDLE LATCH	
51	1	510-0370-2	AUTO. DRAIN VALVE	
52	2	152-05018	CAPSCREW	
53	2	167-12010	LOCKWASHER	
54	1		PAPER TAG	
55	1	334-10001	TUBE CONNECTOR	
56				
57				
58				
59	1	10-04421	NAMEPLATE	
60	4	154-02003	SELF TAP SCREW	
65	A/R	4438	DRY FILM LUBRICANT	
66	A/R	4474	WATER REPELLANT GREASE	
67	1	510-1875-1	MANUAL HANDLE ASSY	
DATE 9/2/82	REV. A	PREPARED BY	APPROVED BY	PAGE 3 of 3



SHAPER - AFFF  
PART No. 510-1591

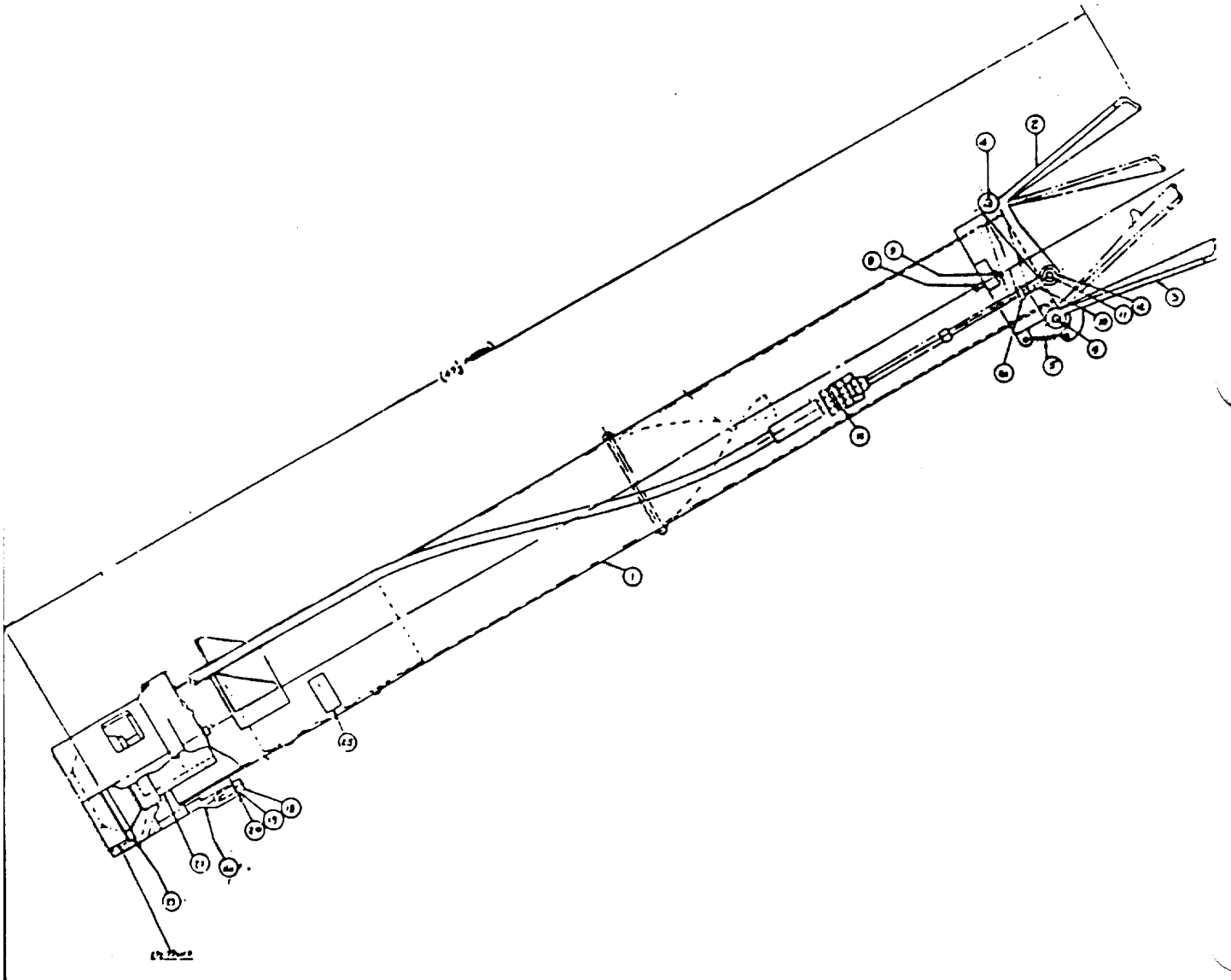

FIGURE III.

DRAWN: GPL

Rockwood Systems Corporation  
 80 Second Street  
 South Portland, Maine 04106

RIM- 1433

TITLE		MONITOR SHAPER ASSY - AFFF		FIG. III	
PART NO.		510-1591			
ITEM	QTY	PART NO.	PART NAME		
1	1	510-1633-1	SHAPER SUB-ASSY - ALUMINUM		
2	1	10-08507	DEFLECTOR ACTIVE - ALUMINUM		
3	1	10-08508	DEFLECTOR SLAVE - ALUMINUM		
4	4	274-10001	SPIROL PIN - ST. STEEL		
5	1	6040-1	SPRING - ST. STEEL		
6					
7					
8	1	251-10052	MACHINE SCREW, ROUND HEAD - STEEL		
9	1	161-03004	HEX NUT - STEEL		
10	1	10-05836	ROD END, FEMALE		
11	1	152-04035	CAPSCREW, HEX HEAD - STEEL		
12	1	161-04010	HEX NUT, PALNUT - STEEL		
13					
14	1	110-0332-2	CABLE BRACKET - ALUMINUM		
15					
16	1	110-3576-2	BREECH - ALUMINUM		
17					
18	8	152-05005	CAPSCREW, SOC. HEAD - STEEL		
19	8	165-20001	WASHER, PLAIN - STEEL		
20	8	267-16008	LOCIKWASHER - ST. STEEL		
21	1	510-1663	DISPERSION ORIFICE		
22					
23					
24	1	161-04005	HEX NUT JAM - STEEL		
25	1	10-07364	NAMEPLATE		
DATE	REV.	PREPARED BY	APPROVED BY	PAGE 2 of 2	

ENGINEERING DATA SHEET

ROCKWOOD FIRE PROTECTION SYSTEMS

JET - X \* WaterFOG \* FogFOAM \* FOAM

DRY CHEMICAL NOZZLE

PART NO. 510-0288

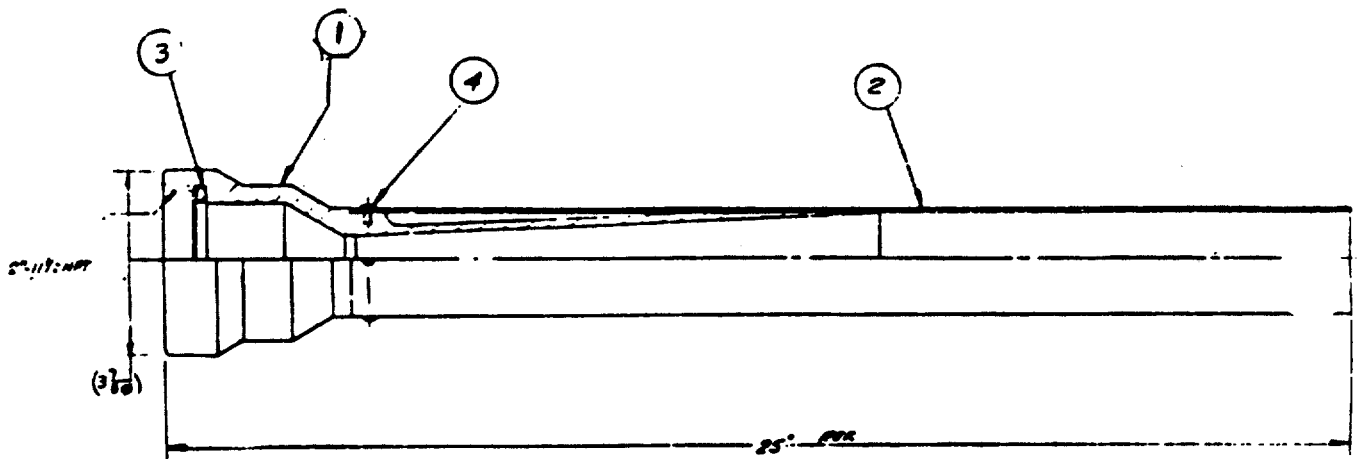

FIGURE IV.

REPLACEMENT PARTS LIST FOR FIG. NO. IV				RIM- 1433
TITLE				
ITEM	QTY	PART NO.	PART NAME	
1	1	110-0546	NOZZLE BODY	
2	1	110-0545	SHAPER NOZZLE	
3	4	151-10002	MACHINE SCREW ¼" LG.	
4	1	10-04790	GASKET	
DATE	REV.	PREPARED BY	APPROVED BY	PAGE 2 of 2
6/16/81				

REVISION RECORD		REV BY	APP'D
NO.	DESCRIPTION	DATE	DATE
1	ISSUED FOR FABRICATION		

BILL OF MATERIAL				
QUAN.	REQ'D	ITEM	REV	
		NO. 1	NUMBER	
			DESCRIPTION	
			MAT'L	

- NOTES:**
1. PAINT ALL EXPOSED SURFACES (EXCEPT NAMEPLATES AND BALL VALVES) PER ROCKWOOD STANDARD PAINT SPECIFICATION NO. MC-858 STEPS 1 & 2 ONLY.
  2. ODD LENGTHS OF PIPE MUST BE CUT AND THREADED AS REQ'D AT ASSEMBLY. CUT AND THREAD FROM STOCK SUPPLIED AS ITEMS 22, 50, 45, & 9.
  3. NAME NAMEPLATE (TANK) ITEM NO. 1 & 2.
  4. SET REGULATORS AS NOTED.
  5. SUPPORT PIPE AS REQUIRED USING ITEMS 82, 83, 84, 85 & 125.
  6. SECURE HOSE REELS W/ (4) 3/8" - 16 BOLTS LOCATED FROM HOLES IN HOSE REEL FRAME W/ ITEMS (2) & (10) (DRILL 4-3/4" DIA HOLES).
  7. USE (2) BETWEEN (1) & (12).

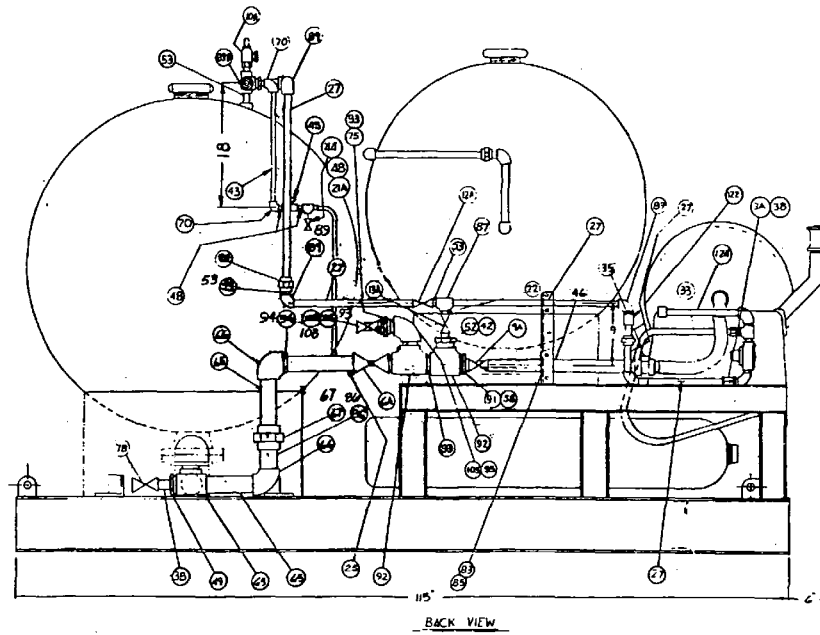
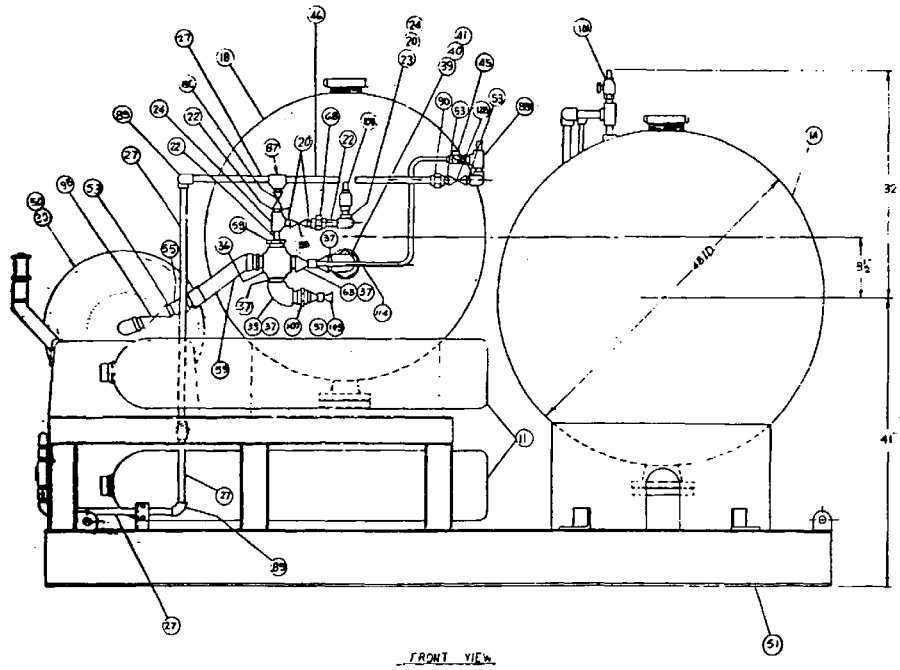

DRAWN BY: [Signature] CHECKED BY: [Signature] APPROVED BY: [Signature]	<b>ROCKWOOD SYSTEMS CORPORATION</b> 640 E. MAIN ST., LANCASTER, TX 75146 TITLE: TWIN AGENT SPRAY TANK 1500/250 W/500 LB DRY CWP TANK & 250 GAL AFFF TANK REV: [Number] SCALE: 3/16" = 1"	NEXT ASSY: C1803100 HOVIFEM ED. NO. 17 0750 DWG. NO. 510-2120 REV. E CODE 15HT 2 OF 4
--	--	--

QUANTITY REQ'D.	-4	-3	-2	-1	ITEM NO	PART OR IDENTIFYING NO	NOMENCLATURE OR DESCRIPTION	MATERIAL	SPECIFICATIONS OR REMARKS
						(1) KFT 131 (59556)	BAR, GRAB 1/4" O.D	CHROME SL	
						(2) KFT 132 (33556)	BRACKET & ATTACHING HARDWARE		
							SKID UNIT FRAME		
					(2)	KFT 005 (59556)	ANGLE, 1 1/2 x 1 1/2"	12GA	
					2	COMMERCIAL	5/8" x 1 1/2" BOLTS		
					2	"	FLAT WASHERS		
					2	"	LOCK WASHERS		
					2	"	NUTS		
					21	125 144-01440	PLATE, 1/8" THK x 1 W.	STEEL	
					2	124 510-2135-2	HOSE ASSEMBLY		
					1	123 4771-105	BUSHING 1/2 x 1/4	M.I.	
					1	122 4738-8	45° ELL, 1"	M.I.	
					NR 121	4259-1B	LOCTITE		
					NR 120	744-10006	NEOPRENE, 1/4" THK.		10 @ 4' x 6' (.042 SQ. FT.)

QUANTITY REQ'D.	-4	-3	-2	-1	ITEM NO	PART OR IDENTIFYING NO	NOMENCLATURE OR DESCRIPTION	MATERIAL	SPECIFICATIONS OR REMARKS
					9	119 4507-5	RIVET, PO" 3/16" DIA.	ALUM	(.250-.375 GRIP)
					1	118 110-3966-1	FILL PIPE	P-U-C	SHIP LOOSE
					1	117 6457-1	FUNNEL (FOAM)	POLYETHYLENE	SHIP LOOSE
					1	116 110-4005-1	FUNNEL (DRY CHEMICAL)	STEEL	SHIP LOOSE
					8	115 4570-2	TUBE FITTING MALE CONNECT	BRASS	SHIP LOOSE
					163	114 4321-5	TUBING, 1/4"	COPPER	SHIP 40.0 LOOSE
						113			
						112			
						111			
						110			
					1	109 509-0663-4	1 1/2" BALL VALVE	BRASS	PNEUMATICALLY ACTUATED
					1	108 509-0663-4	1 1/2" BALL VALVE	BRASS	PNEUMATICALLY ACTUATED
					1	107 4935-8	UNION 1 1/2"	M.I.	
					1	106 110-3970-1	NAME PLATE	ALUM.	INSTRUCTION & MAINT
					1	105 4649-12E	ELBOW, 90 1 1/2"	BRASS	
					2	104 4507-11	RIVET, POP 3/16" DIA.	ALUM.	(.500-.625 GRIP)
					1	103 110-3147-1	NAME PLATE	ALUM.	
					4	102 152-0601B	CAP SCREW, HX HD	STEEL	3/8-16 x 3/8"
					24	101 161-06021	ESNA NUT	STEEL	3/8-16
					5	100 5068-9	TEE 1/2"	STEEL	(2000#)
					2	99 5070-9	ELBOW-90 1/2"	STEEL	(2000#)
					100	98 5728-4	HOSE 1/2" ID - HI-PRESS	RUBBER	1" I.D. 8A-83Y 10YH LOT 76 3017 (5 LOCATIONS)
					5	97 6188-10	HOSE FITTING 1/2" MPT MALE	STEEL	
					5	96 5729-7	HOSE FITTING 3/8" SWIVEL	STEEL	(3/8-16 THD SIZE)
					5	95 6169-13	ELBOW 90°-2" MPT x 3/4"	1/2" TAP	STEEL 3/4" FLARE (3/4" MPT)
					1	94 4771-427	BUSHING 2" x 1 1/2"	BRASS	
					5	93 4439-169	CLOSE NIPPLE, 1 1/2"	BRASS	
					2	92 4648-12E	TEE 1 1/2"	BRASS	
					1	91 4771-422	BUSHING, 1 1/2" x 1"	BRASS	
					6	90 4936-6	UNION, 1"	M.I.	
					16	89 4204-8	ELBOW 90, 1"	M.I.	
					1	88A 508-046-5	RELIEF VALVE		SET AT 200 PSI
					1	88B 508-046-5	RELIEF VALVE		SET AT 200 PSI
					4	87 4206-23	TEE, 1 x 1 x 1/2"	M.I.	
					2	86 4439-193	CLOSE NIPPLE, 2"	BRASS	
					66	85 196-10003	ANGLE 1 1/2" x 1 1/2" x 1/4"	STEEL	SUPPORT ANGLE (CUT ARE REQUIRED)
					2	84 4636-3	U BOLTS W/NUTS, 1/2"	STEEL	
					5	83 4636-5	" " " " 1"	STEEL	
					5	82 4636-1	U BOLTS W/NUTS, 1/4"	STEEL	

C 510-2120

P/N	TOTAL QTY
M802-662080	5
M802-662040	3
509-0663-4	4

THIS DRAWING INCLUDING ALL INFORMATION CONTAINED THEREON IS THE EXCLUSIVE PROPERTY OF ROCKWOOD. IT IS TO BE KEPT IN CONFIDENCE AND NOT TO BE REPRODUCED OR COPIED IN WHOLE OR IN PART FOR ANY PURPOSE OTHER THAN THAT FOR WHICH DISCLOSED. THIS DRAWING IS TO BE RETURNED ON DEMAND TO ROCKWOOD.

UNLESS OTHERWISE SPECIFIED DIMENSIONS ARE IN INCHES			DRAWN		ROCKWOOD Systems Corporation	
FRACTIONS	DECIMALS	ANGLES	DATE	DATE	80 Second Street	
1	2	1	1-11-85	1-11-85	South Portland, Maine 04106	
ALL SURFACES			DATE	DATE	TWIN AGENT SKID RTA	
MATERIAL			APPROVED	DATE	1500/250 W/1500 DRY	
			DESIGN		CHEM. & 250 GAL AFFF TANK	
			ENG		REF DWG NO	
			MFG		SCALE	
					WT	
					CODE	
					SHEET 4 OF 4	

4059

QTY	ITEM NO.	PART OR IDENTIFYING NO.	NOMENCLATURE OR DESCRIPTION	MATERIAL	SPECIFICATIONS OR REMARKS
(2)	B16	—	RED. BISHING 1/4 x 1/8	BRASS	PART OF 50-1869-3
2	B1F	4439-29	NIPPLE 1/4 x 1 1/2" LONG	BRASS	
(7)	B1E	—	TEE 1/4"	BRASS	
(5)	B1D	—	HOSE 18' LONG	—	
(2)	B1C	—	POPPET VALVE 1/4"	BRASS	THESE PARTS INCLUDED IN 510-1869-3 ASSY. (ITEM 4)
(2)	B1B	—	SAFETY RELIEF VALVE	—	
(5)	B1A	—	QUICK RELEASE VALVE	—	
(2)	B0	—	1/4" CHECK VALVE	BRONZE	
2	78	6187-1	CAB ACTUATOR	—	
4	78	161-08001	HX. NUT 1/2"-13	STEEL	
4	77	166-32001	LOCK WASHER (SPR.) 1/2"	STEEL	
4	76	152-08021	CAP SCREW, HX. 4D	STEEL	1/2-13 x 1 1/2 LG.
1	75	4652-12E	UNION, 1 1/2"	BRASS	
4	74	4911-7	HX. NUT HEAVY 5/8-11	STEEL	
4	73	166-40001	LOCK WASHER SPRING	STEEL	5/8"
4	72	152-10109	CAP SCREW 3/8-11 x 1 1/2 LG.	STEEL	
1	71	6452-1	TEMP RELIEF VALVE	S.S.	(FUSIBLE PLUG)
4	70	4204-2	ELBOW 90, 1/2"	STEEL	
1	69	—	—	—	
1	68	4936-4	UNION 1/2"	M.I.	
1	67	4652-16E	UNION, 2"	BRASS	
3	66	4649-16E	ELBOW 90, 2"	BRASS	
6.3	65	445-10040	PIPE, 2"	BRASS	
1	64	—	—	—	
1	63	4648-16E	TEE, 2"	BRASS	
1	62	—	—	—	
1	61	—	—	—	
1	60	—	—	—	
1	59	6486-1	HOSE ASSEMBLY	BRASS	
1	58	—	—	—	
1	57	—	—	—	
1	56	—	—	—	
1	55	4968-19	REDUCER, 1 1/2 x 1"	STEEL	
17	53	4202-121	CLOSE NIPPLE, 1"	STEEL	
1	52	4771-424	BUSHING 1 1/2 x 1 1/2"	BRASS	
1	51	510-2147-1	SKID FABRICATION	STEEL	
1	50	510-1772-3C	HOSE ASSY. TWIN	—	1" x 1" x 100"
1	49	4771-429	BUSHING 2" x 1"	BRASS	
6	48	4202-25	CLOSE NIPPLE 1/2"	STEEL	
2	47	4771-109	BUSHING 3/4 x 1/4"	STEEL	
3.0	46	445-01072	PIPE, 1"	BRASS	
2	45	6366-1	REGULATOR W/PRESS GAUGE	ALUM	SET AT 120 PSI
2	44	4205-2	TEE, 1/2"	M.I.	
6.0	43	145-10076	PIPE, 1/2"	STEEL	
1	42	4439-73	CLOSE NIPPLE 1/2"	BRASS	
1	41	4771-142	BUSHING, 3" x 1 1/2"	M.I.	
1.0	40	145-10072	PIPE, 1 1/2"	STEEL	

REVISIONS		C 510-2120		REV E
EO NO	SYM	DESCRIPTION	DATE	APPROVAL
DRAWN <i>Quill</i>				
DATE 1-4-85				
CHK <i>[Signature]</i>				
DATE 1-11-85				
APPROVED _____ DATE _____				
DESIGN _____				
ENGR _____				
MFG _____				
SCALE _____ WT. _____				
CODE _____ SHEET 3 OF 4				
ROCKWOOD Systems Corporation 80 Second Street South Portland, Maine 04106				
TWIN AGENT SKID RTA				
1500/250 W/1500 LB. DRY CHEM				
TANK & 250 GAL. AFF. TANK				
NEXT ASSY. DR. USED TO MAKE _____				
REF. DWG. NO. _____				
C 510-2120				
REV E				

QTY	ITEM NO.	PART OR IDENTIFYING NO.	NOMENCLATURE OR DESCRIPTION	MATERIAL	SPECIFICATIONS OR REMARKS
2	21	105-542020	BALL VALVE 1/4"	—	NPT
1	13A	M802-662040	BALL VALVE 1/2"	BRASS	
1	13B	M802-662040	BALL VALVE 1/2"	BRASS	
2	39	4204-12	ELBOW 90, 1 1/2"	M.I.	
2	38	4439-121	CLOSE NIPPLE, 1"	BRASS	
5	37	4202-169	CLOSE NIPPLE 1 1/2"	STEEL	
1	36	4237-12	CROSS, 1 1/2"	M.I.	
1	35	4652-BE	UNION, 1"	BRASS	
10	34	110-3820-4	ST. LF. NITROGEN TANK	STEEL	
1	33	6345-6	HOSE ASSY, 1"	S.S.	
5	32	6176-1	GLAND NIPPLE (CGA 580)	BRASS	
5	31	6175-1	GLAND NUT (CGA 580)	BRASS	
1	30	6185-1	TWIN HOSE REEL	—	ELECTRIC REWIND
2	29	4205-B	TEE, 1"	M.I.	
4	28	4771-112	BUSHING, 1 x 1/2"	M.I.	
28.3	27	145-10073	PIPE, 1" SCH 40	STEEL	
1	26	—	—	—	
1	25	4439-184	FIFE NIPPLE, 1 1/2"	BRASS	
2	24	4205-4	TEE, 1/2"	M.I.	
1	23	4204-4	ELBOW 90, 1/2"	M.I.	
4.1	22	145-10074	PIPE, 1/2" SCH 40	STEEL	CUT TO SUIT
18	20	4202-73	CLOSE NIPPLE 1/2"	STEEL	
1	19	4771-124	BUSHING, 1 1/2 x 1/2"	M.I.	
5	18	4771-405	BUSHING 1/2 x 1/8"	BRASS	
1	16	—	—	—	
2	15B	6156-12	PRESSURE GAUGE	BRASS	2 1/2" DIA. 0-400# PRESS. RANGE 1/2" NPT
2	15A	6156-15	PRESSURE GAUGE	BRASS	2 1/2" DIA. 0-3000# PRESS. RANGE 1/2" NPT
1	13	M802-662040	BALL VALVE, 1/2"	BRASS	
2	12A	M802-662080	BALL VALVE, 1"	BRASS	
5	11A	510-1869-3	NITROGEN CYLINDER	—	SIZE 300, 2000 PSI @ 70°F W/QUICK REL. VALVE & ACT. DEV. SET AT 275 PSI
2	10A	508-016-10	RELIEF VALVE, R150 1/2"	—	
2	9A	M802-662080	BALL VALVE, 1"	BRASS	
1	8	—	—	—	
1	7B	M802-662080	BALL VALVE-1"	BRASS	
1	6B	509-0663-4	BALL VALVE, 1 1/2"	BRASS	PNEUMATICALLY ACTIVATED
1	6A	509-0663-4	BALL VALVE, 1 1/2"	BRASS	PNEUMATICALLY ACTIVATED
1	5	—	—	—	
2	4A	6129-2	REGULATOR, NITROGEN	—	400 PSI SAFETY SET PRESSURE SET OUTLET PRESSURE AT 240 PSI
2	3B	5457-8	CHECK VALVE, 1"	BRONZE	CONBRACO
1	2	510-1678-4	DUAL AGENT HAND LINE	—	1" x 1'
1	1B	510-1919-4	1500 LB. DRY CHEM. TANK	STEEL	40 1/2" I.D. HEMI-HEADS, 250 PSI
1	1A	510-1941-3	250 GAL. FOAM TANK	STEEL	48" I.D. HEMI-HEADS, 250 PSI

LIST OF MATERIAL OR PARTS LIST



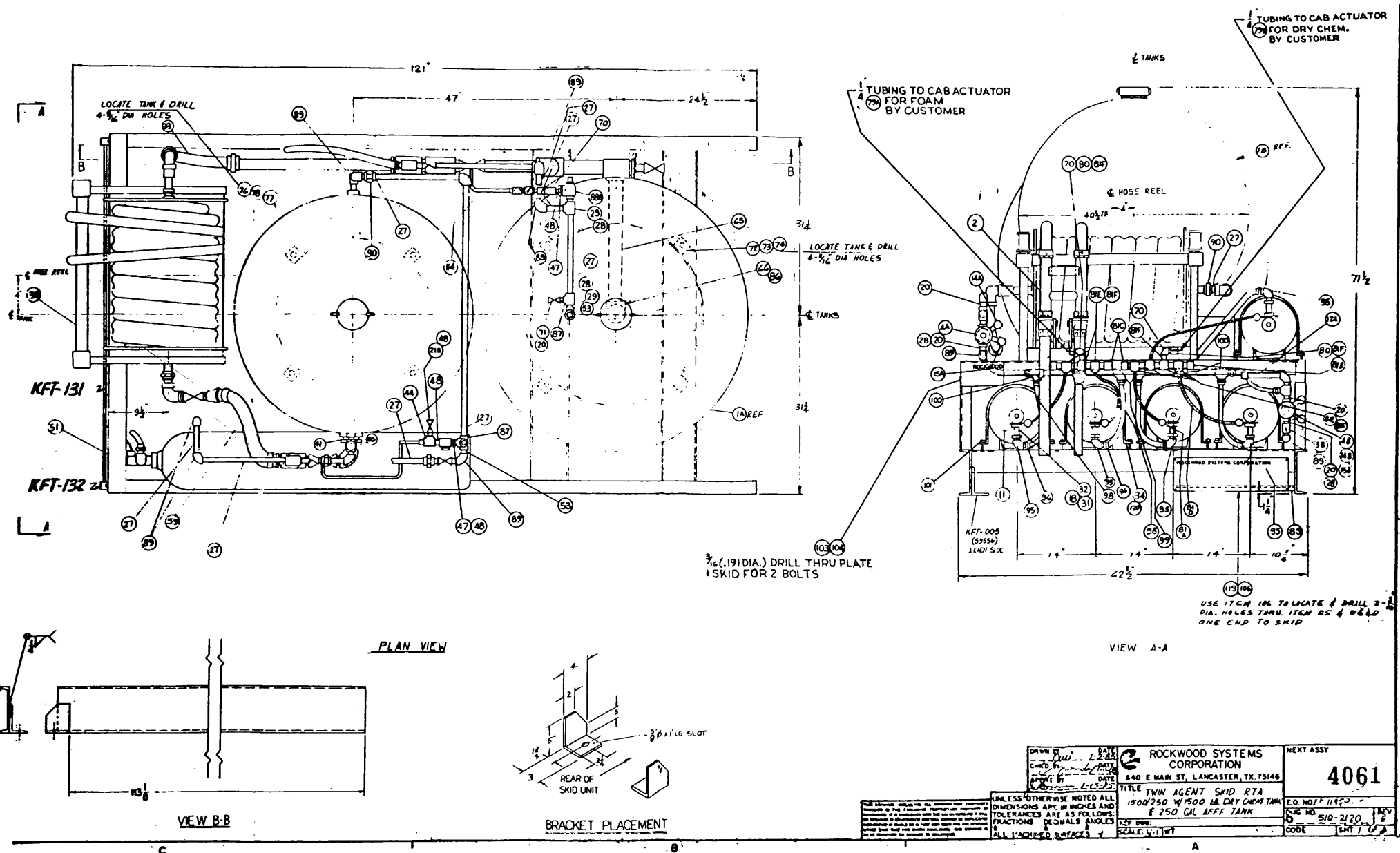

**OWNER'S  
INSTALLATION/  
OPERATION/  
SERVICE MANUAL**

**"A" Series  
Dynamic Inverters**

***DYNAMOTE***

DYNAMOTE CORPORATION 1200 W. Nickerson  
Seattle, WA 98119  
(206) 282-1000

***DYNAMO.***

SECTION I. DYAMOTE LIMITED WARRANTY

1.0 LIMITED WARRANTY

- 1.1 DYNAMOTE CORPORATION (Manufacturer) warrants, to the original user, that each DYNAMOTE Product is free from defects in materials and factor workmanship if, and only if, the following requirements are complied with:
- A. The produce is installed and checked out properly, according to all guidelines, instructions, and checkout procedures set forth in the product Installation/Operation/Service Manual, and
  - B. The installer records all checkout data required and completes, signs, and returns the warranty initiation card to the DYNAMOTE office within ten (10) days after installation.
- 1.2 Manufacturer's obligation under this warranty is limited to correcting without charge any part or parts of such products which shall be returned to its factory or one of its authorized service facilities, transportation charges prepaid, within one (1) year from first installation or within eighteen (18) months from date of manufacture, whichever comes first, provided examination discloses to Manufacturer's satisfaction that such parts ere originally defective. Correction of such defects by repair to, or supplying of replacements for defective parts, shall constitute fulfillment of all obligations to original user.
- 1.3 This warranty shall not apply to any of Manufacturer's products which must be replaced because of normal wear, which have been subject to misuse, negligence, or accident, or which shall have been repaired or altered outside of Manufacturer's factory, unless authorized by Manufacturer.
- 1.4 MANUFACTURER SHALL NOT BE LIABLE FOR ANY CLAIMS, LOSS, DAMAGE, OR EXPENSE WHATSOEVER RESULTING DIRECTLY OR INDIRECTLY FROM THE USE OF ITS PRODUCT OR FORM ANY OTHER CAUSE. SOME STATES DO NOT ALLOW THE EXCLUSION OR LIMITATION OF INCIDENTAL OR CONSEQUENTIAL DAMAGES, SO THESE LIMITATIONS MAY NOT APPLY TO YOU.
- 1.5 ANY AND ALL OTHER WARRANTIES, EXPRESS OR IMPLIED, ARISING BY LAW, COURSE OF DEALING, COURSE OF PERFORMANCE, USAGE OF TRADE OR OTHERWISE, INCLUDING BUT NOT LIMITED TO, IMPLIED WARRANTIES OF MERCHANTABILITY AND FITNESS FOR A PARTICULAR PURPOSE, ARE LIMITED IN DURATION TO A PERIOD OF ONE (1) YEAR AFTER FIRST INSTALLATION OR EIGHTEEN (18) MONTHS FROM DATE OF MANUFACTURE, WHICHEVER COMES FIRST. SOME STATES DO NOT ALLOW LIMITATIONS ON HOW LONG AN IMPLIED WARRANTY LASTS, SO THE ABOVE LIMITATIONS MAY NOT APPLY TO YOU. NO PERSON, AGENT, OR DEALER IS AUTHORIZED TO GIVE ANY WARRANTIES ON BEHALF OF MANUFACTURER OR TO ASSUME FOR MANUFACTURER ANY OTHER LIABILITY IN CONNECTION WITH ANY OF ITS PRODUCTS UNLESS MADE IN WRITING AND SIGNED BY AN OFFICER OF MANUFACTURER.

SPECIAL NOTICE TO PURCHASER  
REGARDING WARRANTY PROCEDURE

It is absolutely necessary that the requirements of Paragraph 1.1 above be complied with for warranty to be in effect. MAKE SURE THE INSTALLER HAS COMPLETED AND SIGNED YOUR PORTION OF THE WARRANTY INITIATION CARD, CERTIFYING THAT THOSE REQUIREMENTS HAVE BEEN COMPLIED WITH.

If any trouble occurs with this product during installation or before the warranty has expired, follow these instruction:

With model number and serial number available for reference, as well as all available installation test readings, dial the DYNAMOTE toll-free WATS line, 1-800-426-2838, and advise the receptionist that the call is regarding WARRANTY SERVICE ASSISTANCE.

©Copyright 1982, -DYNAMOTE CORPORATION

DYNAMOTE CORPORATION - 1200 W. Nickerson, Seattle, WA. 98119 - 206-282-1000

**SECTION II. GENERAL INFORMATION**  
**DYNAMIC INVERTERS**

**2.0 INTRODUCTION AND PRINCIPLE OF OPERATION:**

2.0.1 Your new DYNAMOTE Series A Inverter is designed to provide 120 volt, 60 Hz AC power from the DC (rectified AC) output of a standard 12 volt electrical system (12 volt alternator in a vehicle or boat). The inverter is compact, lightweight, and operates silently. It can be placed in any convenient location in the vehicle or boat. Inverters, when installed in a 12 volt electrical system according to these instructions, can safely operate all electric tools, lights, appliances, electronic and heavy motor loads up to their rated capacity. Models are available to provide continuous 120 volt power up to 60 amps.

2.0.2 The relationship of a Dynamic Inverter to the vehicle electrical system is illustrated by the two diagram below:

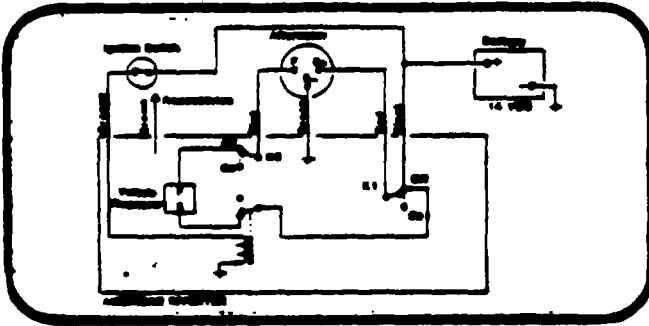

Figure 2.0.2A Inverter OFF

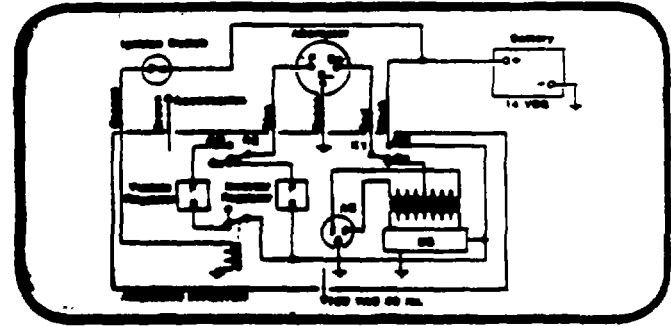

Figure 2.0.2B Inverter ON  
(Nominal alternator output voltage,  
Inverter ON, Series A - 60 volts)

As shown in Figure 2.0.2A, when the inverter is OFF, the alternator and battery function as in normal 12 volt operation. The only differences are 1) that Dynamote Regulator C33 controls the output of the alternator, and 2) that alternator output travels through the Dynamote harness on its way to the battery.

As shown in Figure 2.0.2B, when the inverter is ON, the system operates as follows:

- a. All output of the alternator is switched away from the battery and into the inverter;
- b. The alternator field is regulated by Dynamote Voltage Regulator CB1 inside the inverter. (See Note 1 below.)
- c. The Dynamote regulator controls alternator output at 45 volts (A40) or 60 volts (A30/60) rather than the standard 14.2 volts;
- d. The high voltage output enters the inverter transformer, the inverter produces 120 volt, 60 Hz power, and at the same time charges the vehicle battery and services the vehicle DC system at 14.2 volts. (See Note 2 below.)

NOTES: 1. When the inverter is energized, the Dynamic Voltage Regulator CB1 senses voltage at the secondary output of the inverter and regulates the alternator field with battery power to maintain 14.2 volts DC (rectified AC) at the BLACK wire of the inverter harness, which charges the battery.

2. The inverter transformer is wound so that at an average AC output of 120 volts, the vehicle battery is charged at 14.2

DYNAMOTE CORPORATION - 1200 W. Nickerson, Seattle, WA 98119 - 206-282-1000

2.0 INTRODUCTION AND PRINCIPLE OF OPERATION (continued)

volts DC. Both AC and DC voltages are regulated simultaneously by the Dynamote Voltage Regulator. If AC output voltage below or above 120 volts, battery charging voltage will be reduced or increased proportionately. For determining proper voltage settings after the inverter is installed, see Section 3.8, "Checkout Inverter Operation."

2.1 SPECIFICATIONS

1. DC (rectified AC) Input: 60 volts (A30 ).
2. Input Source: 12 volt alternator.
3. Input Electrical System: From 12 volt negative ground alternator systems only.
4. Input Voltage Regulation: Solid-state voltage regulator inside inverter.
5. Output: Simultaneous output of:
  - a. 120 volt AC  $\pm$  5%, 60 Hz  $\pm$  .1 and
  - b. 14.2 volt DC for vehicle system battery charging
6. Output Voltage Regulation: Solid-state voltage regulator inside inverter.
7. Output Frequency Regulation: Solid-state, crystal controlled oscillator inside inverter.
8. Output wave Form: Modified square wave with no limitations on operation of electronic or electromechanical loads. Filters are available for wave form modification to sine wave, if required.
9. Ambient Air Requirements: Full load capability at 120°F. ambient if properly vented. Output may be derated above 120 F.
10. Cooling Air Requirements: Exhaust air must be vented away from the ambient. Intake air must be true ambient, and must be the amounts shown in Figure 2.1.1A below for each model.
11. Miscellaneous: See following page.

2.1.1 INVERTER SPECIFICATIONS

Model Number	Watts, 120VAC Output	Amps, 120VAC Output	Surge Cap. AC Amps	Max. DC Charging H x W x D	Shipping Wt. Lbs.	Required Intake Cooling Air, CFM
A30-70B	3600	30	60	70 9 3/4"x14 1/4"x15"	70.	120

Figure 2.1.1A Inverter Specifications

2.2 PRODUCT CONFIGURATION

2.2.1 Chassis - Dynamic Inverters are housed in a durable aluminum chassis, with four shock absorbing rubber feet. Cooling air is drawn in through louvers in each side wall and exhausted out through the back panel. Tie down brackets are provided with hardware kit; they attach to the four heavy bolts at the bottom of the front and rear panels of the chassis.

- 2.2.2 Instrument Panel - Momentary START and STOP buttons, AC voltage indicator, and remote control receptacle are provided. Two 15 amp convenience receptacles are provided on the front panel. Each receptacle is separately fused. A control circuit fuse, commutation (input) fuses, and an "on-off" indicator light are also located on the front panel.
- 2.2.4 Hookup Harness - Once properly installed to the vehicle electrical system, harness MUST be checked and the results MUST be recorded on warranty initiation card. The 4-2600 Dynamic Installation Test Module plugs into the test receptacle on the front of the inverter and provides the readings necessary to checkout the installation and to record the information on the warranty card.
- 2.2.5 Chassis Configuration - Shown on figure 2.2.5B.

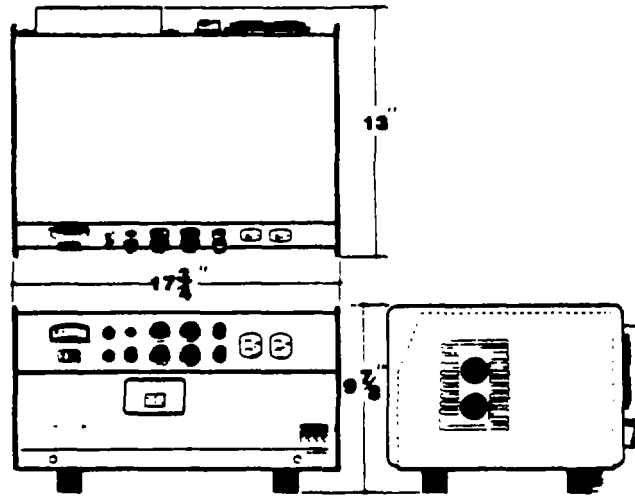

Figure 2.2.5B  
 A30 and MPA30 dimensions are:  
 H - 9 3/4"; W - 14h; D - 15"

- 2.2.6 Mounting Configuration - Diagram 2.2.6A shows the mounting dimensions for the A30 Series.

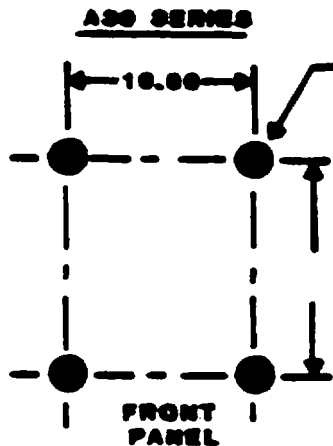

Figure 2.2.6A

- 2.2.7 Miscellaneous - Installation hardware, spare fuses, warranty statement and registration card, and instruction manual accompanies each new inverter. The manual should be kept with the inverter at all times.

### SECTION III. INSTALLATION INSTRUCTIONS

#### DYNAMOTE SERIES "A" DYNAMIC INVERTERS

FOR INSTALLATION ON VEHICLES AND BOATS WITH 12 VOLT NEGATIVE GROUND ELECTRICAL SYSTEMS ONLY.

#### 3.0 READ THE INSTRUCTIONS FIRST.

The Dynamote Dynamic Series "A" AC Power Inverter is a precision engineered and manufactured instrument capable of providing reliable AC electric power for thousands of hours. However, in order for the inverter to perform its job reliably, it is very important that each component of the system be installed carefully, and that each step be performed correctly. Therefore, before proceeding with the installation, it is suggested that you take a few minutes to familiarize yourself with the components of the system and how they are to operate when properly installed.

#### 3.0.1 IMPORTANT NOTE:

There are seven distinct steps which must be followed in sequence to assure proper installation and operation of the entire system. These steps are summarized below, and described in detail beginning on the next page.

- (1) Route harness to alternator.
- (2) Install automatic throttle, if used.
- (3) Attach harness to alternator.
- (4) Checkout alternator connections.
- (5) Checkout inverter.
- (6) Wire AC output.
- (7) Complete, sign, and mail warranty registration card.

#### 3.0.2 RECOMMENDED TOOLS AND EQUIPMENT FOR INVERTER INSTALLATION.

- (1) Socket wrench set (" or 3/8" drive) with 1/2", 3/8", 7/16", 1/2", and 3/4" socket, ratchet; and 6" extension.
- (2) 7" mechanic's screwdriver.
- (3) 1/2" and 7/16" open end wrenches.
- (4) V O M (volt-ohm-milliamp meter), #4 Fluke 8020A, Simpson 463, or equivalent; Dynamote 4-2600.
- (5) Wire crimpers and lineman's pliers.
- (6) Wire stripper.
- (7) Electrical tape and electrical putty.
- (8) Dynamote 4-2600, Installation Tester.

Figure 3.0.3A on the following page lists all the hardware items included with the various "A" Series inverters. Check and identify the various items as you unpack the shipping carton.

Figure 3.0.3A HARDWARE KIT

Part No.	Qty.	Description	Included With: A30
2283-00014	1	Harness - Input - Power	x
4283-00010	1	Harness - Control	x
	1	Field Grounding #16	
		White Wire (1')	x
4200-06400	2	Fuses, ABU 40	x
4200-02150	3	Fuses, AGC 15	x
4282-00006	2	HOLDERS, Spare Fuse	x
3056-11451	4	Brackets, Tie Down	x
4442-60920	2	Lugs, RB-257	x
4442-15200	2	Lugs, B-71	x
4442-14200	4	Lugs, B-87	x
4323-00417	1	Rubber Cap	x
4722-37008	1	i-20 x 3/8" Bolt	x
4520-27000	1	i-20 Kept Nut	x
4722-40008	4	#14 x 1" Screws	x
4442-16600	3	Lugs F-72	x
4-7211	1	Relay, High Amp. Bypass	Optional
4760-14000	5	Ty Raps	x

Figure 3.0.3A HARDWARE KIT CONTENTS

3.0.4 Start your installation with the first step and follow each step through in sequence to successful final testing. As it is completed, check off each step in the space provided adjacent to the step number of the test/warranty registration card.

DO NOT PROCEED TO ANOTHER STEP UNTIL ALL PREVIOUS STEPS HAVE BEEN SUCCESSFULLY COMPLETED.

3.2.0 ROUTE HARNESS TO ALTERNATOR

BURNING OR CHAFING THROUGH HARNESS INSULATION WILL DAMAGE THE INVERTER AND THE VEHICLE ELECTRICAL SYSTEMS. YOU SHOULD BE AWARE THAT THIS IS A COMMON INSTALLATION PROBLEM.

### 3.2.0 ROUTE HARNESS TO ALTERNATOR - Continued

Route the wiring harness to the alternator, using existing holes where possible. Use tie wraps and tape liberally to secure the harness wires so they cannot come in contact with the hot engine exhaust or other heat producing components. Grommets should be used to protect the wiring harness where it comes in contact with hard or sharp edges.

NOTE: Do not attach any wires to the inverter at this time.

3.3.2 The alternator must be installed correctly on the engine, according to the following general guidelines:

- (1) Alternator Pulley Alignment: The requirements of the alternator mechanical installation are several: (1) solid, vibration-free attachment of the mounting bracket to the engine, and of the alternator to the mounting bracket; (2) correct belt alignment; and (3) protection from road spray or marine water spray, and from engine exhaust heat. Hardened steel flat washers should be substituted for spring lock washers on bracket and alternator as mounting hardware. Flat washers tend to provide and retain greater surface tension.

Correct belt alignment is essential for maximum alternator and belt service life. The center line of all pulleys related to the alternator drive must be within 1/32" of true center; See Figure 3.3.2A.

Dual belts are recommended for heavy duty alternators. Best results are obtained if the belts wrap the alternator pulley 100° or more. Lesser wrap induces belt slippage, belt and alternator bearing wear; See Figure 3.3.2B.

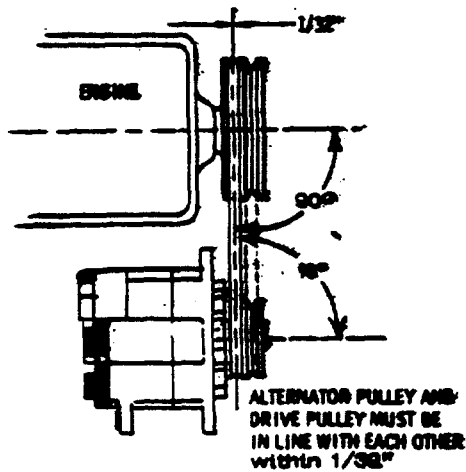

Figure 3.3.2A

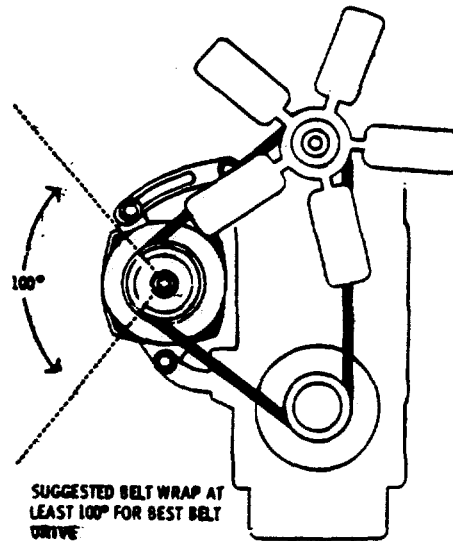

Figure 3.3.2B



### 3.4.0 INSTALL AUTOMATIC THROTTLE

An automatic throttle provides automatic increase in engine speed to a present RPM when the inverter is energized. It is designed for stationary use only, and should not be used while underway. IT MUST ALWAYS BE WIRED THROUGH THE NEUTRAL SAFETY SWITCH OF THE VEHICLE TRANSMISSION.

If the automatic throttle is used, refer now to automatic throttle instruction manual. NOTE: Brown wire from Dynamic Inverter Harness is to be attached to black wire from Autothrottle Harness.

### 3.5.0 ATTACH HARNESS TO ALTERNATOR

Installation of all Dynamic Inverters is exactly the same, electrically.

- (a) The harness for the larger capacity inverters includes three BLACK AWG #4 wires. Two of these are marked at the ends with RED and GREEN tape. If these wires are shortened, be sure to color-code the ends properly.
- (b) Instructions for the installation of the inverter harness begin with Section 3.5.1.

### 3.5.1 BASIC INSTALLATION STEPS

1. Switch battery disconnect located on console inside cab to "OFF".
2. Disconnect all wiring from the positive output (B+) terminal of the alternator.

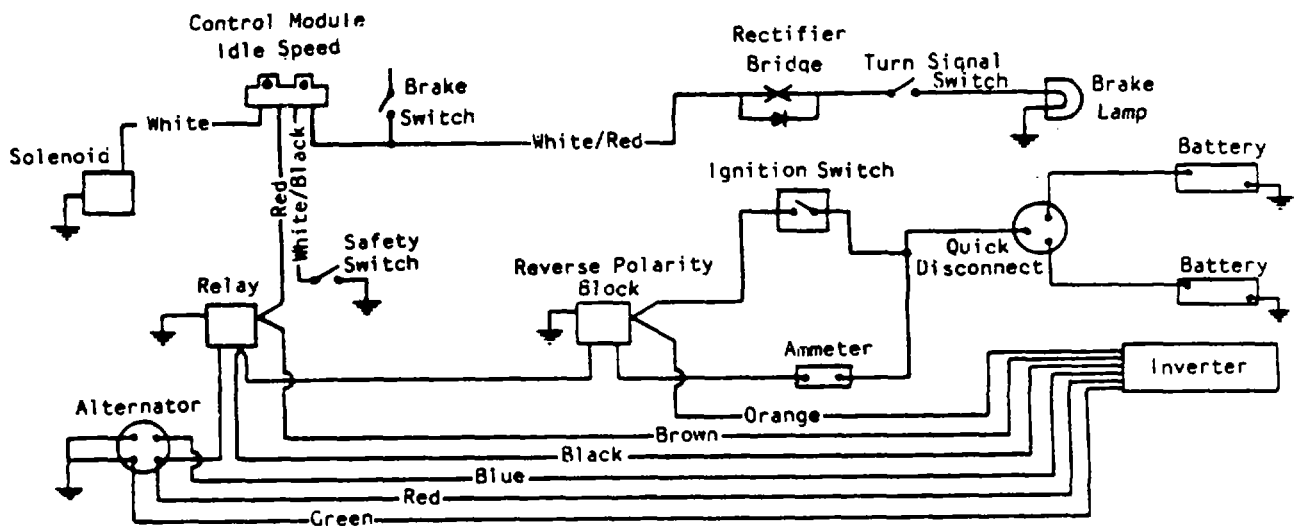

Figure 3.5.1A

### 3.5.1 **BASIC INSTALLATION STEPS - Continued**

#### 3. High Amperage Bypass Installation

- (a) Securely mount relay K3 as close to the alternator as is practical with large (5/16") studs down. (Mounting of this relay with the studs up or horizontal would result in improper operation of the relay.) Use the large # ¼ x3/4 self-tap screws in the hardware kit for this purpose.
  - (b) Connect the wires removed from the alternator positive output terminal in step 2, above, along with the BLACK wire from the Dynamote harness to one of the large (5/16") studs of Relay K3. This connection provides charging current to the vehicle battery system.
  - (c) Connect a length of #4 AWG wire from the other large (5/16") stud to the positive output terminal of the alternator.
  - (d) Connect a #16 or #18 AWG wire from the chassis of Relay K3 to ground.
  - (e) Connect the BROWN wire from the Dynamote harness to the small #10 stud of Relay K3.
4. Connect the RED wire from the Dynamote harness to the positive output (B+) terminal of the alternator. The ONLY other wire that can be attached to this terminal is the #4 AWG wire to the K3 Relay if that is installed.
  5. Connect the GREEN wire from the Dynamote harness to the negative ground (B-) terminal of the alternator. Leave any previously attached wires connected to this ground terminal.

NOTE: The B- terminal of the alternator and the negative (-) battery terminal must be securely grounded to the engine block.

6. Crimp the appropriate terminal in the hardware kit to the BLUE #16 Dynamote harness wire and attach to the Field (+) Terminal of the alternator. There should be no wire attached to the FIELD (+) terminal except the BLUE harness wire.
7. Check to see that the negative (-) Field Terminal on the alternator has been grounded to the negative (B-) terminal of the alternator. If not, use a piece of #16 AWG wire and the ring terminals provided in the hardware kit accomplish this.
8. Attach the ORANGE wire from the Dynamote harness to the #10 stud on the reverse polarity block which is connected to the ACC terminal on the ignition switch. Use ring terminals provided in the hardware kit.
9. Switch battery disconnect located on console inside cab to "BOTH".

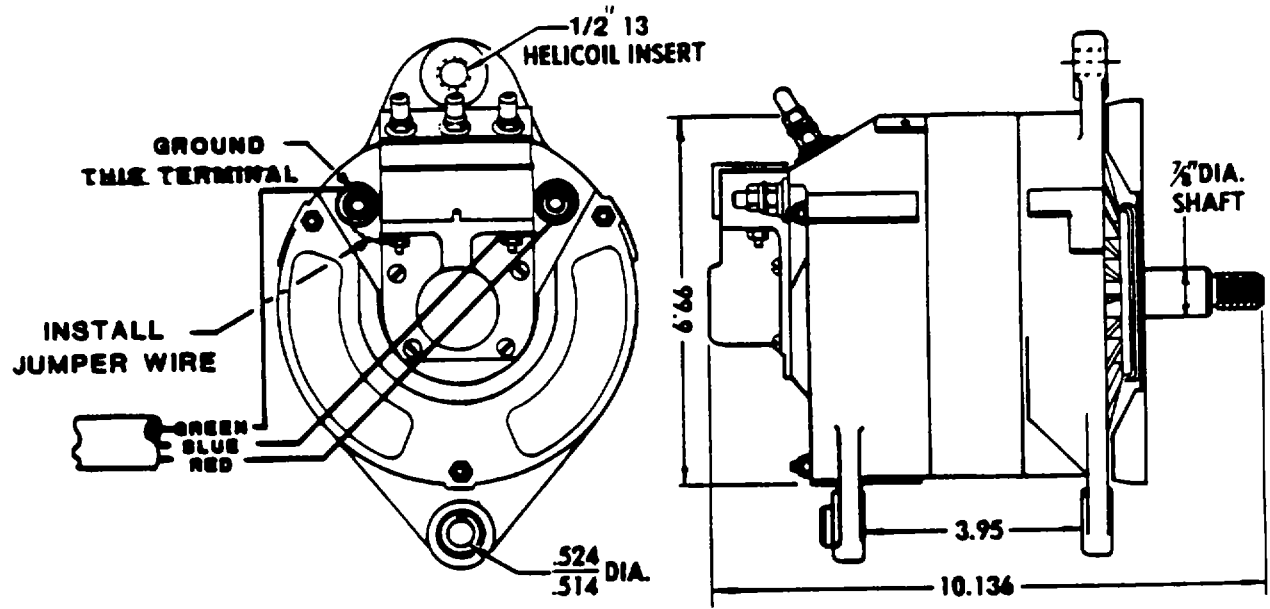

# 4000AA

Figure 3.5.4C DIAGRAMS OF LEECE NEVILLE 4000AA SERIES ALTERNATORS

### **3.6 CHECKOUT OF HARNESS INSTALLATION AND ALTERNATOR OUTPUT.**

THE RESULTS OF THIS CHECKOUT PROCEDURE MUST BE RECORDED ON THE WARRANTY INITIATION CARD AND RETURNED TO THE DYNAMOTE OFFICE. FAILURE TO DO SO WILL PREVENT THE INVERTER WARRANTY FROM BECOMING EFFECTIVE.

There are two ways to perform the Harness and Alternator Checkout Procedure:

- (1) Using the 4-2600 Dynamic Inverter Test Module. See Section 3.6.1.
- (2) Using a standard V O M (Volt Ohm Meter) with scales of 15VDC, 50VDC, and 100 VDC. (Fluke 8020A or Simpson 463 or equivalent.) See Section 3.6.2.

#### **3.6.1 CHECKOUT OF HARNESS INSTALLATION WITH DYNAMOTE 4-2600, DYNAMIC INVERTER TEST MODULE.**

If the Dynamote 4-2600 Dynamic Inverter Test Module is available, perform the following steps for checkout of harness installation. If the 4-2600 is not available, see Section 3.6.2.

1. Follow the instructions in Section 3 to install the inverter harness.
2. Put the test module sequence switch in the OFF position before connecting the module to the Dynamic Inverter. The vehicle ignition should also be in the OFF position.
3. Plug the six-pin test module into the Test Module Receptacle on the inverter front panel.

NOTE 1: DO NOT plug the test module into the control head receptacle on the inverter.

DO NOT plug the inverter Remote Control head plug into the Test Module Receptacle.

NOTE 2: If the BLACK (B+) lead is connected to a battery selector switch, the switch should be in the ON (that is, the B1, B2, or BOTH) position.

4. Follow the steps on the chart on the following pages, Figure 3.6.1A.

Figure 3.6.1A INSTALLATION AND INVERTER CHECKOUT USING 4-2600 DYNAMIC INVERTER TEST MODULE)

Switch Position	Terminal or Wire Being Read	Inverter Start Button Depressed	Vehicle Ignition ON	Proper Meter Reading	Remarks
1 (Red)	A+	No	No	11-13 VDC	If voltage reading is outside proper limits, recheck installation of inverter harness, RED and BLACK wires. Also check at K1 relay, Section 4.3.3 and K3 relay, Sec. 4.3.5.
2	Ignition (Orange)	No	No	0 VDC	If meter reads battery voltage, then the ORANGE wire is connected to a post which has battery voltage with the ignition ON or OFF. This will allow the battery to drain through the voltage regulator.
3	B+ (Black)	Yes No	No No	11-13 VDC 11-13VDC	If the reading with the Auxiliary Start Button depressed is 0, then the harness leads to the K3 relay should be switched.
4	A+ (Red)	Yes	No	0 VDC	If meter reads any voltage, check out K3 relay, Section 4.3.5.
5	F Out (Blue)	Yes	No	10-12 VDC	If voltage reading is outside proper limits; follow-Voltage Regulator Checkout Procedure, Section 4.3.7.
6	Ignition (Orange)	No	Yes	C0-12 VDC	Of meter reading is outside proper limits;, recheck wiring of ORANGE wire to be sure it is wired to a source of battery voltage with the ignition ON.
For Switch Positions 7 - 10, start the engine and run at approximately 1500-1800 RPM. Also turn ON vehicle headlights to put some load on the vehicle charging system.					
7	B+ (Black)	No	Yes	14.0-14.2 VDC	If meter reading is outside proper limits, follow procedure to check out and adjust Voltage Regulator CB3, Section 4.3.12.
8	A+ (Red)	No	Yes	14.0-14.2 VDC	If meter reading is outside proper limits, repeat test on Position 7.

3.6.1A INSTALLATION AND INVERTER CHECKOUT USING 4-2600 DYNAMIC INVERTER TEST MODULE (continued)

Switch Position	Terminal or Wire Being Read	Inverter Start Button Depressed	Vehicle Ignition ON	Proper Meter Reading	Remarks
9	B+ (Black)	Yes	Yes	14.0-14.2 VDC	If meter reading is outside proper limits, perform alternator check given for Switch Pos. 11(below), reading IMPORTANT NOTE: first.. Follow checkout procedure and adjust inverter Voltage Regulator CBI. NOTE: Be sure engine is running at or above the speed at which the voltage reading is at its maximum. This could be higher or lower than 1500 RPM, but will be the point at which increasing the RPM will no longer increase the voltage reading.
10	A+ (Red)	Yes	Yes	11-12 VDC (A30, A60) 8-9 VDC (A40)	This reading shows alternator output with inverter ON, divided by 5 that is, the actual voltage is 5 times the reading. If alternator voltage fails to come up to this level, perform alternator check in the next step.
<p>IMPORTANT NOTE: The test at Switch Position 11 is to check for a faulty alternator. Before moving the switch to Position 11, return the engine to an idle, turn the inverter OFF, and remove the commutation fuses on the inverter front panel. When the switch is in Position 11, the voltage regulator is taken out of the circuit and battery voltage is applied directly to the field of the alternator. This causes the voltage output of the alternator to increase directly with engine RPM. Rotate switch to Position 11, and slowly increase engine RPM until the voltmeter reads 20VDC. At this point the actual alternator voltage is 100VDC (5 times the meter reading). If the alternator will not come up to this voltage, then either the alternator or the installation is faulty. The alternator should be removed and sent to an alternator repair shop.</p>					
11	A+ (Red)	No	Yes	Increase to 20 VDC	Read IMPORTANT NOTE above. DO NOT MOVE SWITCH TO OR FROM POSITION 11 WHEN ENGINE IS ABOVE IDLE.

Figure 3.6.1A

INSTALLATION AND INVERTER CHECKOUT USING 4-2600 DYNAMIC INVERTER TEST MODULE

**3.6.1 CHECKOUT OF HARNESS INSTALLATION WITH DYNAMOTE 4-2600, DYNAMIC INVERTER TEST MODULE**  
(continued)

- 5. If procedures on Switch Position 1 - 10 check out, you may replace the covers on the inverter. Your electrical system is ready for operation.

Any problems found during this test procedure can be discussed with the DYNAMOTE Service Department by calling our toll-free number, 1-800-426-2838.

**3.6.2 CHECKOUT OF HARNESS INSTALLATION AND ALTERNATOR OPERATION WITHOUT 4-2600 DYNAMIC INVERTER TEST MODULE**

NOTE: FOR THIS TEST, DO NOT PUSH OR RELEASE START SWITCH WHEN ENGINE IS RUNNING ABOVE IDLE.

Perform the checkout with a V O M capable of reading 15VDC, 50VDC, and 100VDC (Simpson 463, Fluke 802A or equivalent).

Access to the terminal posts can be obtained either through the use of a Dynamic Test Strip plugged into the Test Receptacle on the inverter front panel, or by removing the inverter panels carefully and exposing the terminals inside the back of the inverter.

TO CHECKOUT THE HARNESS, FOLLOW THIS PROCEDURE: (Colors refer to wires attached to the indicated terminal posts.)

- 1. Disconnect the RED wire of throttle control module from the #10 stud of relay K3.
- 2. Remove warranty initiation card from Section 1 of the Instruction Manual. Record in pencil the readings from all the following steps.
- 3. Turn ignition OFF. Connect harness to inverter at this time.
- 4. Connect battery negative ground cable.
- 5.A. With ignition OFF and Dynamote Start Button ON, readings should be as follows:

Ground (GREEN) post to Battery + (BLACK) post	= 12-12.8V
Ground (GREEN) post to Alternator B+ (RED) post	= 0V
Ground (GREEN) post to F Out (BLUE) post	= 12-12.8V
Ground (GREEN) post to Ignition (ORANGE) post	= 0V
Ground (GREEN) post to Accessory (BROWN) post	= 12-12.8V

- B. With ignition ON, engine OFF, and inverter Start Button NOT depressed, readings should be as follows:

Ground (GREEN) post to F Out (BLUE) post	= 10-12.8V
Ground (GREEN) post to Ignition (ORANGE) post	= 10-12.8V

©Copyright 1981, DYNAMOTE CORP.

### 3.6.2 HARNES & ALTERNATOR CHECKOUT WITHOUT 4-2600 (continued)

#### Trouble Shooting Steps for Step 5.

- 1) If GREEN to BLACK is less than 12 volts DC, there could be a faulty ground condition (GREEN wire or battery ground strap). If properly grounded, the battery may be dead or defective. Return battery to a charged state before continuing. If battery is acceptable, the BLACK wire could have faulty connections.
- 2) If GREEN to RED is greater than zero without K3 Relay, the alternator is still connected directly to the battery. Check to be sure the Dynamote RED harness wire is the only one attached to the output terminal of the alternator.
- 3) If GREEN to RED is greater than zero with K3 Relay, the K3 Relay is incorrectly installed or not energizing. Refer to Section 3.5.1, Step 3.
- 4) If GREEN to ORANGE is larger than zero, ORANGE wire is incorrectly connected to the ignition switch.

— 6. Start engine and increase engine speed to about 1000 RPM (equivalent to engine speed at about 20 MPH). Voltages should read as follows:

Ground (GREEN) post to Battery + (BLACK) post	= 13.5-14.2V
Ground (GREEN-) post to Alternator B+ (RED) post-	=13.5-14.2V
Ground (GREEN) post to F Out (BLUE) post - variable up to 14.2V	
Ground (GREEN) post to Ignition (ORANGE) post	= 12.0-14.2V
Ground (GREEN) post to Accessory (BROWN) post	= 0V

#### Trouble Shooting Tips for Step 6.

- 1) If BLACK and RED are greater than 14.2VDC or less than 13.5VDC, adjust the vehicle voltage regulator CB3. If adjusting the CB3 doe\* not correct the DC voltage at BLACK, proceed to the applicable step following:
  - a) If BLACK and RED are less than 13.5VDC and BLUE is greater than 13.5VDC, check if BLACK voltage varies with the engine speed. If it does, either the pulley ratio is too low or the alternator is overloaded. Verify that BLUE is the only wire on the alternator positive FIELD terminal, and that the alternator negative FIELD terminal is grounded. If all wiring conditions are correct, then the alternator is faulty or the belts are slipping.
  - b) If BLACK and RED are greater than 14.2VDC and BLUE is greater than 12VDC, verify that BLUE is the only wire connected to FIELD positive terminal.
  - c) If BLACK and RED are less than 13.5VDC and BLUE is less than 100VDC, CB3 is defective and should be replaced.



### 3.6.2 HARNES & ALTERNATOR CHECKOUT WITHOUT 4-2600 Continued)

— 7. With engine still running at about 1000 RPM, remove commutation fuses on inverter, and push Dynamote Start Button. Voltage readings should be as follows:

Ground (GREEN) post to Battery + (BLACK) post	= 12-12.8VDC
Ground (GREEN) post to Alternator B+ (RED) post	= 15.0VDC or greater
Ground (GREEN) post to F Out (BLUE) post	= 12-12.8VDC
Ground (GREEN) post to Ignition (ORANGE) post	= 12-12.8VDC
Ground (GREEN) post to Accessory (BROWN) post	= 12-12.8VDC

#### Trouble Shooting Tips for Step 7.

- 1) If BLACK post voltage is above 12.8VDC, harness is wired improperly or K3 Relay is not functioning properly. Correct this defect before proceeding. This step assures proper disconnect of alternator output from vehicle battery when inverter is energized.
- 2) If RED post voltage reads below 15.0VDC, harness wiring is incorrect or alternator may be defective. Correct wiring defect, if any, at this time. Alternator defect, if any, will be determined in Step 8 below.

— 8. DO NOT PUSH OR RELEASE START SWITCH WHEN ENGINE IS ABOVE IDLE FOR THIS TEST

With commutation fuses removed and inverter Start Button depressed as in Step 7 above, slowly increase engine speed. Voltage from GREEN post to RED post should increase to about 100VDC at or below 2500 engine RPM. Do not increase engine speed in excess of 100VDC reading, and maintain this condition only long enough to check voltage output. This step assures that alternator diodes are satisfactory and that the alternator can provide the voltage necessary for proper operation of the inverter. Readings should be as follows:

Ground (GREEN). post to Battery + (BLACK) post	= 12-12.8VDC
Ground (GREEN) post to Alternator B+ (RED) post	= Up to 100VDC
Ground (GREEN) post to F Out (BLUE) post	= 12- 12.8VDC
Ground (GREEN) post to Ignition (ORANGE) post	= 12-12.8VDC
Ground (GREEN) post to Accessory (BROWN) post	= 12-12.8VDC

NOTE: Failure to obtain the specified reading is an indication of improper wiring or a defective alternator. If voltage is above 15VDC at idle but does not increase to 100VDC at higher engine speeds, the alternator is defective, usually caused by open or shorted diodes. The remedy is to replace the faulty alternator diode(s). Most alternators have six diodes, three with forward polarity and three with reverse polarity. It is best to replace a complete set of three diodes when replac-any. Use 200 PIV diodes available from an auto electr or electronic parts supply house.

Refer to alternator manufacturer's service manual for details of checking and re- pairing alternator diodes.

### 3.6.2 HARNESS & ALTERNATOR CHECKOUT WITHOUT 4-2600 (continued)

-9. Now compare your readings with the following summary, given in Figure 3.6.2A

Read Voltage from: Condition	BLACK to GREEN	RED to GREEN	BLUE to GREEN	ORANGE to GREEN	BROWN to GREEN
Ignition OFF, Inverter Start Button pushed	12.0 to 12.8	0	10.0 to 14.0	0	12.0 to 12.8
Ignition OFF, no other action taken	12.0 to 12.8	12.0 to 12.8	0	0	0
Engine ON at 1000 RPM	13.5	13.5	Variable to 11.0 (13.5- 14.2)	(13.5- 14.2)	0
Engine ON at idle, Inverter Start Button pushed	12.0 to 12.8	15.0 or more	10.0 to 12.8	10.0 to 12.8	12.0 to 12.8
Engine ON, 1000 RPM up to 2500 RPM; Commutation Fuses removed, Inverter Start Button pushed	12.0 to 12.8	up to 100 VDC	12.0 to 12.8	10.0 to 12.8	12.0 to 12.8

Figure 3.6.2A SUMMARY OF TEST VOLTAGE READINGS

-10. Reinstall commutation fuse.

If all steps check out correctly, CONGRATULATIONS. The harness is properly attached to the alternator system and the alternator is capable of operating the inverter properly. BE SURE ALL CHECKOUT DATA IS RECORDED ON THE WARRANTY INITIATION CARD BEFORE PROCEEDING.

DYNAMOTE CORPORATION, 1200 W. Nickerson, Seattle, WA 98119 - 206-282-1000

### **3.7.0 CHECKOUT INVERTER OPERATION**

(Put Auto Manual Switch in Manual position. See 2.2.2.1)

3.7.1 Disengage Automatic Throttle by disconnecting the RED wire of throttle control module from the #10 stud of relay K3.

3.7.2 Check battery charging voltage with inverter OFF. Turn inverter OFF, and increase engine speed to about 1,000 RPM (medium fast idle). Check battery voltage. It should read 13.5 to 14.2 volts DC. If it does not, adjust CB3.

3.7.3 Start Inverter. Start engine, and manually increase engine speed to approximately 1,500 RPM (equivalent to engine speed at about 30 MPH). Depress the start button. The inverter should START, that is, you should hear the inverter "hum", the indicator light should turn ON, the cooling fan should be exhausting air through the fan shroud in the rear chassis panel, and the voltmeter should register AC voltage up to 130 volts. If the inverter does not START, refer to Troubleshooting Section 4.

3.7.4 Check for proper charging voltage with Inverter ON. With vehicle engine still running at approximately 1,500 RPM, and with inverter ON, allow 3-5 minutes of inverter operation for charging voltage to stabilize. With inverter still ON, using an accurate DC voltmeter, check voltage on vehicle system battery. It should read 14.0-14.2 volts DC. If it does not, adjust CB1. If this does not correct the problem, refer to the Troubleshooting Section 4.

3.7.5 Check AC voltage stability under load. With inverter still operating at 120 volts output, apply the normal AC load you intend to operate on the inverter. If actual load is not available, simulate the actual load with an equivalent wattage and type of load (resistive or inductive).

If AC load does not operate properly, or if inverter output voltage drops more than 10 volts, or if inverter shuts off when AC load is applied, remove AC load, turn inverter OFF and refer to Troubleshooting Section 4.

3.7.6 Adjust Automatic Throttle. Reconnect the RED wire of the throttle control module to the #10 stud of relay K3. Now, START the inverter. The autothrottle should energize when the inverter starts. Adjust turnbuckle on the autothrottle linkage to minimum engine speed that will maintain usable AC voltage when inverter is operating under normally expected AC load.

**3.8.2 Models A30-70D**

- A. In these units, AC output is a standard two-wire output, with a hot and neutral lead. 'Only the "hot" lead (AC 1) cannot be grounded.
- B. The AC receptacles can be used up to their fused capacity of 15 amps per receptacle for all models.
- C. If permanent connection of inverter is desired, follow these directions:  
  
Connect AC leads to external AC junction box, using circuit breaker or fuses for each separate circuit. Only the "hot" (BLACK) wire should not be grounded.

**3.9 COMPLETE, SIGN AND MAIL WARRANTY INITIATION CARD**

The final step is to initiate the inverter warranty. Proper installation is not complete until warranty is properly initiated, as follows:

- A. Fill in the final customer's name and address and vehicle data.
- B. Enter all checkout data from the harness and alternator checkout procedures in Section 6.
- C. Sign your name and the company name and address, certifying that the installation was properly completed, and enter the date of installation.
- D. Fill in and sign the Owner's Certificate of Warranty Initiation card from the first section of the manual.
- E. Mail the stamped, self-addressed warranty initiation card to DYNAMOTE CORPORATION.

**DYNAMOTE CORPORATION, 1200 W. Nickerson, Seattle, WA 98119 - 206-282-1000**

**SECTION IV SERVICE AND TROUBLESHOOTING**  
**INSTRUCTIONS FOR DYNAMOTE SERIES "A" DYNAMIC INVERTERS**

**4.1.0 General Information. PLEASE READ CAREFULLY.**

The only reason to be at this point in the manual is that the inverter and/or vehicle charging system are not working properly.

If this is a new installation and has not yet been in service, be sure to go through the checkout procedures in Section 3.6 before proceeding further. If you have completed the checkout procedure in Sand the inverter still does not work, continue with this section.

If the inverter has been in service and working properly prior to this failure, and if the installation has not been tampered with, such as for servicing the vehicle in some way, then the likely cause of failure is in the inverter and can be found through the troubleshooting procedure.

It is easiest to troubleshoot the inverter while it is installed in the vehicle or boat, as the electrical system provides a power source to check out all inverter functions. Another alternative is a test bench which includes alternator and battery, and simulates a vehicle or boat electrical system.

If neither of these is available, many of the troubleshooting tests can be performed by connecting the inverter harness to a 12 volt battery as follows:

GREEN to battery Negative (-)  
Black to Battery Positive (+)  
ORANGE to Battery Positive (+)  
Other wires not connected

The Troubleshooting guide is to be found in section 4.3.0.

**4.2.0 INVERTER REMOVAL FROM VEHICLE SYSTEM FOR SERVICING.**

**NOTE: DO NOT REMOVE INVERTER UNTIL AFTER THE TROUBLESHOOTING PROCEDURE HAS BEEN COMPLETED AND IT IS DETERMINED THAT THE INVERTER MUST BE REMOVED FOR SERVICE.**

1. Remove inverter mounting screws.
2. Turn inverter to gain access to rear panel. Carefully remove rear panel and disconnect harness wires from studs in the inverter. (Mark wires and studs for easy reinstallation.) Loosen harness clamps-on top of inverter and remove harness wires.
3. Remove inverter from vehicle.
4. Tape each ring terminal individually and secure so that terminals do not touch body.

#### **4.2.0 INVERTER REMOVAL FOR VEHICLE SYSTEM FOR SERVICING - Continued**



Batteries will not charge while inverter is disconnected. Operation of vehicle while inverter is disconnected will result in draining of batteries.

#### **4.3.0 TROUBLESHOOTING GUIDE FOR DYNAMOTE SERIES "A" DYNAMIC INVERTERS**

Introduction: This troubleshooting section takes the most common symptoms of inverter failure and suggests probable causes and solutions. The objective is to provide relatively simple solutions for 90% of the problems that will be encountered. Only the simplest of tools and instruments are required: a Volt-Ohm Meter which reads to 100 VDC, socket wrenches, and a screw driver. A 10" extension on the socket wrench will be helpful if the cathode leads to the SCRs must be removed.

The remaining 10% of the possible problems are often intermittent or less obvious and require more sophisticated instruments and technical expertise to solve. This kind of capability can be found at the DYNAMOTE factory and major warranty and repair centers about the country. If the problem cannot be solved using this troubleshooting guide with approximately 1 hour, then help should be sought from one of these facilities.

The inverter electrical schematics, included in Section 4.4.0 will be essential in understanding-the checkout procedures, and the inverter wiring diagrams in Section 4.5.0 will be-useful in locating parts and terminal points. The parts list is also located in Section 4.5.0 and gives Dynamote part numbers for all referenced components for use in ordering replacement parts.

##### **4.3.1 USE OF THE TROUBLESHOOTING GUIDE**

If the symptom of failure is known, proceed directly to that symptom in the troubleshooting chart, Section 4.3.2. If the symptom is not known, begin the troubleshooting process by going to symptom #1 in the troubleshooting chart, pushing the START button and progressing through the chart steps until the applicable symptom is found.

##### **4.3.2 TROUBLESHOOTING CHART**

The alternator should be turning approximately 4000 RPM, or about 1500 engine RPM for performing tests to determine the applicable symptom.

If the inverter is connected only to a battery and not to an alternator, the test at symptom #3 can be performed as well as the checkout procedures for the voltage regulators, ocillator board, diodes, SCRs, and relays K1, K2 and K3.

**Section 4.3.2 TROUBLESHOOTING CHART**

No.	SYMPTOM	PROBABLE CAUSE	SOLUTION
1	Start button pushed, no response	Blown control fuse  Inoperative K2 Relay.	Check control fuse F5 on inverter front panel. If there is no control fuse on the inverter, go on to the next probable cause.  Follow procedure to check out K2 Relay, see Section 4.3.4.
2	Start button pushed, relays will not remain energized but chatter on and off	Inverter harness improperly installed with RED wire attached to battery and BLACK wire attached to alternator output.	Install RED and BLACK wires properly according to installation instructions.
3	Start button pushed, relays energize with an audible click, but inverter will not start (Fan does not turn.)  (ENGINE MUST BE RUNNING APPROXIMATELY 1500 RPM FOR THIS AND REMAINING TROUBLESHOOTING STEPS)	Blown commutation fuses fuses, Section 4.3.6. Inoperative K3 Relay  Inverter voltage regulator inoperative or fuse is blown  Shorted SCR.  Oscillator circuit board inoperative.  Diode D5.or D6 open.  Diode D3 and/or D4 shorted.	Follow procedure to check commutation  Follow procedure to check K3 Relay, Section 4.3.5.  Follow procedure to checkout voltage regulator, Section 4.3.7.  Follow procedure to checkout SCRs, Section 4.3.9.  Follow procedure to checkout oscillator board, Section 4.3.8.  Follow procedure to checkout Diodes D5 and D6, Section 4.3.10.  Follow procedure to checkout Diodes D3 and D4, Section 4.3.10.
4	Start button pushed, inverter turns on, (fan turns), but stops when start button is released	Diode D2 is open	Replace Diode D2.

No.	SYMPTOM	PROBABLE CAUSE	SOLUTION
5	Low output voltage, AC and DC	Loose alternator belts Alternator RPM too slow  K3 Relay inoperative Inverter voltage regulator out of adjustment.  Shorted or open diodes in the alternator	Tighten belts by adjusting alternator bracket. Run engine at faster speed and see if output voltage goes up.  Follow procedure to checkout K3 Relay, Section 4.3.5. Adjust voltage regulator.  Follow alternator diode test procedure, Section 4.3.11.
6	Inverter will not turn off, high output voltage, AC and DC.	Inverter voltage regulator inoperative or shorted.	Replace inverter voltage regulator, PCB1.
7	Inverter will not turn off, output voltage normal	Inverter voltage regulator inoperative K2 Relay points 3 and 9 not disengaging	Follow procedure for voltage regulator checkout, Section 4.3.7. Follow procedure for K2 Relay checkout, Section 4.3.4.
8	Inverter turns on, but will not carry AC load	Blocking Diode D5 and/or D6 shorted	Follow procedure for Diode D5 and D6 checkout, Section 4.3.10.
9	High AC output voltage, low or normal DC output voltage.	Diodes D3 and/or D4 open	Check Diodes D3 and D4, according to checkout procedure, Section 4.3.10.
10	High DC output voltage, low AC output voltage	Faulty K3 Relay	Follow procedure to checkout K3 Relay, Section 4.3.5.
11	Improper or no charging with inverter off, proper operation with inverter on	Faulty Vehicle Voltage Regulator, PCB3 Faulty K2 Relay	Checkout Vehicle Voltage Regulator according to procedure in Section 4.3.12 Follow procedure to checkout K2 Relay, Section 4.3.4.



#### **4.3.2 TROUBLE SHOOTING CHART (continued)**

##### **MOST LIKELY FAILURES**

Based on our experience at DYNAMOTE, the following, in order of descending frequency, are the most likely causes of inverter malfunction. In each case, there is a procedure to check it out.

1. K3 Relay
2. Blown Commutation Fuses
3. Shorted SCRs.
4. Inverter Voltage Regulator Board - no output.
5. Inverter Oscillator Board.

#### **4.3.3 K1 RELAY CHECKOUT PROCEDURE**

**Tools Required:** Ohm Meter and Voltmeter with 0-15VDC scale, 7/16" socket or open end wrench, screwdriver.

- 1) Open the inverter by removing the front, top and back panel fasteners. Carefully lay the front and back panels down and remove the top panel.
- 2) The engine and ignition should be OFF for the procedure.
- 3) Locate the K1 Relay, the larger cylindrical silver solenoid contactor on the right side of the inverter near the rear.
- 4) Depress the START button and there should be an audible click if the relay is operating.
- 5) With the Ohm Meter, check the resistance across the two large terminals at the top of the relay. WITHOUT depressing the START button the meter should read 100K Ohms to infinity, ( $\infty$ ).

WITH the START button depressed, the meter should read less than 5 Ohms. If the K1 Relay does not pass all of these tests, it should be replaced.

#### **4.3.4 K2 CONTROL RELAY CHECKOUT PROCEDURE**

**Tools Required:** Voltmeter with 0-15VDC scale, 7/16" socket or open end wrench, screwdriver.

- 1) If there is a control fuse on the inverter front panel, check it first.
- 2) Open the inverter by removing the front, top, and back panel fasteners. Carefully lay the front and back panels down and remove the top panel.
- 3) The engine and ignition should be OFF for this test.

**DYNAMOTE CORPORATION, 1200 W. Nickerson, Seattle, WA 98119 - 206-282-1000**

#### 4.3.4 **K2 RELAY CKECKOUT PROCEDURE (continued)**

- 4) Locate the K2 Relay. It is approximately 1"x1"x3", encased in clear plastic and located on the bottom left side of the inverter.
- 5) Depress and release the start button and visually confirm that the relay contacts are moving. If the contacts do not move, the relay should be replaced.
- 6) With the START button depressed, check the voltage from the ACC terminal at the rear of the inverter to GROUND. It should read 10 VDC or higher. If not, the relay should be replaced.
- 7) With the START Button depressed, check the voltage from the F Out terminal at the rear of the inverter to GROUND. It should read 10VDC or higher. If there is no voltage at the F Out terminal, and if the Voltage Regulator has checked good, then replace the K2 Relay.

#### 4.3.5 **K3 RELAY CHECKOUT PROCEDURE**

**Tools Required:** Volt Ohm Meter with 0-15VDC scale, screwdriver, 12" jumper wire.

- 1) The K3 Relay is the high amperage bypass relay and is a cylindrical silver solenoid contactor. It is installed either in the 4-2500 Dynamic Installation Kit or independently near the alternator under the hood. It can be found by following the wiring from the POSITIVE (+) terminal of the alternator.
- 2) The engine and ignition should be OFF for this test.
- 3) The small terminals on the relay are the coil terminals and the large terminals are the contacts.
- 4) Check the voltage from the positive to the negative coil terminal of the relay. With the inverter START button depressed, there should be an audible click and the voltage should be 10VDC or higher. Without the START button depressed, the voltage should be 0.

If these conditions are present, go on to Step 5.

If the voltage is 0 with the START button depressed, carefully check the wiring to the positive relay coil terminal (the one that is not grounded). This should come from the ACC terminal in the rear of the inverter.

If the wiring is correct, then go through the K2 Relay checkout procedure to be sure that there is voltage at the ACC terminal when the START button is depressed.

- 5) Check the voltage from the relay contact that is wired to the alternator POSITIVE (+) terminal to GROUND. Without the START button depressed, the voltage should be 10VDC or higher.

**DYNAMOTE CORPORATION, 1200 W. Nickerson. Seattle, WA 98119 - 206-282-1000**

#### **4.3.5 K3 RELAY CHECKOUT PROCEDURE (continued)**

With the START button depressed, the voltage should read 0.

Otherwise, replace the K3 Relay.

#### **4.3.6 COMMUTATION FUSE CHECKOUT PROCEDURE**

**Tools Required:** Ohm Meter.

- 1) Commutation fuses are in the larger fuseholders on the front panel of the inverter. There are two commutation fuses on A30s, and four commutation fuses on A40s and A60s.
- 2) Remove the commutation fuses. They must be checked with an Ohm Meter, as they are solid fuses and visual inspection will not determine if they are good.
- 3) Check the fuses with the Ohm Meter by placing a probe at each end. If there is no resistance, the fuse is good. If there is high resistance, the fuse is blown.
- 4) If the fuses are blown, be sure to replace them with the same value fuses.
- 5) Recheck commutation fuses after new installation.

#### **4.3.7 DYNAMIC INVERTER VOLTAGE REGULATOR PCB1 CHECKOUT PROCEDURE**

**Tools Required:** Voltmeter with 0-15VDC scale, 7/16" socket or open end wrench, screwdriver.

- 1) Open inverter by removing the front and top panel fastener. Carefully lay the front panel down on its face and remove the top panel.
- 2) Locate the inverter voltage regulator CB1 on the left side of the inverter. It is the forwardmost of the two circuit boards, and there are five wires attached to the board, or to a connector that is plugged into the board.
- 3) The engine and ignition are OFF for this test.
- 4) If the voltage regulator has a fuse mounted on the circuit board, check the fuse first.
- 5) With the inverter START button depressed, check the voltage from the BLUE wire on the voltage regulator circuit board to ground. Voltage should read 10 volts or more. If there is no voltage, the voltage regulator has failed in the open position and should be replaced.
- 6) If voltage at the BLUE wire is 10 volts or more, depress the inverter START button again and check the voltage from the F OUT terminal inside the rear of the inverter to GROUND. If the voltage at this terminal is not the same as the voltage at the BLUE wire on the voltage regulator, then the K2 Relay is faulty and should be replaced.

<sup>c</sup> Copyright 1981, DYNAMOTE CORP.

**4.3.8 OSCILLATOR CIRCUIT BOARD CHECKOUT PROCEDURE**

**Tools Required:** Voltmeter with 0-15VDC scale, 7/16" socket wrench or open end wrench, screwdriver.

- 1) Open inverter by removing the front and top panel fasteners. Carefully lay the front panel down on its face and remove the top panel.
- 2) The engine and ignition should be OFF for this test.
- 3) Locate the SCR gate leads. These are the small white leads to the SCRs which have a plastic connector in the lead. Separate this lead by disconnecting the plastic connector.
- 4) With the START button depressed, read the voltage to GROUND from each gate lead connector on the part of the gate lead which is connected to the Oscillator Circuit Board. The voltage should be between 2VDC and 7VDC, and should be equal  $\pm 3$ VDC for the two leads. If it is not, the oscillator board should be replaced.

**4.3.9 SCR CHECKOUT PROCEDURE**

**Tools Required:** Ohm Meter or Continuity Tester, 7/16" socket wrench with extender, 3/4" socket wrench with extender (A40 and A60 only), screwdriver.

- 1) Prior to checking out the SCRs, be sure that the commutation fuses are good, by following the commutation fuse checkout procedure.
- 2) Open inverter by removing the front and top panel fasteners. Carefully lay the front panel down on its face and remove the top panel.
- 3) The engine and inverter are OFF for this test.
- 4) An SCR (Silicon Controlled Rectifier) is a semiconductor device which will not conduct electricity in either direction unless the GATE is impulsed to turn on the SCR. When the GATE is impulsed, turn the SCR ON, the SCR will conduct from ANODE to CATHODE only. The purpose of this test is to determine if the SCR will conduct (i.e., show low resistance) without the GATE being turned on. If so, the SCR is shorted and should be replaced.

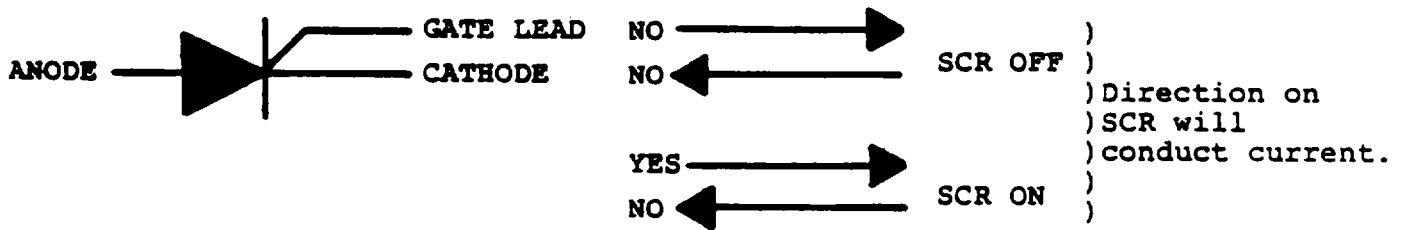

DYNAMOTE CORPORATION, 1200 W. Nickerson, Seattle, WA 98119 - 206-282-1000

#### 4.3.9 SCR CHECKOUT PROCEDURE (continued)

- 5) Remove SCR cathode (ground) leads from ground. These are RED #8 wires for A40/A60, and GREEN wires for an A30, which are attached to the bottom of the inverter with a bolt and 7/16" nut. The SCR does not have to be removed from heat sink for this test. The heat sink and anode are at the same potential.
- 6) Check resistance across SCR with positive (+) lead. from Ohm Meter on heat sink, and negative (-) lead on the cathode which was removed from ground stud. (See illustration.) If resistance reading is less than 1000 Ohms, the SCR is shorted and should be replaced. A resistance reading of 100, 000 Ohms to infinity ( $\infty$ ) indicates that the SCR is not shorted.

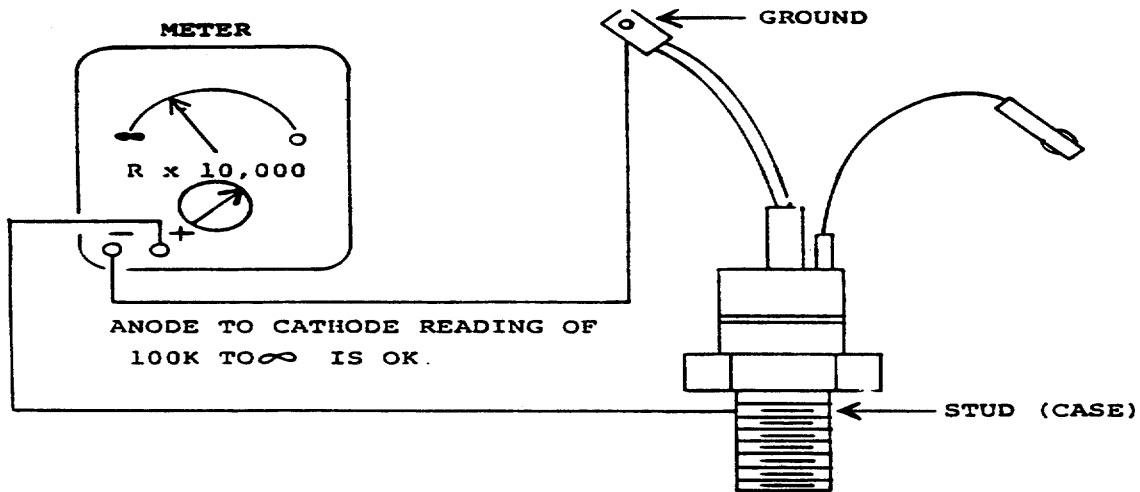

**NOTE: BE SURE EITHER STUD OR GROUND WIRE OF SCR IS REMOVED BEFORE CHECKING SCR.**

- 7) To replace the SCR, do the following:
  - a) If the inverter has one-inch holes in the slotted area behind the heat sink, pop the plastic plugs out of these holes from the inside with a screwdriver. If the inverter does not have holes in the slotted or louvered area behind the heat sink, then the heat sink must be removed by removing the four screws at the corners.
  - b) Disconnect the small connector in the SCR gate lead.
  - c) Remove the SCR, using the 7/16" socket if it is an A30, or the 3/4" socket for an A40 or A60, leaving as much of the white thermal compound on the heat sink as possible.

<sup>c</sup> Copyright 1981, DYNAMOTE CORP.4092

#### 4.3.9 SCR CHECKOUT PROCEDURE (continued)

- d) Install the new SCR, making sure that the nut is on very tight.
- e) Reconnect the Cathode (GROUND) lead.
- f) Reconnect the gate lead.

#### 4.3.10 DIODE CHECKOUT PROCEDURE

**Tools Required:** Ohm Meter or Continuity Tester, 7/16" socket wrench or open end wrench, screwdriver.

- 1) Open inverter by removing the front and top panel fasteners. Carefully lay the front panel down on its face and remove the top panel.
- 2) A DIODE (Rectifier) is a semiconductor device which functions as an electrical one-way street.

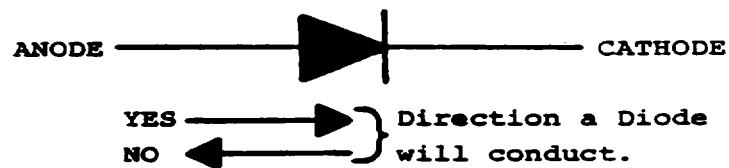

For stud-mounted diodes with normal or standard polarity, the stud is the CATHODE, and the tab or flag is the ANODE. See diagram below.

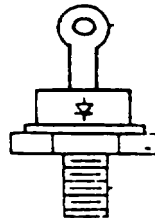

For stud-mounted diodes with reverse polarity, the stud is the ANODE and the flag or tab is the CATHODE. See diagram below.

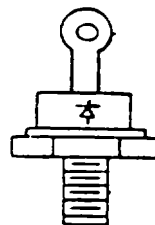

DYNAMOTE CORPORATION, 1200 W Nickerson, Seattle, WA 98119 - 206-282-1000

#### 4.3.10 DIODE CHECKOUT PROCEDURE (continued)

A diode which is not stud-mounted, but rather has axial leads, conducts in the direction the band on the diode indicating the CATHODE end, the end opposite indicating the ANODE.



Following is the polarity of the diodes in the Dynamic Inverters:

<u>Diode</u>	<u>Polarity</u>
D1	Standard
D2	Axial Leads
D3, D4	Reverse
D5, D6	Standard
D7, D8	Standard
D9, D10	Axial Leads

- 3) The diodes can be located using the wiring diagram, Figures 4.5.OA to F. Not all models have all ten diodes.
- 4) Diodes should be removed from the heat sink or chassis before testing. Figure 4.3.IOA on the following page gives the proper Ohm Meter readings.

© Copyright 1981, DYNAMOTE CORP.

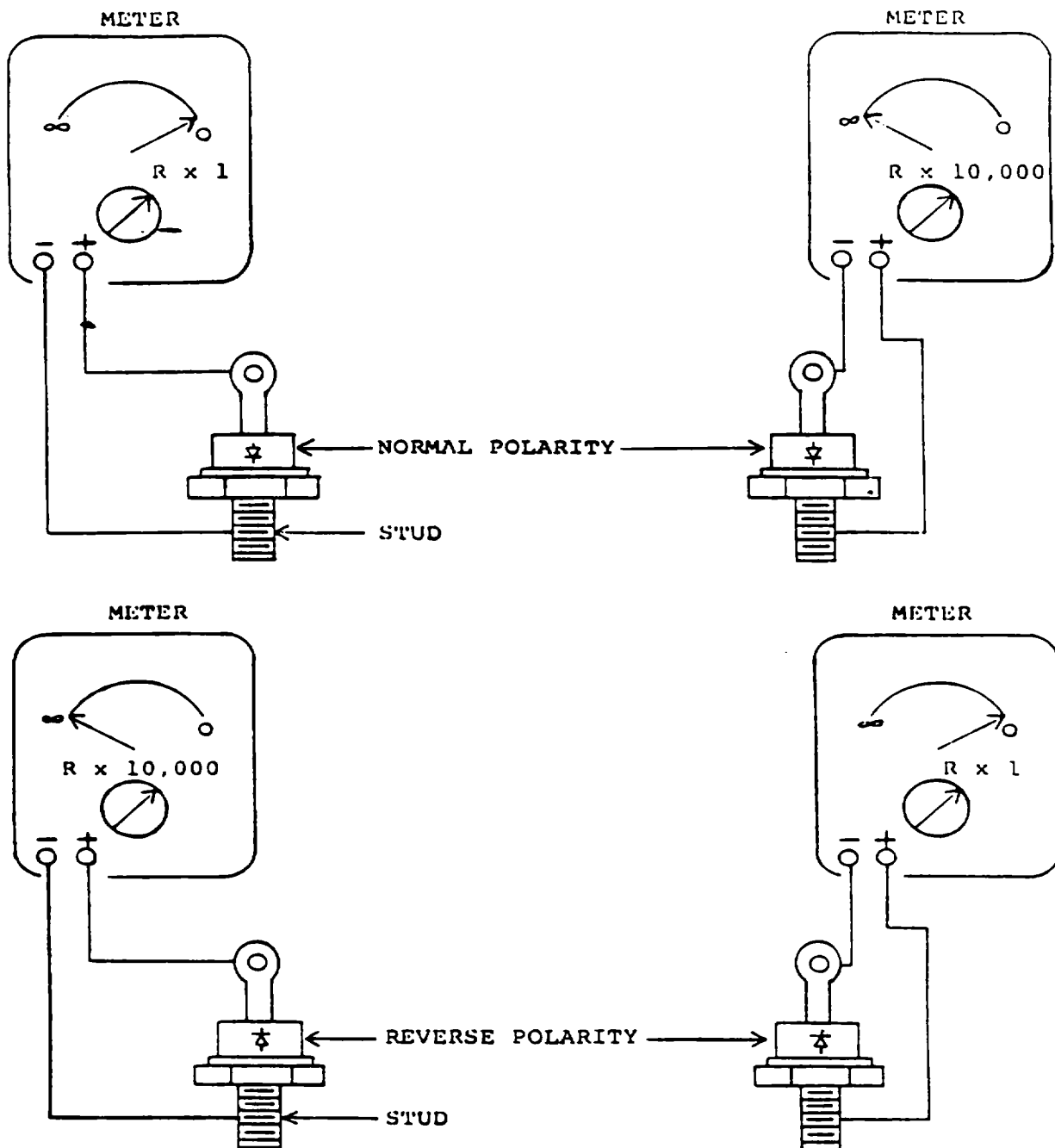
**DIODE TEST INSTRUCTIONS**

NOTE: 1. BE SURE STUD OF DIODE IS REMOVED U130RE TESTING DIODE.

2. REVERSE POLARITY DIODES WILL HAVE AN "R" IN THEIR NUMBER (R3720 OR IN1184R), ALSO ALL DIODES MOUNTED A DYNAMOTE CHASSIS WILL BE REVER-SE POLARITY DIODE (EXCEPT THE: PIONEER 205).

Figure 4.3.10A DIODE CHECKOUT PROCEDURE AND READINGS



#### 4.3.11 ALTERNATOR DIODE TEST PROCEDURE

FOR THIS TEST, DO NOT PUSH OR RELEASE START SWITCH WHEN ENGINE IS ABOVE IDLE.

**Tools Required:** Voltmeter with 0-100 VDC scale.

- 1) Remove the commutation fuses from the inverter front panel.
- 2) Start the engine and run at approximately 1500 RPM.
- 3) Check the voltage from the POSITIVE (+) terminal on the alternator to GROUND.

With the START button depressed, the voltage should read 80 to 110VDC. If not, the alternator diodes are bad and should be replaced. This should be done by an alternator repair shop.

NOTE : If Step 3 is difficult because of the distance from the alternator to the inverter, the alternator voltage can be read from the A+ terminal inside the rear of the inverter.

#### 4.3.12 VEHICLE VOLTAGE REGULATOR, PCB3, CHECKOUT PROCEDURE

**Tools. Required:** Voltmeter with 0-15VDC scale, screwdriver

- 1) Remove the Vehicle Voltage Regulator (VVR) box from the front panel of the inverter by removing the four screws at the corners.
- 2) Remove the VVR Circuit Board from the box by removing the two screws on the outside of the box.
- 3) Check the fuse on the VVR Circuit Board and replace if blown. If not, proceed to the next step.
- 4) With the ignition ON, inverter OFF, and the inverter harnesses still connected, check the voltage from the connector pin #4, GREY wire, to GROUND. The pin next to the edge of the circuit board is pin #5. If the voltage reads 10 volts or more, proceed to Step 5. If there is no voltage, the voltage regulator has failed in the open position and should be replaced.
- 5) To determine if the voltage regulator is regulating properly, start the engine and run at approximately 1500 RPM. Turn on a moderate load, such as the headlights. With the inverter OFF, check the voltage from the inverter B+ (BLACK) terminal post to GROUND (GREEN). If the voltage is other than 13.8 to 14.2VDC, try to adjust it by turning the screw on the grey potentiometer on the vehicle voltage regulator circuit board with a very small screwdriver or knife blade. If the voltage cannot be adjusted to approximately 14.2VDC, the voltage regulator circuit board should be replaced.

NOTE: The inverter voltage regulator, PCB1, inside the inverter front panel is identical to the vehicle voltage regulator and can be used to replace the vehicle voltage regulator until another board can be obtained. It can also be used to confirm the diagnosis of a faulty vehicle voltage regulator circuit board.

© Copyright 1981, DYNAMOTE CORP.

Fig. 4.5.0 G DYNAMIC INVERTER PARTS LIST

Circuit Designation See Pages 4110, 4111 and 4112	Dynamote Part	Description	Used In:			
			BOOSTED			
			A30			
C1	4092-40502	Output Capacitor	x			
C2	4092-40502	Output Capacitor	x			
C3	4092-40502	XFMR. Input Capac.	x			
C4	4095-24712	Commutation Capac.	x			
C5	4093-10147	Contactors Suppression Capacitor	x			
C6, C7	4093-10147	Circuit Board Filter	x			
C9	4095-74606	AC Output Capacitor	x			
C10	4093-10825	Boosted. Field Capacitor	x			
C11	4093-10825	DC Input Capacitor	x			
D1	4121-43700	Unit Isolation Diode	x			
D2	4121-14005	K2 Relay Hold-in Diode	x			
D3, D4	4121-23720	Battery Charging Diode				
D3, D4	4121-11183	Battery Charging Diode	x			
DS, D6	4121-43700	AC Blocking Diode				
D5, D6	4121-11186	AC Blocking Diode	x			
D8, D9	4121-14005	Spike Suppression Diode	x			
D10, D12	4121-22030	Reverse Parallel Diode				
D13	4121-10751	Isolation Diode	x			
D14, D15	4121-20410	Rectification Diode	x			
R1, R2	4681-10025	Stabilizing Resistors	x			
R3	4681-00247	Current Limit Resistor	x			
R4	4681-08020	VR Stabilizing Resis.	x			
R9	4602-20110	Meter Adjustment Potentiometer	x			
F1, F2	4200-06400	Fuses ABU40	x			
F1, F2, F5, F6	4200-06400	Fuses ABU40				
F3, F4	4200-02150	Fuses AGC15	x			
F5	4200-02150	Fuses-AGC15	x			
F7	4200-02150	Fuses AGC15				
F1, F2	4282-00005	Fuse Holders Large HPC	x			
F1, F2, F5, F6	4282-00005	Fuse Holders Large HPC				
F3, F4	4282-00003	Fuse Holders Small HKP	x			
F5	4282-00003	Fuse Holders Small HKP	x			
F7	4282-00003	Fuse Holders Small HKP				
K1	4685-43051	Power Relay	x			
K2	4685-01156	Control Relay	x			
K4	4685-02030	VVR Relay	x			
K5	4685-42592	LVCO Relay				
K3	4685-43051	High Amperage Bypass Relay	*			

\* Optional

4.5.0 DYNAMIC INVERTER PARTS LIST (continued)

Circuit Designation	Dynamote Part	Description	Used In:			
			A30	BOOSTED		
S1, S2	4721-08411	Start/Stop Switch	x			
S4	4721-00256	Field Selection Switch				
B1	4046-12337	Fan Motor	x			
M1	4481-20123	Voltmeter	x			
PCB1	2081-00005	Regulator (Unit)	x			
PCB2	2081-00930	Oscillator	x			
PCB3	2081-00005	Regulator (Vehicle)	x			
PCB4	2081-00200	Load Demand	*			
T1	2764-02007	Transformer/Isolated	x			
SCR1, SCR2	2720-40125	Main SCRs	x			
J3	4080-03080	Control Head Receptacle	x			
J4	4683-25320	Output Receptacle	x			
J7	4080-30160	Test Module Receptacle	x			
X1	4080-04014	Quick Disconnect Black	x			
X2	4080-04013	Quick Disconnect Red	x			
X3	4080-04015	Quick Disconnect Green	x			
X1, X2, X3	4442-90000	Quick Disconnect Lugs	x			

\*-LD Units Only

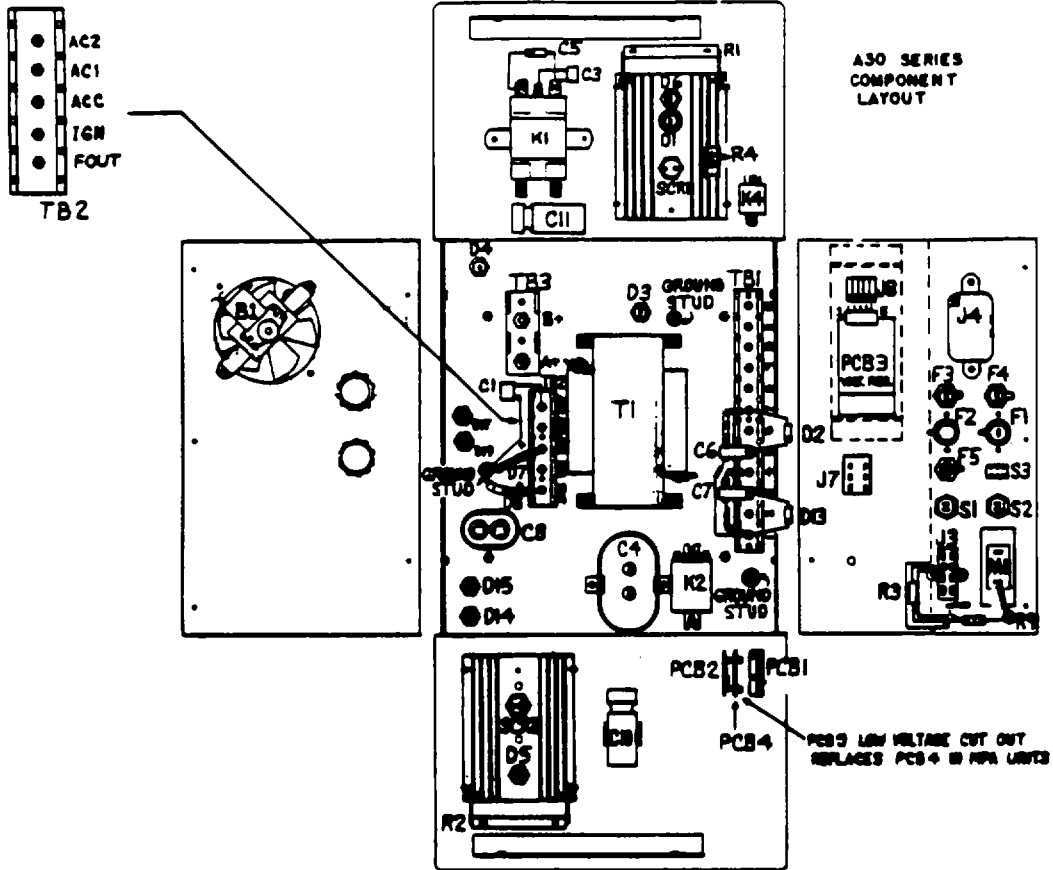

# Instruction Manual



# POWER UNIT

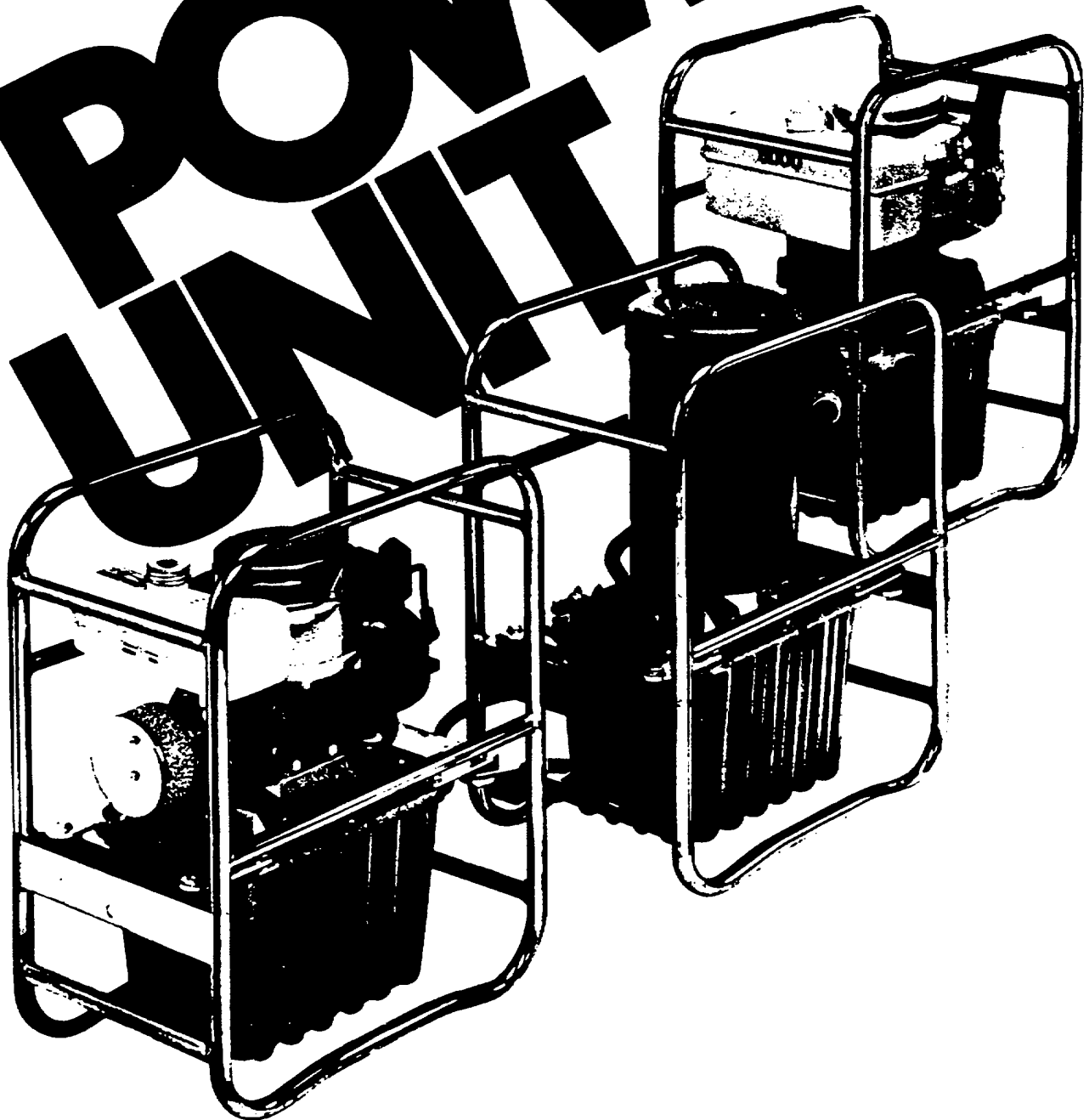

4113

Pages 4100 through 4112 DELETED

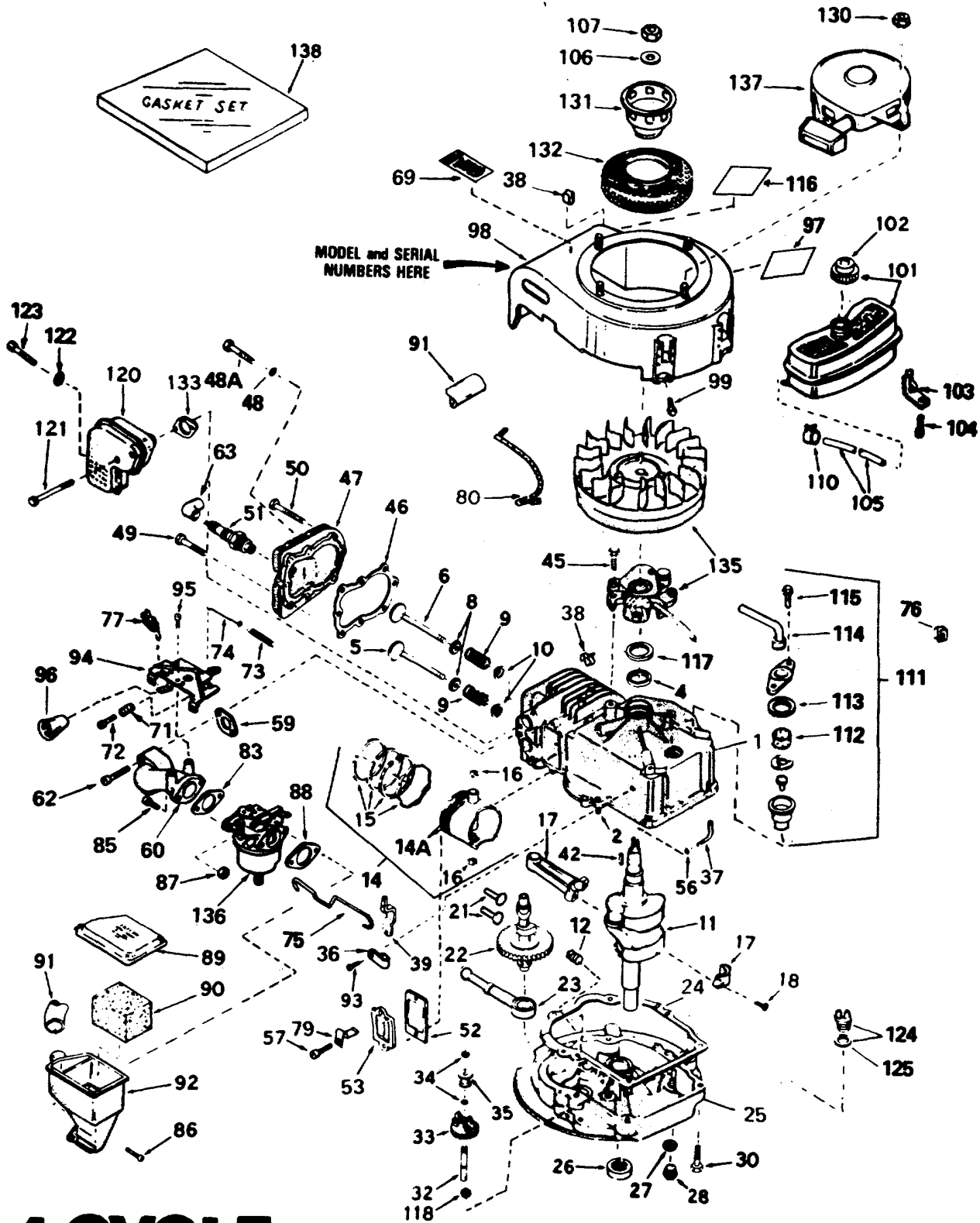

**4 CYCLE**

**4114**

# PARTS LIST

## 4 CYCLE

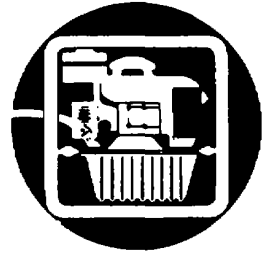

Part No.	Description	Part No.	Description	Part No.	Description
1	33027B Cylinder Assy. (Incl. Nos. 2, 4 & 113)	35	30588A Spool, Governor	93	650548 Screw, Hex Washer Hd., 8-32 x 5/16
2	26727 Pin, Dowel	36	31335 Clamp, Governor Lever	94	32264A Control Assy., Speed (Incl. Nos. 71, 72 & 77)
4	32600 Seal, Oil	37	30589 Rod, Governor	95	30200 Screw, Hex Washer Hd. Sems, self-tap, 10-24 x 9/16
5	32644A Valve, intake (Std.) (Incl. No. 10)	38	27275 Clip, Hi-Tension Wire	96	32410 Knob, Speed Control
6	29313C Valve, Exhaust (Std.) (Incl. No. 10)	39	32651 Lever, Governor	97	31495 Decal, Instruction
8	31671 Cap, Upper Valve Spring	42	610961 Key, Flywheel	98	33738C Housing, Blower
9	31672 Spring, Valve	45	650516 Screw, Hex Hd. Sems, 1/4-20 x 1-1/8	99	650561 Screw, Hex Hd. Sems, 1/4-20 x 5/8
10	31673 Cap, Lower Valve Spring	46	*33015 Gasket, Cylinder Head	101	32871 Tank, Fuel (Incl. No. 102)
11	34567 Crankshaft	47	33016 Head, Cylinder	102	33032 Cap, Fuel
12	9556 Plug, Pipe	48	650691 Washer, Flat	103	34796 Bracket, Tank Retaining
14	34851 Piston, Pln & Ring Assy. (Std.) (Incl. Nos. 14A, 15 & 16)	48A	650818 Screw, Special Hex Hd., 5/16-18 x 1-1/2	104	650665 Screw, Hex Washer Hd. Sems, self-tap, 1/4-14 x 7/8
14A	32603B Piston & Pin Assy. (Std.) (Incl. No. 16)	49	6021A Screw, Hex Flange Hd., 5/16-18 x 1-1/2	106	34357 Line, Fuel
15	34854 Ring Set, Piston (Std.)	50	650694A Screw, Hex Flange Hd., 5/16-18 x 2	108	850815 Washer, Belleville
16	20381 Ring, Piston Pin Retaining	51	33636 Plug, Spark (Champion J-8 or equivalent) (Except for Canada)	107	850818 Nut, Flywheel
17	32875 Rod Assy., Connecting (Incl. No. 18)	52	*27234 Gasket, Valve Spring Box	110	26460 Clamp, Fuel Line
18	32610A Bolt, Connecting Rod	53	32755 Cover, Valve Spring Box	111	34214A Breather Assy.
21	27241 Lifter, Valve	56	28277 Washer, Flat	112	33734 Element, Breather
22	33154 Camshaft (Compression Release)	57	650128 Screw, Fil. Hd. Sems, 10-24 x 1/2	113	*33735 Gasket, Breather
23	29914 Pump Assy., Oil	59	*32649 Gasket, Intake	114	33886 Tube, Breather
24	*26750A Gasket, Mounting Flange	60	32650 Pipe, Intake	115	30200 Screw, Hex Washer Hd. Sems, self-tap, 10-24 x 9/16
25	32612 Flange Assy., Mounting (Incl. Nos. 26, 27, 28 & 32)	62	650664 Screw, Fil. Hd. Sems, 1/4-20 x 1-19/32	116	34346 Decal, Name & Instruction
26	27897 Seal, Oil	63	610118 Cover, Spark Plug	117	33876 Gasket, Stator
27	*28833 Gasket, Oil Drain Plug	69	34316 Decal, Name	118	30590A Washer, Flat
28	27244 Plug, Oil Drain	71	31342 Spring, Compression	120	32648A Muffler
30	650488 Screw, Hex Hd. Sems, 1/4-20 x 1-1/4	72	650549 Screw, Fil. Hd., 5-40 x 7/16	121	850774 Screw, Hex Hd., 1/4-20 x 2-3/8
32	30574 Shaft, Mechanical Governor	73	31386 Spring, Governor	122	8345 Washer, Flat
33	30591 Gear Assy., Governor (Incl. No. 11B)	74	34337 Link, Governor Spring	123	30688 Screw, Hex Hd. Sems, 1/4-20 x 1/2
34	29193 Ring, Retaining	75	34336 Link, Governor-to-throttle	124	27625 Plug Assy., Oil Fill (Incl. No. 125)
		76	29443 Clip, Spring	125	*29673 Gasket, Oil Fill
		77	610973 Terminal Assy.	130	29752 Nut & Lockwasher, 1/4-28
		79	30593 Clip, Wire	131	34694 Cup, Starter
		80	34231 Wire, Ground	132	33868 Screen, Starter
		83	*26756 Gasket, Carburetor	133	*28754 Gasket, Muffler
		85	8201 Screw, Hex Hd., 1/4-28 x 7/8	136	611027 Magneto (The complete magneto is not available as an assembly. The magneto number is shown for reference purposes only. Order component parts individually, as shown in parts list.)
		86	650707 Screw, Fil. Hd. Sems, 10-32 x 5/8		
		87	29752 Nut, Hex w/washer, 1/4-28	136	631597 Carburetor
		88	*33051 Gasket, Cleaner Bracket-to-Carburetor	137	590420 Starter, Rewind
		89	33007 Cover, Air Cleaner	138	33238C Gasket Set (Incl. items marked *)
		90	33006 Element, Air Cleaner		
		91	33008 Tube, Air Cleaner		
		92	33005 Body, Air Cleaner		

\*Indicates Parts Included in Gasket Set, Ref. No. 138.

# POWER UNIT ASSEMBLY

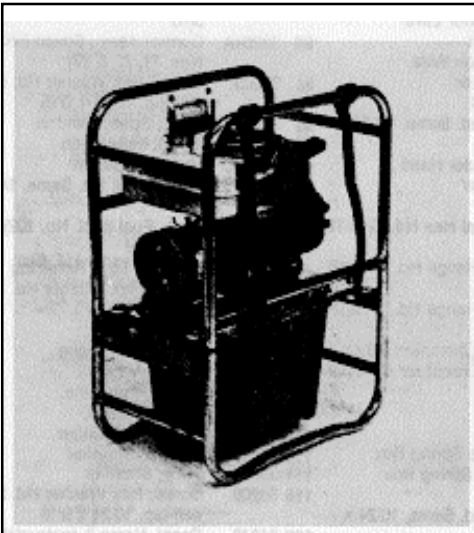
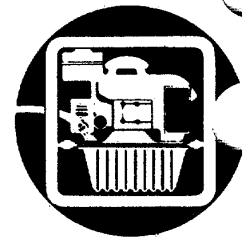

1

Remove the power unit from carton. Visually inspect power unit and confirm that all bolts and screws are securely fastened, and the unit has not been damaged in shipment.

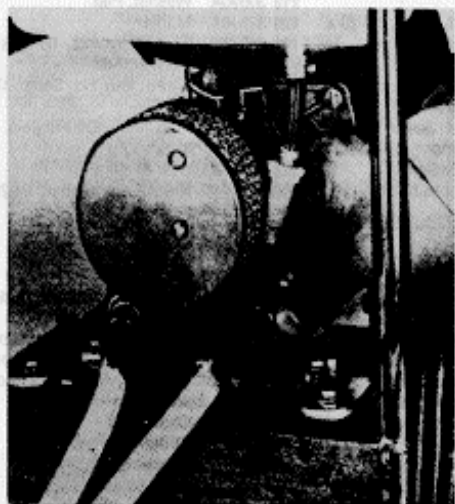

2

Remove nylon caps from 16' length of twin hose and attach to power unit. Match color code on hose and swivel connections.



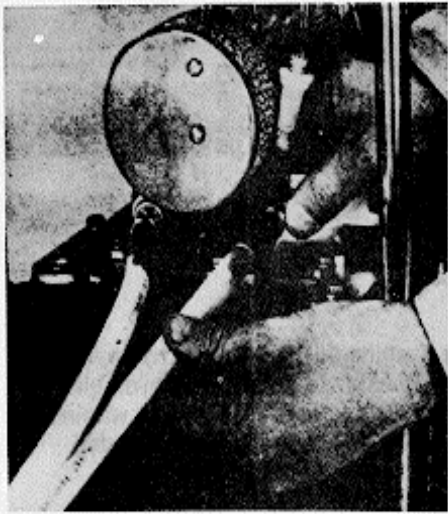

3

Hand tighten both swivel connections on the hose.

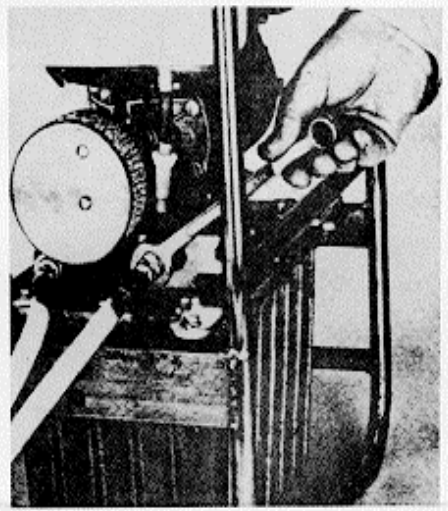

4

Tighten connection using 5/8" open end wrench.

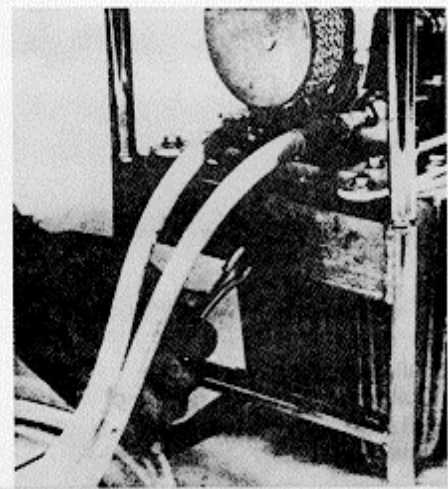

5

Attach strain relief cable with clip through hole at base of power unit.



Remove hex bushing (fill cap) and fill hydraulic reservoir with Phosphate Ester based hydraulic fluid (Hurst RT-23/ Aerosafe 2300). Fill to within 1" from the top. Check with dip stick provided. Replace fill cap and tighten by hand.

6

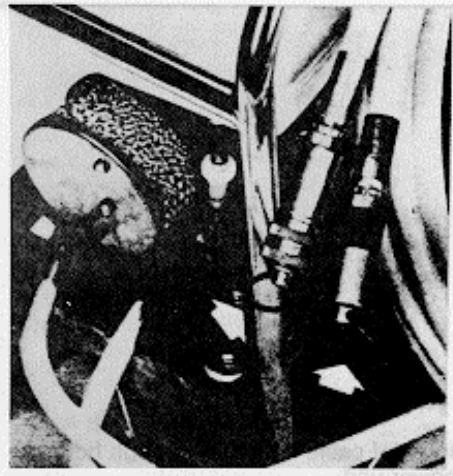

8

Install (optional) caps and plugs in hose connectors. Coil hose and attach to side of power pack roll cage with the two straps provided for this use.

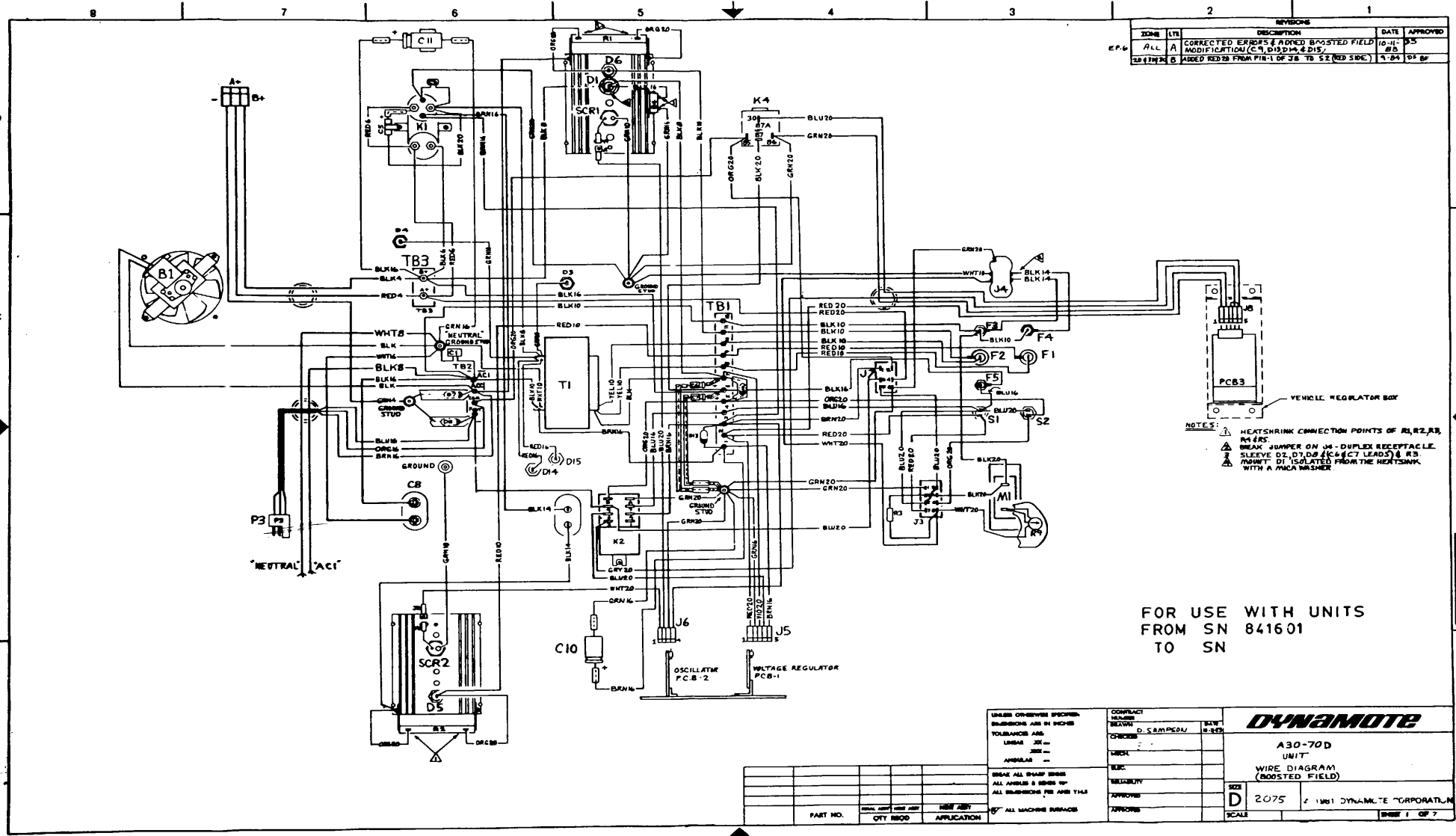

REVISED		DATE	APPROVED
ZONE	LTR	DESCRIPTION	
ALL	A	CORRECTED ERRORS & ADDED BOOSTED FIELD MODIFICATION (C9, D10, D11, & D15)	10-11-65
	B	ADDED RED 20 FROM PIN-1 OF J6 TO S2 (RED SIDE)	9-24-65

- NOTES:
- HEATSHRINK CONNECTION POINTS OF R2, R3, R4 & R5
  - BREAK JUMPER ON J6 - DUPLEX RECEPTACLE
  - SLEEVE D2, D7, D8 & C6 (C7 LEADS) & R3
  - POINT D1 ISOLATED FROM THE HEATSHRINK WITH A PLCA WASHER

FOR USE WITH UNITS  
FROM SN 8416 01  
TO SN

UNLESS OTHERWISE SPECIFIED, DIMENSIONS ARE IN INCHES TOLERANCES ARE:		CONTACT DIMENSIONS: BLW, BLK, GRN, D, S, AMP, C, W, W, K, R		<b>DYNAMOTE</b>
LINEAR	JES	LINEAR	JES	
ANGULAR		LINEAR	JES	A30-70D UNIT WIRE DIAGRAM (BOOSTED FIELD)
BREAK ALL SHARP EDGES ALL ANGLES & ROUNDS UP ALL DIMENSIONS TO NEAREST 1/16"		LINEAR	JES	
BY ALL MACHINE SURFACES		LINEAR	JES	
PART NO.	QTY REQD	REV	APP	SIZE <b>D</b> 2075
				SCALE

2075

A

1 OF 7

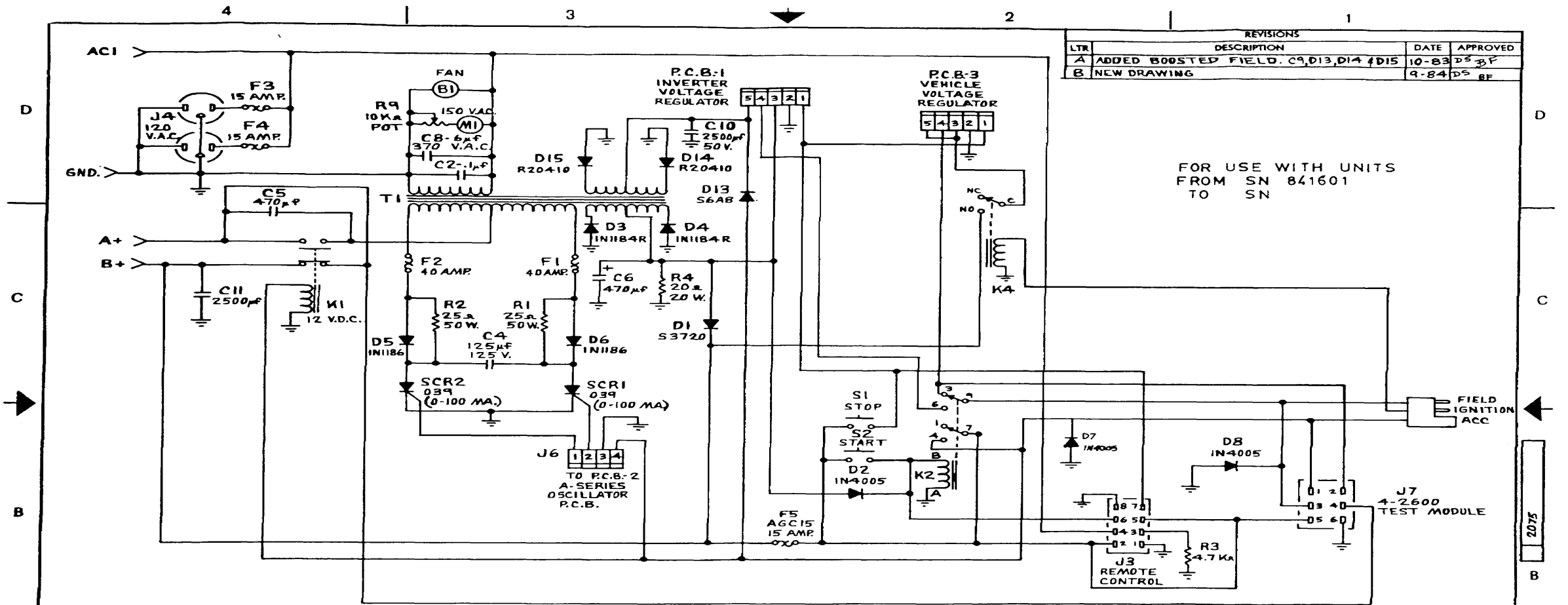

REVISIONS			
LTR	DESCRIPTION	DATE	APPROVED
A	ADDED BOOSTED FIELD. C9, D13, D14 & D15	10-83	D.S. BF
B	NEW DRAWING	9-84	D.S. BF

FOR USE WITH UNITS  
FROM SN 841601  
TO SN

FIELD  
IGNITION  
ACC

J7  
4-2600  
TEST MODULE

J3  
REMOTE  
CONTROL

UNLESS OTHERWISE SPECIFIED:  
DIMENSIONS ARE IN INCHES  
TOLERANCES ARE  
LINEAR .001  
HOLE .001  
ANGULAR .001  
BREAK ALL SHARP EDGES  
ALL ANGLES & BENDS 90°  
ALL DIMENSIONS PER ANSI Y14.5  
ALL MACHINE SURFACES

CONTRACT NUMBER  
DRAWN D. SAMPSON DATE 9-84  
CHECKED  
MECH.  
ELEC.  
RELIABILITY  
APPROVED  
APPROVED

**DYNAMOTE**

A 30-70D  
UNIT - SCHEMATIC

SIZE  
C 2075  
SCALE

SHEET 2 OF

PART NO.	FINAL ASY	NEXT ASY	NEXT ASY
	QTY REQD		APPLICATION

Pages 4103 through 4112 DELETED

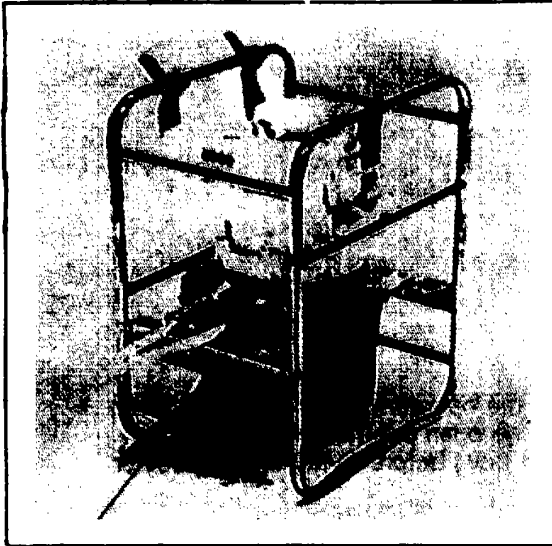

9

**4 Cycle Power Unit:**

Follow steps 1 thru 6 of power unit assembly.  
Fill oil reservoir to full mark on oil dip stick and  
fill fuel tank with regular gasoline.

**CAUTION:** Be sure to use 30 weight engine oil  
in engine crankcase. Fill to mark on dipstick,  
**before starting engine.** Engine crankcase  
shipped without oil.

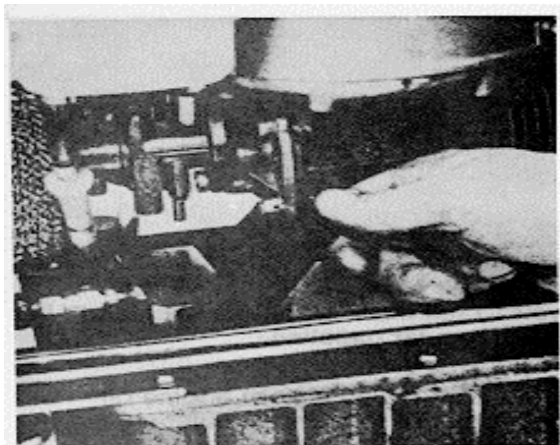

12

Make sure the operating lever on the by pass valve is in the open position (away from the direction of flow) before trying to start power unit.

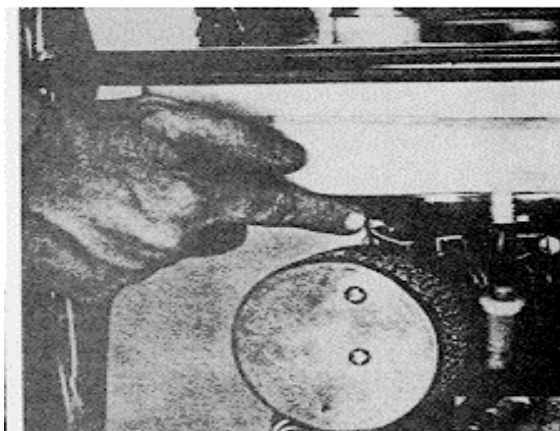

13

START-UP

Begin "start up" sequence. Move the choke lever on the power unit engine control to the closed position.

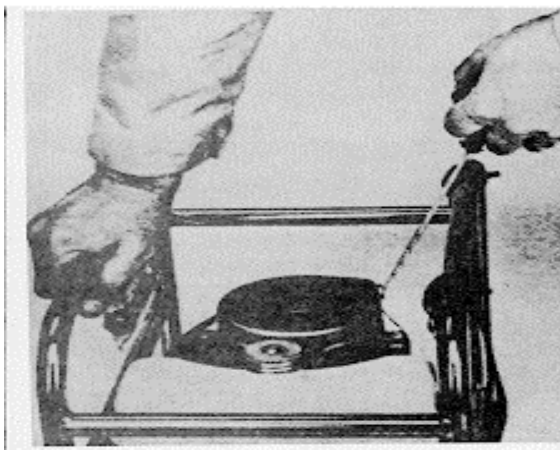

14

Check operating lever for the governor control. Secure in the "run" position. Pull starter cord several times to prime carburetor, until engine pops.

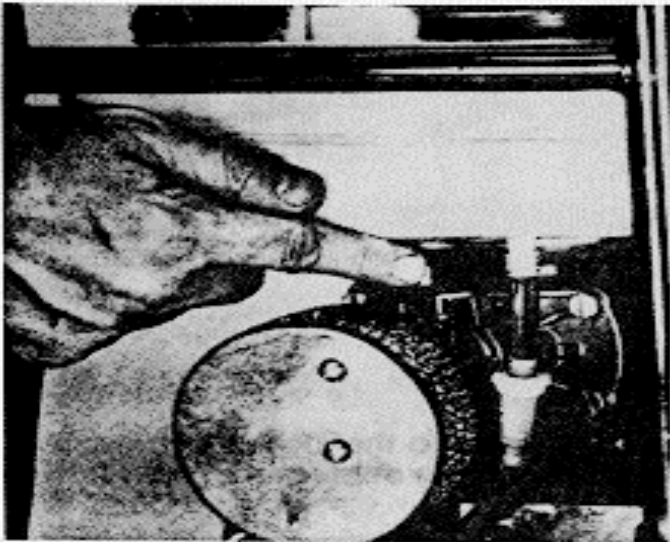

15

Return choke to the "open" position.

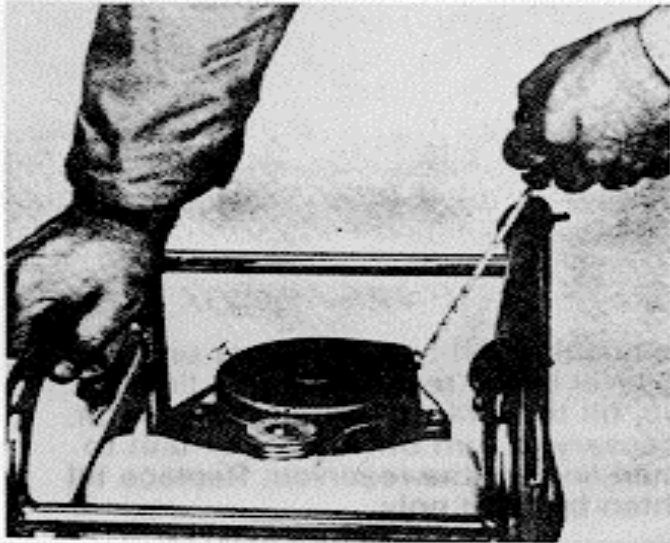

16

Hold roll cage with one hand and pull cord with other. Pull cord sharply and the engine should start. If the new engine does not run after several pulls, repeat the starting procedure.

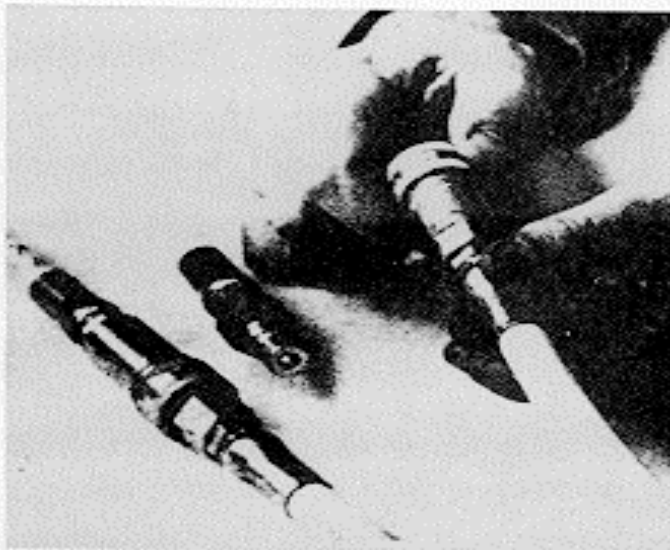

17

Connect the couplings from the tool to the Bruning couplings on the long hoses from the power unit before operating the by pass valve to the closed position.

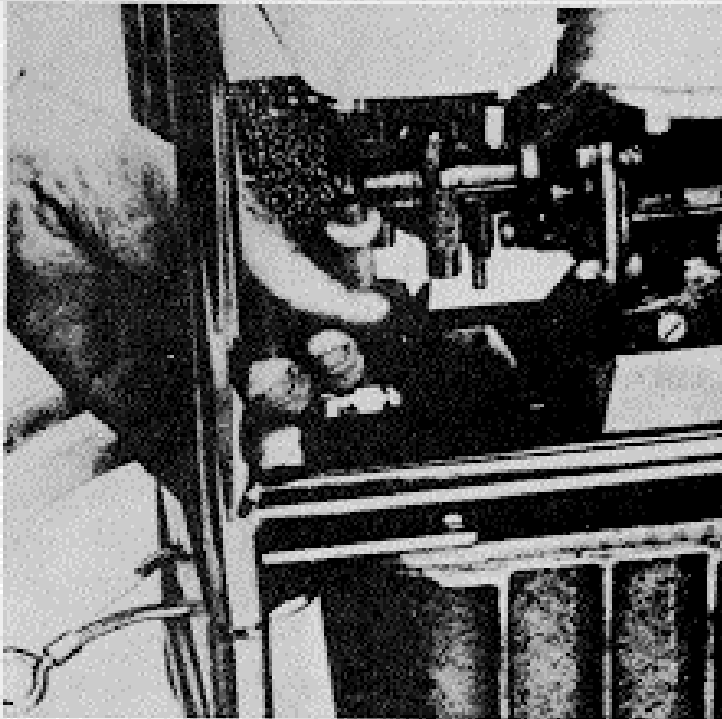

18

Move the operating lever to the closed or run position after power unit is started and tool(s) are connected.



19

Remove hex bushing (fill cap) on power unit and check liquid level in the reservoir. If the liquid level is down, fill to within 1" of top of reservoir. It is not necessary to turn off the power unit to check the fluid level in the reservoir. Replace fill cap and tighten by hand only.

Pages 4123 through 4125 DELETED



# TROUBLESHOOTING POWER UNIT

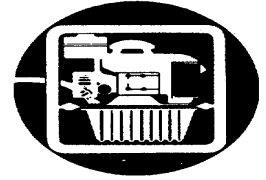

## PROBLEM

Engine fails to start or starts with difficulty

## CAUSE

- No fuel in tank

## REMEDY

- Fill tank with clean, fresh fuel

Shut-off valve closed

- Open v• Obstructed fuel line
- Tank cap vent obstructed
- Water in fuel
- Engine overchoked
- Improper carburetor adjustment
- Loose or defective magneto wiring
- Faulty Magneto
- Spark plug fouled
- Spark plug porcelain cracked
- Poor compression
- No spark at plug

- Clean fuel screen and line. If necessary, remove and clean carburetor
- Open vent in fuel tank cap
- Drain tank. Clean carburetor and fuel lines
- Dry spark plug points. Fill tank with clean, fresh fuel
- Close fuel shut-off and pull starter until engine starts. Reopen fuel shut-off for normal fuel flow
- Adjust carburetor
- Check magneto wiring for shorts or grounds; repair if necessary
- Check timing, point gap, and if necessary, overhaul magneto
- Clean and regap spark plug
- Replace spark plug
- Overhaul engine
- Disconnect ignition cut off wire at the engine. Crank engine. If spark at spark plug, ignition switch, safety switch or interlock switch is inoperative. If no spark, check magneto. Check wires for poor connections, cuts or breaks

Engine misses under load

- Spark plug fouled
- Spark plug porcelain cracked
- Improper spark plug gap
- Pitted magneto breaker points
- Magneto breaker arm sluggish
- Faulty condenser (except on Tecumseh Magneto)
- Improper carburetor adjustment
- Improper valve clearance
- Weak valve spring

- Clean and regap spark plug
- Replace spark plug
- Regap spark plug
- Replace pitted breaker points
- Clean and lubricate breaker point arm
- Check condenser on a tester, replace if defective
- Adjust carburetor
- Adjust valve clearance to .010 cold
- Replace valve spring

Engine lacks power

- Choke partially closed
- Improper carburetor adjustment

- Open choke
- Adjust carburetor

Pages 4123 through 4125 DELETED  
4126

	<ul style="list-style-type: none"> <li>• Magneto improperly timed</li> <li>• Worn rings</li> <li>• Lack of lubrication</li> <li>• Air cleaner fouled</li> <li>• Valves leaking</li> </ul>	<ul style="list-style-type: none"> <li>• Time magneto</li> <li>• Replace rings</li> <li>• Fill crankcase to the proper level</li> <li>• Clean air cleaner</li> <li>• Grind valves and set to .010 cold</li> </ul>
Engine surges or runs unevenly	<ul style="list-style-type: none"> <li>• Fuel tank cap vent hole clogged</li> <li>• Governor parts sticking or binding</li> <li>• Carburetor throttle linkage or throttle shaft and or butterfly binding or sticking</li> <li>• Intermittent spark at spark plug</li> <li>• Improper carburetor adjustment</li> <li>• Dirty carburetor</li> </ul>	<ul style="list-style-type: none"> <li>• Open vent hole</li> <li>• Clean, and if necessary repair governor parts</li> <li>• Clean, lubricate, or adjust linkage and deburr throttle shaft or butterfly</li> <li>• Disconnect ignition cut-off wire at the engine. Crank engine. If spark, check ignition switch, safety switch and interlock switch. If no spark, check magneto. Check wires for poor connections, cuts or breaks.</li> <li>• Adjust carburetor</li> <li>• Clean carburetor</li> </ul>
Engine overheats	<ul style="list-style-type: none"> <li>• Engine improperly timed</li> <li>• Carburetor improperly adjusted</li> <li>• Air flow obstructed in shrouds</li> <li>• Cooling fins clogged</li> <li>• Excessive load on engine</li> <li>• Carbon in combustion chamber</li> <li>• Lack of lubrication</li> </ul>	<ul style="list-style-type: none"> <li>• Time engine</li> <li>• Adjust carburetor</li> <li>• Remove any obstructions from air passages</li> <li>• Clean cooling fins</li> <li>• Check operation of associated equipment</li> <li>• Reduce excessive load</li> <li>• Remove cylinder head or cylinder and clean carbon from head and piston</li> <li>• Fill crankcase to proper level</li> </ul>
Engine uses excessive	<ul style="list-style-type: none"> <li>• Engine speed too fast</li> <li>• amount of oil</li> <li>• Oil level too high</li> <li>• Oil filler cap loose or gasket damaged causing spillage out of breather</li> <li>• Breather mechanism damaged or dirty causing leakage</li> <li>• Drain hole in breather box clogged causing oil to spill out of breather</li> <li>• Gaskets damaged or gasket surfaces nicked causing oil to leak out</li> <li>• Valve guides worn excessively thus passing oil into combustion chamber</li> <li>• Cylinder wall worn or glazed, allowing oil to bypass rings into combustion chamber</li> <li>• Piston rings and grooves worn excessively</li> <li>• Piston fit undersized</li> <li>• Piston oil control ring return holes clogged</li> <li>• Oil passages obstructed</li> </ul>	<ul style="list-style-type: none"> <li>• Using tachometer adjust engine RPM to spec</li> <li>• To check level turn dipstick cap tightly into receptacle for accurate level reading</li> <li>• Replace ring gasket under cap and tighten cap securely</li> <li>• Replace breather assembly</li> <li>• Clean hole with wire to allow oil to return to crankcase</li> <li>• Clean and smooth gasket surfaces. Always use new gaskets</li> <li>• Ream valve guide oversize and install 1132" oversize valve</li> <li>• Bore hole, or deglaze cylinder as necessary</li> <li>• Reinstall new rings and check land clearance and correct as necessary</li> <li>• Measure and replace as necessary</li> <li>• Remove oil control ring and clean return holes</li> <li>• Clean out all oil passages</li> </ul>
Oil seal leaks	<ul style="list-style-type: none"> <li>• Crankcase breather</li> <li>• Old seal hardened and worn</li> <li>• Crankshaft seal contact surface is worn undersize causing seal to leak</li> <li>• Crankshaft bearing under seal</li> </ul>	<ul style="list-style-type: none"> <li>• Clean or replace breather</li> <li>• Replace seal</li> <li>• Check crankshaft size and replace if worn excessively</li> <li>• Check crankshaft bearings for wear and</li> </ul>

	<p>is worn excessively, causing crankshaft to wobble in oil seal</p> <ul style="list-style-type: none"> <li>• Seal outside seat in cylinder or side cover is damaged, allowing oil to seep around outer edge of seal</li> <li>• New seal installed without correct seal driver and not seating squarely in cavity</li> <li>• New seal damaged upon installation</li> <li>• Bent crankshaft causing seal to leak</li> <li>• Oil seal driven too far into cavity</li> </ul>	<p>replace if necessary</p> <ul style="list-style-type: none"> <li>• Visually check seal receptacle for nicks and damage. Replace P.T.O. cylinder cover, or small cylinder cover on the magneto end if necessary</li> <li>• Replace with new seal, using proper tools and methods</li> <li>• Use proper seal protector tools and methods for installing another new seal</li> <li>• Check crankshaft for straightness and replace if necessary</li> <li>• Remove seal and replace with new seal, using the correct driver tool and procedures</li> </ul>
Breather passing oil	<ul style="list-style-type: none"> <li>• Engine speed too fast</li> <li>• Loose oil fill cap or gasket damaged or missing</li> <li>• Oil level too high</li> <li>• Breather mechanism damaged</li> <li>• Breather mechanism dirty</li> <li>• Drain hole in breather box clogged</li> <li>• Piston ring end gaps aligned</li> <li>• Breather mechanism installed upside down</li> <li>• Breather mechanism loose</li> <li>• Damaged or worn oil seals on end of crankshaft</li> <li>• Rings not properly seated</li> <li>• Breather assembly not assembled correctly</li> <li>• Cylinder cover gasket leaking</li> </ul>	<ul style="list-style-type: none"> <li>• Use tachometer to adjust correct RPM</li> <li>• Install new ring gasket under cap and tighten securely</li> <li>• Check oil level - Turn dipstick cap tightly into receptacle for accurate level reading. DO NOT fill above full mark</li> <li>• Replace reed plate assy.</li> <li>• Clean thoroughly in solvent. Use new gaskets when reinstalling unit</li> <li>• Clean hole with wire to allow oil to return to crankcase</li> <li>• Rotate end gaps so as to be staggered 90° apart</li> <li>• Small oil drain holes must be down to drain oil from mechanism</li> <li>• Install new gaskets and tighten securely or gaskets leaking</li> <li>• Replace seals</li> <li>• Check for worn, or out of round cylinder. Replace rings. Break in new rings with engine working under a varying load. Rings must be seated under high compression, or in other words, under varied load conditions.</li> <li>• See section on Breather Assembly</li> <li>• Replace cover gasket</li> </ul>



50 WEST STREET RD., WARMINSTER, PA 18974  
(215) 672-1700 • TWX 510-665-5425



4129

PRINTED IN USA • 159 R029 00 • 2M1281 • PATENT PENDING

Hurst Safety Products reserves the to make changes at any time, without notice or obligation, in prices, materials, equipment or specifications, and to change or discount models. Check with distributor for current information.

Instruction Manual



SAFETY  
DUCTS  
VISION

# 3228



# JANS OF LIFE®

# RESCUE TOOL

# 32

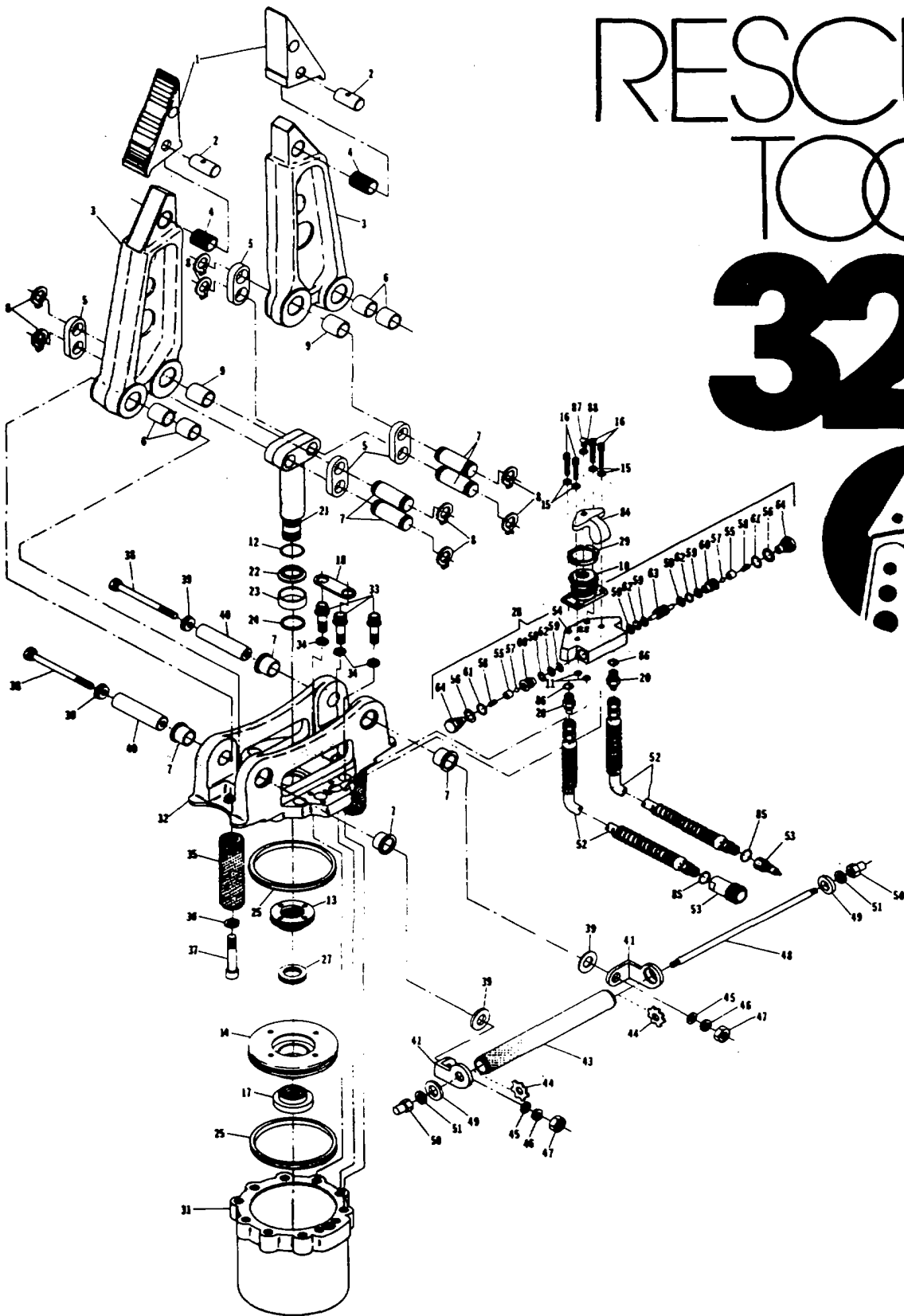
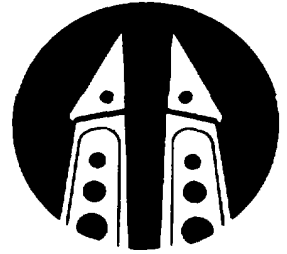

# 320 PARTS LIST

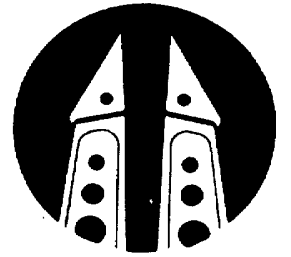

Part No.	Description	Part No.	Description	Part No.	Description
1	347-R012 Jaw Automotive	33	215-0050 12 Point Cap Screw	62	337-0017 "O" Ring
2	189-0015 Jaw Retainer Pin	34	267-0037 Flat Washer	63	350-R001 Piston, Pilot Ck. Valve
3	105-R002 Arm	35	349-8650 Handle	64	357-R001 Plug
4	118-0009 Jaw Pin Bushing	36	267-8745 Flat Washer	65	347-R008 A.C. Cutting Jaw
5	171-R007 Link	37	215-0046 Socket Hd. Cap Screw	66	347-R007 A.C. Spreading Jaw
6	118-R001 Arm Bushing, Pivot Pin	38	215-0047 Cap Screw	67	353-0013 Hose W/Strain Relief 16'
7	189-0029 Link Pin	39	228-0043 Bracket Spacer	68	353-0014 Hose W/S.R. & Conn. 16'
8	211-0018 Retainer Ring	40	189-0024 Pivot Pin	69	353-0012 Hose 18' Twinned
9	118-R002 Arm Bushing, Link Pin	41	117-0066 Handle Bracket, L.H.	70	353-0016 Hose W/2 Conn. 16'
10	266-R007 Valve W/Hard Pin	42	117-0065 Handle Bracket, R.H.	71	364-8881 Chain & Hook Assy.
11	337-R005 "O" Ring, Valve Base	43	404-0007 Handle	72	305-0002 Clevis Link
12	337-R018 "O" Ring, Piston Rod	44	267-0040 Ext. Tooth Lock Washer	73	189-0018 Clevis Link Pin (Fas P)
13	208-R003 Piston Retainer, Upper	45	267-8742 Lock Washer	74	180-8751 Hydraulic Fluid/Qts.
14	350-R003 Piston, Aluminum	46	267-8818 Flat Washer	75	305-0003 Grab Hook
15	267-R006 Lock Washer Split	47	179-3491 Hex Nut	76	257-0003 Tool Kit
16	215-R022 Socket Hd. Cap Screw	48	213-0060 Handle Rod	77	364-0003 Chain & Shackle Pkg.
17	208-R004 Piston Retainer, Lower	49	267-8745 3/8" Flat Washer	77a	364-0008 12' Chain W/Hooks
18	244-0004 Locking Plate	50	179-0023 Acorn Hex. Lock Nut	78	353-0022 30' Hose W/2 Conn.
20	142-0049 Male Fitting, 37" x 7/16-20	51	267-3464 Lock Washer	79	364-0004 Two Link Chain
21	213-R004 Piston Rod	52	353-0033 Hose, Pressure & Return, 15"	80	347-R008 Aircraft Jaw Set (2)
22	218-8732 Piston Rod Wiper	53	128-0008 Connector Set, 1M 1F	81	337-R001 Connector "O" Ring
23	118-8663 Piston Rod Bushing	54	112-R001 Valve Block	83	180-0006 Pist N Lube (Case)
24	216-8712 Piston Rod Seal	55	208-R001 Cup	84	335-R002 Thumb Control
25	216-8711 "T" Ring Piston Seal	56	211-R002 Retainer Ring	85	337-0024 "O" Ring
27	216-R004 "T" Ring Piston Rod	57	318-R001 By Pass Valve Ball	86	337-R005 "O" Ring, Valve Base
28	112-R002 Dual Pilot Check Valve	58	230-R002 Spring	87	271-0001 Truss Head Screw
29	243-R001 Trigger Stop (Valve Ring)	59	211-R001 Retainer Ring	88	267-4074 Flat Washer
31	392-0009 Housing Assembly	60	313-R001 Seat		
32	145-0014 Frame Assembly	61	337-R012 "O" Ring		

## ACCESSORIES

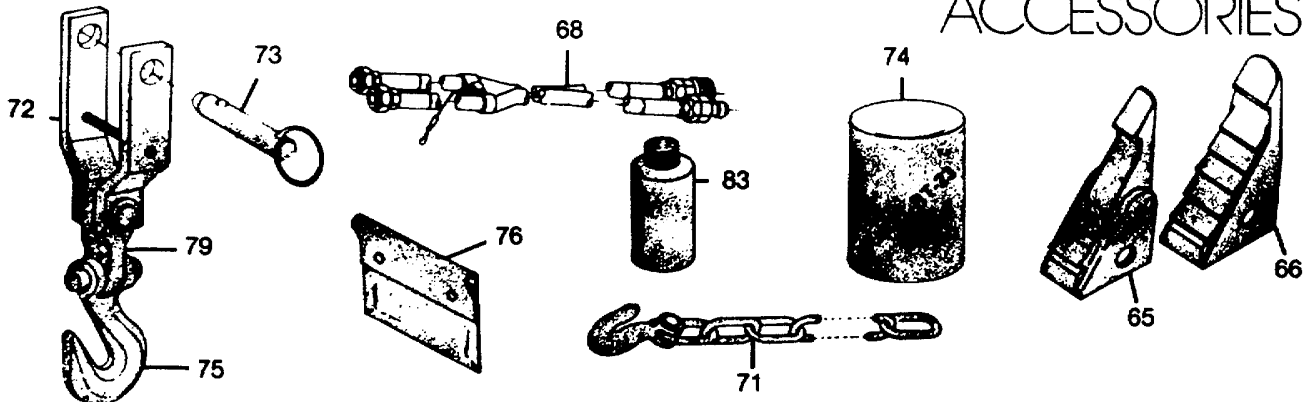

# 3220 ASSEMBLE

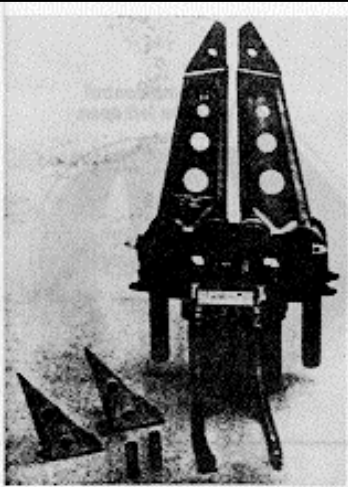
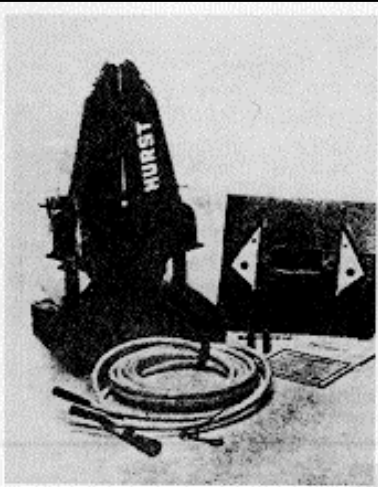
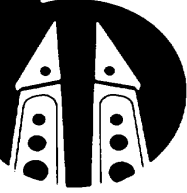

1

Remove Rescue Tool from carton; Inspect unit and confirm that: all bolts and screws are securely fastened, and the unit has not been damaged in shipment.

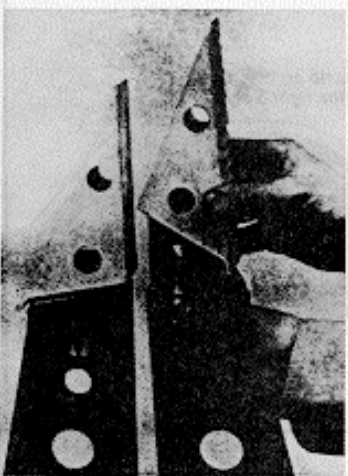

2

Attach all sets of Jaws enclosed to both arms to insure both interchangeability and fit of Jaws to the arms of the tools. Attach automotive Jaws to the tool and insert Jaw retainer pins.

4133



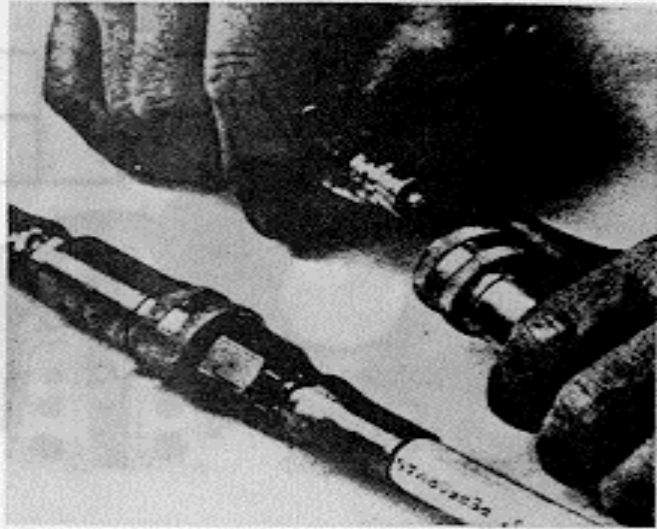

3

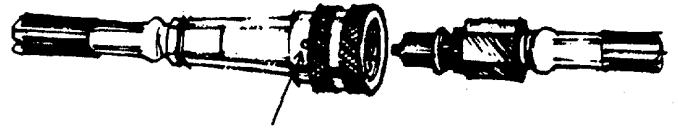

*Align slot with pin before you connect or disconnect couplings*

Connect couplings on the short hoses from the tool to the couplings on the long hoses from the power unit.

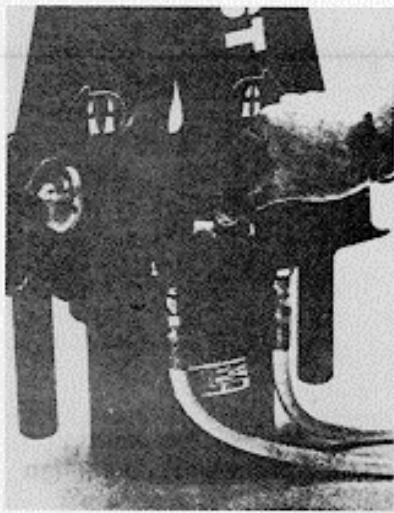

4

Operate thumb control several cycles until the arms operate smoothly through full range of movement - from open to close. The hydraulic system is self purging and the cycling eliminates air from the system.

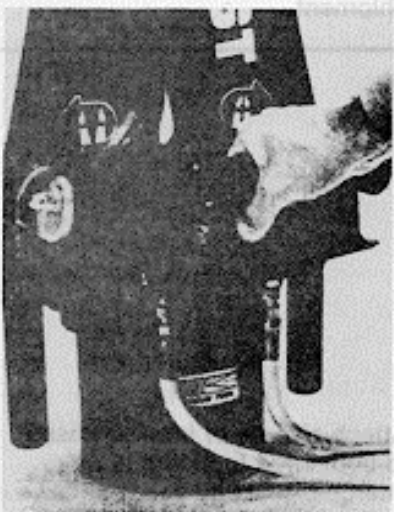

5

Move the thumb controls to the left to open or spread the arms of the tool. If the controls do not operate the arms in this manner, the hoses have been connected incorrectly on either the tool or the power unit. Check the color coding on both and correct. (Turn by-pass valve on the power unit "OFF" before breaking hose connections.)

4134

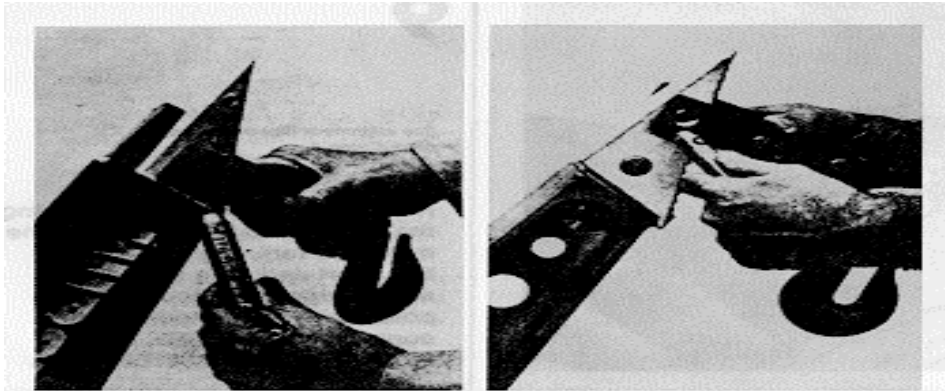

6

To attach chain shackles to the tool, force short jaw retainer pins out of the arm. (Model 28 only)

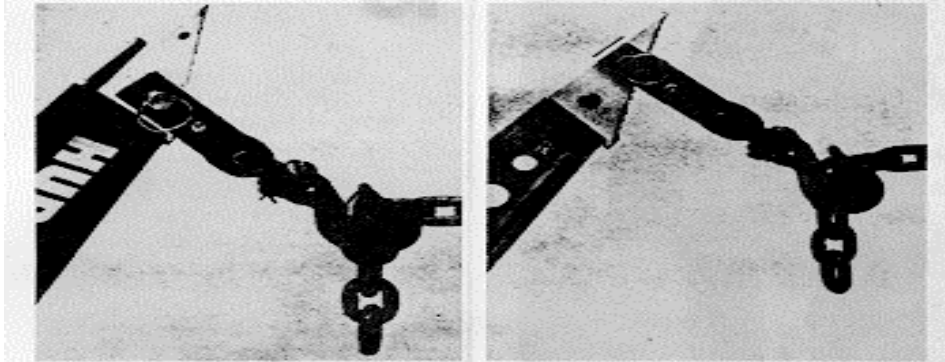

7

Slip chain shackle over the jaw and insert long fastener, through hole in the jaw locking shackle to arm. (Model 32B only)

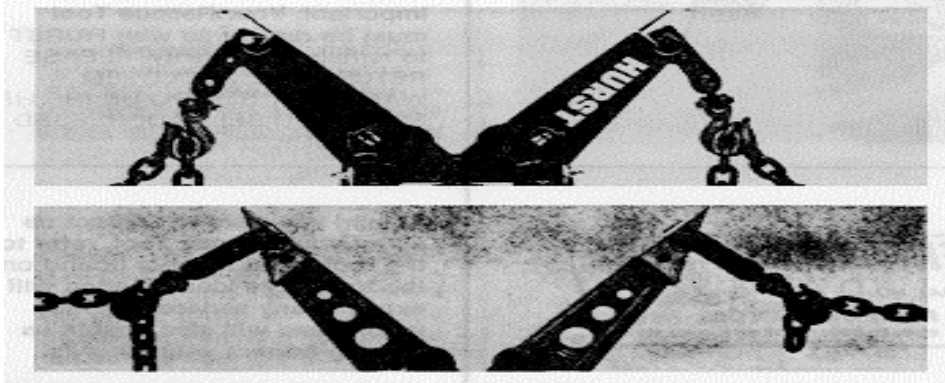

8

Make sure hooks are both facing the same direction, up or down. Attach the chains from the same direction (side) to prevent the arms from twisting.

4135

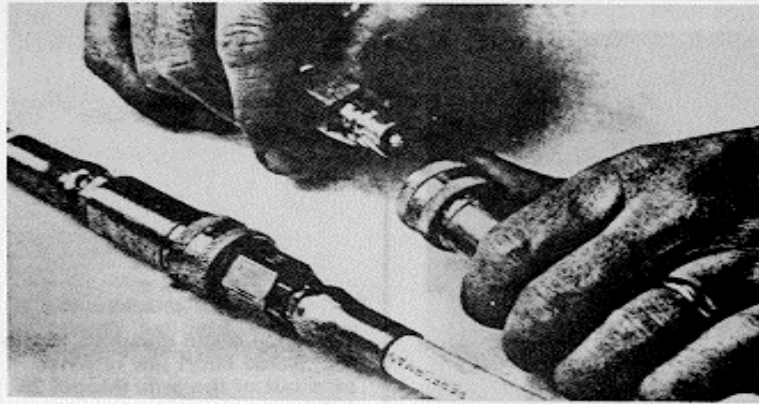

9

*So alignment illustration on page 6 step 3*

After storage and before re-using the Rescue Tool, disconnect the male and female couplings on the short and long hoses and attach together to connect the power unit to the tool. Make connections **BEFORE STARTING THE POWER UNIT.**

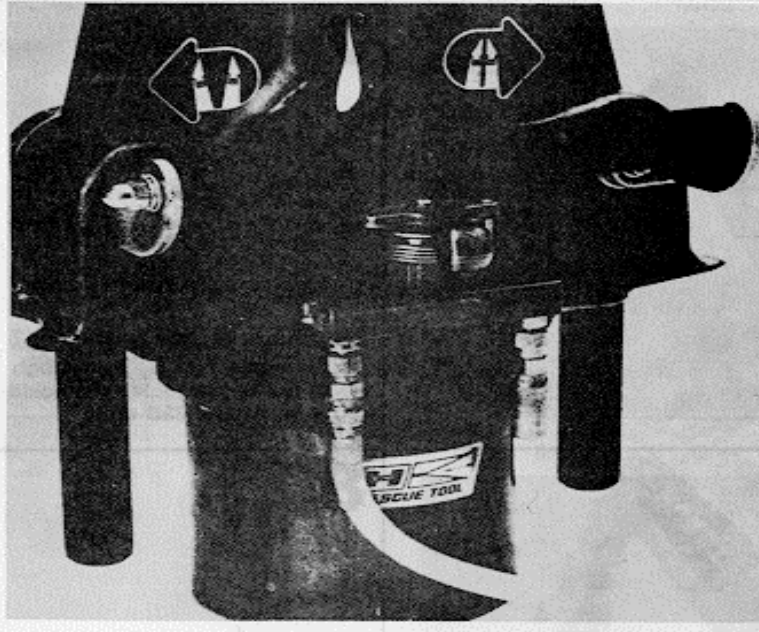

10

Important: Your Rescue Tool must be registered with HURST to remain in warranty. **PLEASE RETURN THE ENCLOSED WARRANTY SLIP TO US IN THE ENCLOSED SELF-ADDRESSED ENVELOPE.**



Should you have to contact us about your Rescue Tool, refer to the tool serial number (found on the tool). This Identification will expedite any service you may require and will also enable us to keep current your records.



## AND GENERAL MAINTENANCE\*

### LUBRICATION

- Grease control spring and links with Hurst's Shifty Doctor Grease.
- Spray jaws, Jaw retainer pins, arms, frame and cylinder with silicone lubricant.
- Excess grease and lubricant should be removed.

### DAILY MAINTENANCE/INSPECTION

- Inspect carefully for Hydraulic leaks.
- Inspect hoses and couplings for wear or damage.
- Check control valve operation for easy operation and free return.
- Check inside frame for dirt & debris.
- Be sure all parts are clean.
- Check jaws for damage.
- Check the unit that all nuts, bolts, retainer rings and screws are in place and securely fastened.

### STORAGE

- Protect unit against or store in location free of moisture.
- Store in space adequate to prevent damage to hoses, connectors or tool itself.

### AFTER USE MAINTENANCE

- Clean and lubricate.
- Check for wear or damage on all parts.
- Check all nuts, bolts, retainer rings, screws, and pins are in place and securely fastened.

- Check for wear or damage on all parts.
- Check all nuts, bolts, retainer rings, screws, and pins are in place and securely fastened.

### 6 MONTH OR 50 USE HOURS MAINTENANCE

- Pressure check all valve and internal seals. Replace as required.
- Check AC and Auto Jaws for damage and wear. Replace as required.
- Check hose and couplings for damage, replace as required. • Clean and lubricate.

### ANNUAL INSPECTION

- Pressure check valves and internal seals. Replace as required.
- Check operating pressure, unloaded, through full operating cycle.
- Magnaflux or penetrant dye check Auto and AC jaws.
- Check force output of tool under load in opening and closing modes, at 18" S 2" open at tip of Jaws.
- Replace operating decals.
- Replace hoses, couplings and fasteners as required.
- Clean and lubricate.

- Call your authorized Hurst Distributor for maintenance and annual inspection care.

## TROUBLE SHOOTING GUIDE 32B/28

PROBLEM	CAUSE	REMEDY
Tool operates eratically, slowly, or fails to operate	<ul style="list-style-type: none"> <li>• Hydraulic Fluid is low.</li> <li>• Air In Hydraulic System</li> <li>• Valve thumb control level loose.</li> </ul>	<ul style="list-style-type: none"> <li>• Check fluid level in reservoir and add fluid as required.</li> <li>• Cycle tool full open to fully closed several times.</li> <li>• Tighten or replace screw on thumb control lever, or replace thumb control lever assembly as required.</li> </ul>
Tool has apparent loss of power	<ul style="list-style-type: none"> <li>• Leak In valve seals</li> <li>• Internal 'T' Ring seal failure.</li> <li>• Piston failure</li> </ul>	<ul style="list-style-type: none"> <li>• Replace all "O" rings in valve and between valve and D.P.C.V. valve block*</li> <li>• Remove internal seals and replace with new "T, seals*.</li> <li>• Remove and replace piston.</li> </ul>
Tool fails to operate	<ul style="list-style-type: none"> <li>• Coupling failure - fails to open Internal check when connected.</li> <li>• Pilot operated check valve falls to open.</li> <li>• No flow from Power Unit</li> </ul>	<ul style="list-style-type: none"> <li>• Replace coupling</li> <li>• Replace dual pilot "O" Rings or springs as required.</li> <li>• Check power and repair as required.</li> </ul>
Tool operates In reverse	<ul style="list-style-type: none"> <li>• Hoses reversed on power supply</li> <li>• Connectors reversed on tool</li> </ul>	<ul style="list-style-type: none"> <li>• Reverse hoses from Power Unit.</li> <li>• Reverse connectors on short hose on the tool.</li> </ul>
Jaw Retainer Pin fails to stay In arm	<ul style="list-style-type: none"> <li>• Detent ball on pin is jammed w/dirt or grit</li> <li>• Spring on detent ball broken</li> </ul>	<ul style="list-style-type: none"> <li>• Flush dirt or grit from pin till ball moves freely; replace If necessary.</li> <li>• Replace jaw retainer pin.</li> </ul>

- Call your authorized Hurst Distributor for maintenance and annual Inspection care.

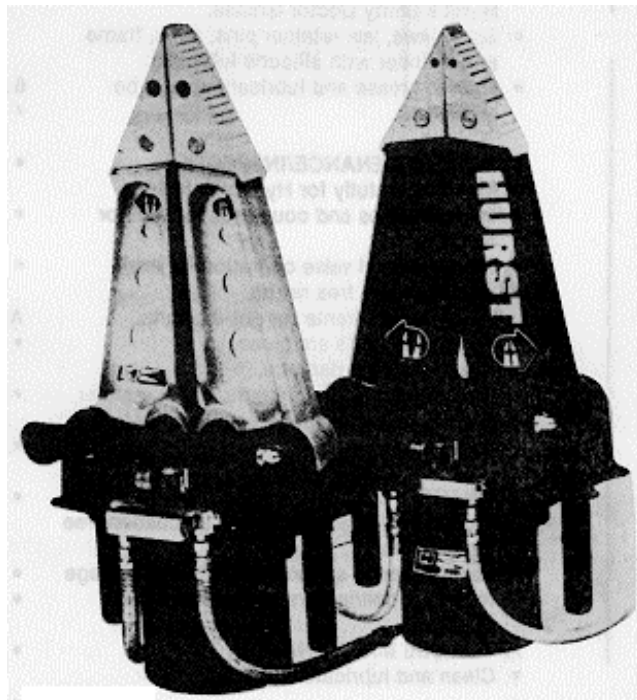

# 3200

## ROOF SHOOTING



1

To raise the car roof, insert the jaws of the Rescue Tool between the roof of the automobile and the top of the door, hinged side, if possible, or any firm surface. Move the operating thumb control to the "open" position, and open the Jaws. The tool will open insuring sufficient opening to survey the interior of the vehicle.

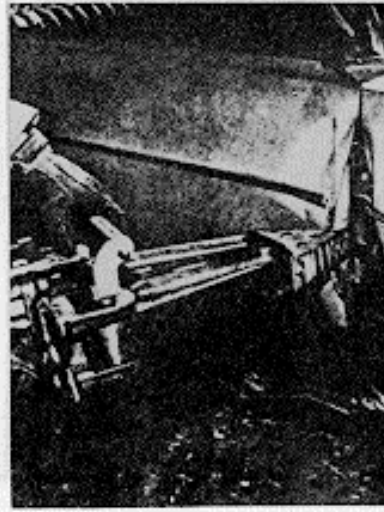

2

Operate the thumb control to open position, opening the jaws only wide enough to grab front edge of door. Close jaws and pinch the door edge. Rotate the tool and open the hinge side of the door.

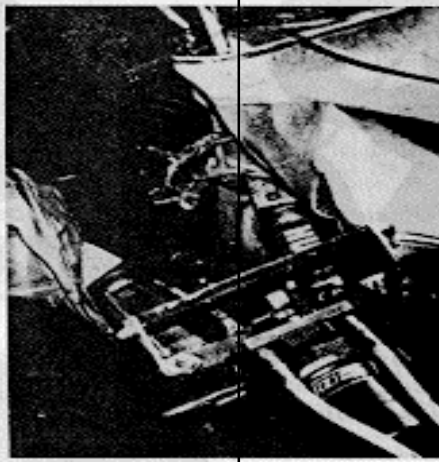

3

After opening the leading edge by pinch pry operation insert the jaws between the body of the car and the door above or below the hinge or lock. Move the operating thumb controls to the "open" position.

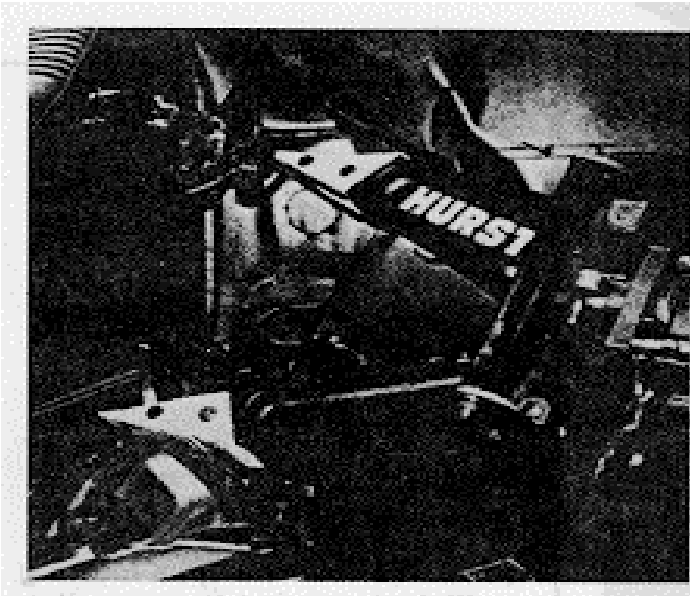

4

After the door is open, it may be completely removed by breaking the hinges repeating step 3.

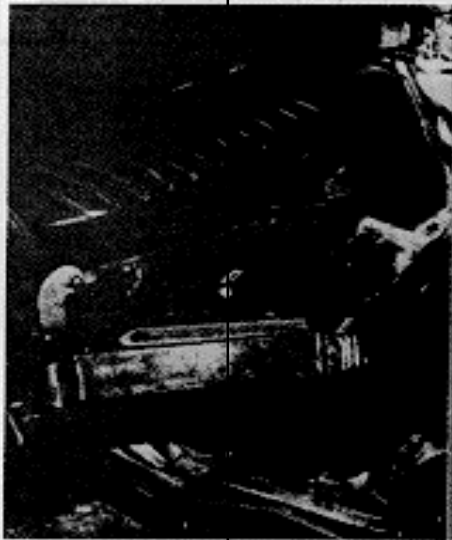
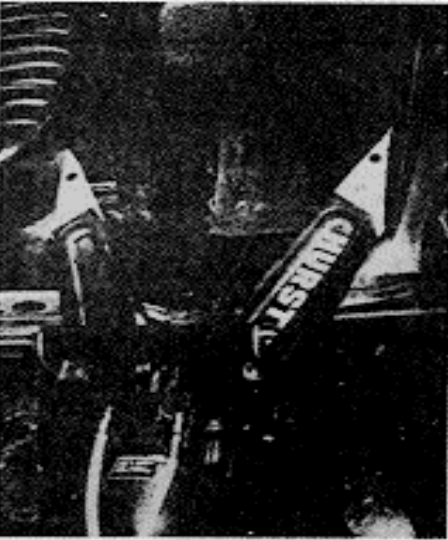

5

Assure additional access by pushing the front seat backward. Insert the jaws of the Rescue Tool between the front door frame and the front edge of the seat and open the Rescue Tool arms. Seat contact should be slightly lower than door frame.



# 6

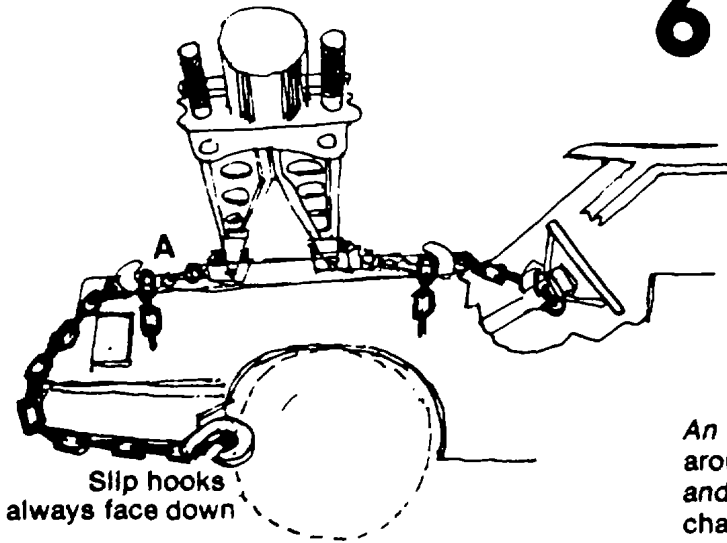
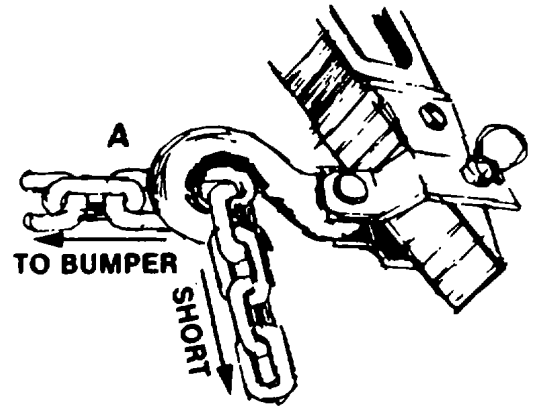

*An alternate method:* Fasten one chain around the steering column between wheel and shift level or the dash, and the other chain to the frame of car under bumper.

**7** a. Open tool to maximum spread.

b. Place shackles over ends of arms. Insert detent pins through shackles and holes in arms.

c. Wrap chain around steering column below steering wheel and shift level and fit slip hook attached to end of chain over chain. Insert opposite end of chain in grab hook at end of tool arm.

d. Attach another chain to body frame of car under bumper. Attach opposite end of chain in grab hook at end of tool arm.

e. Adjust chain length at grab hooks until all slack is removed from chain and the Rescue Tool is resting on the car hood.



# 8

Lift steering column by closing tool. If the steering column has not been pulled far enough from the victim when the tool jaws have fully closed, open jaws and shorten chain length by adjusting chain at grab hooks until slack has been removed. Reclose the tool to pull steering column out a greater distance from the victim.

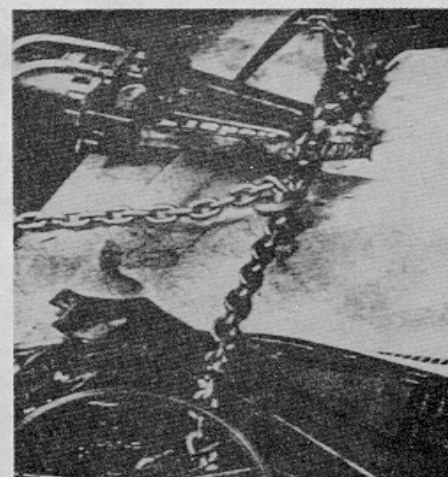
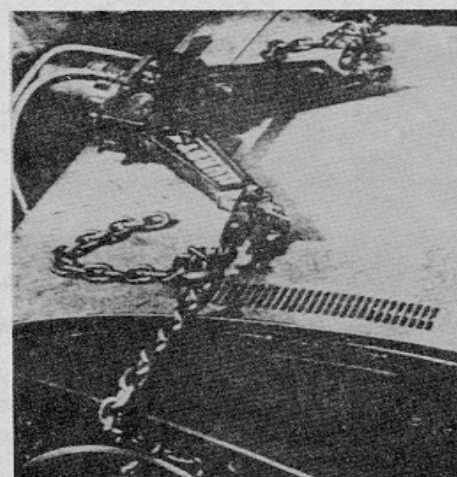



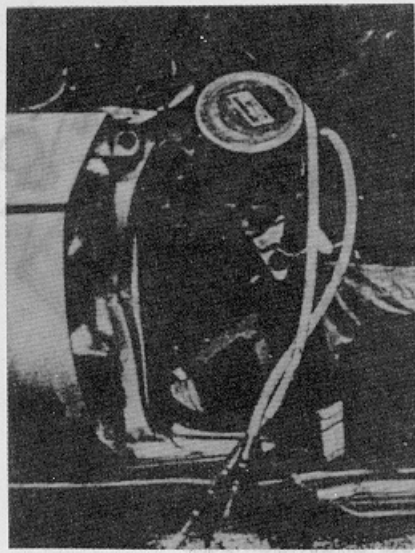

9

The steering wheel can be displaced several inches by pushing against the rocker panel and column from the inside

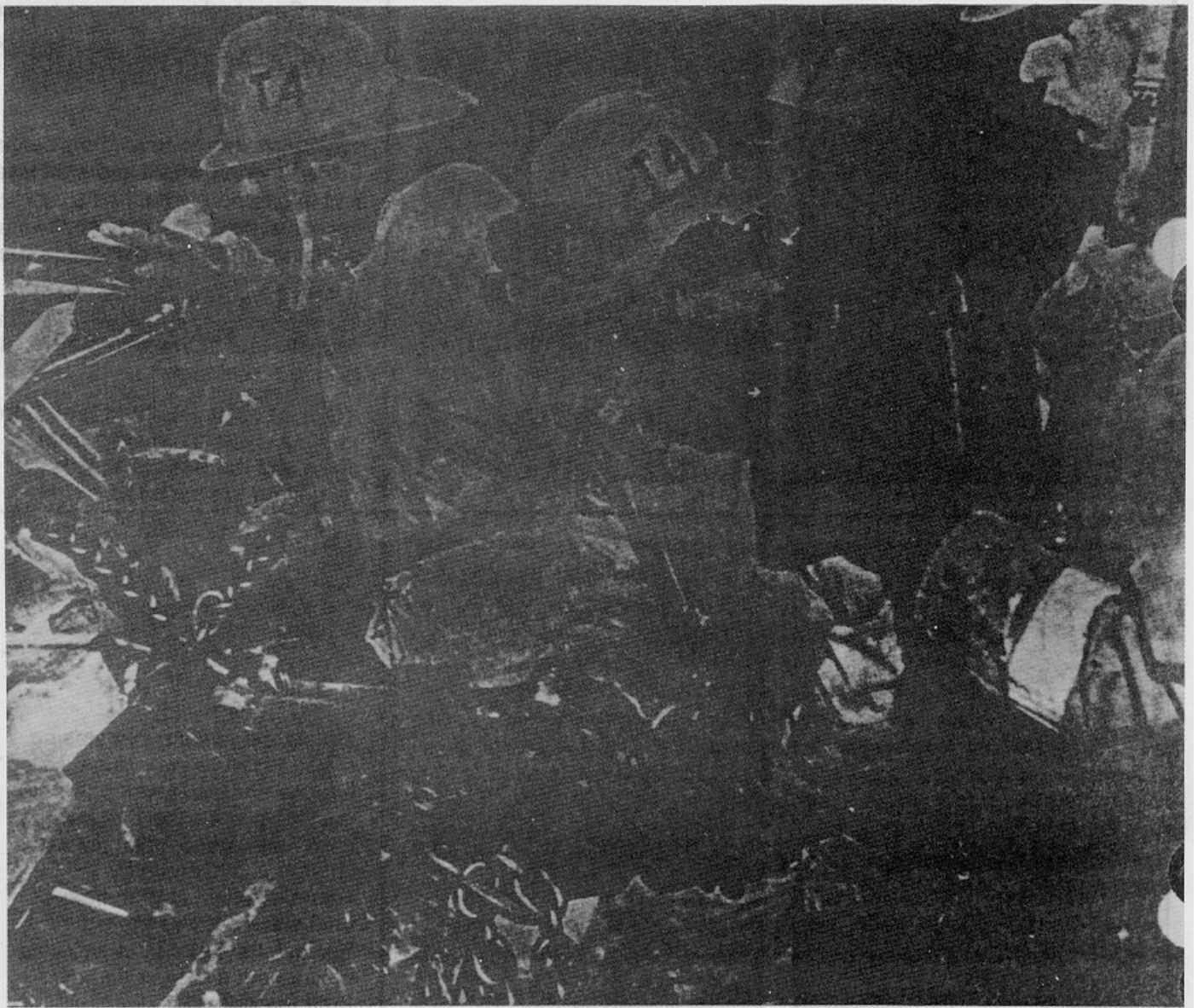

# 32100 HURST POWER RESCUE TOOL

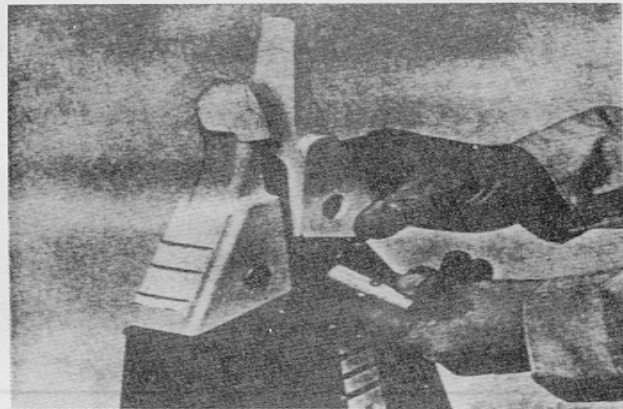

1

When cutting an access hold through metal with the Hurst Power Rescue Tool, remove the automotive spreading jaws and attach the cutting jaws. Attach the wide, smooth jaw on one arm and the narrow, concave jaw on the other arm. \* The tool will cut in the direction of the narrow jaw giving directional cutting.

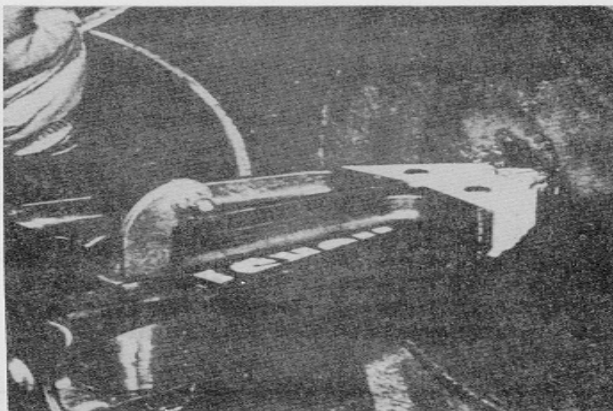

2

Pierce the material to be cut by using the weight of the tool to force the jaws to penetrate the metal. If more practical, any other piercing tool may be used for initial hole.

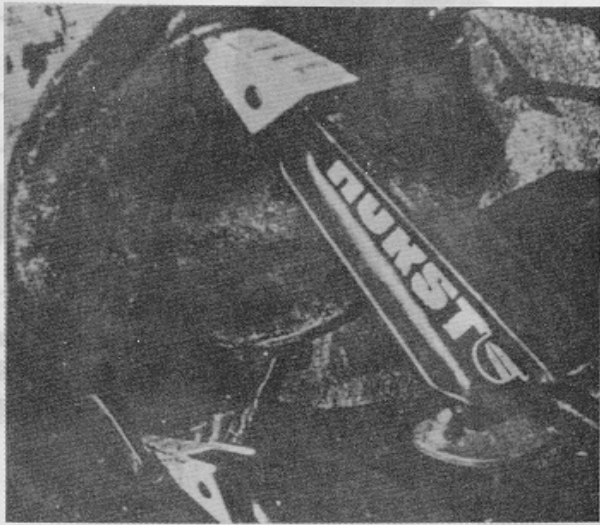

**3**

**Operate the thumb controls to the "open" position, spreading the**

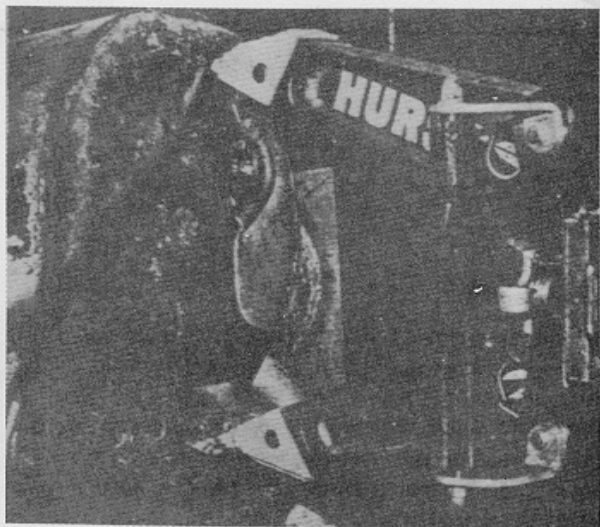

**4**

**Repeat this cutting procedure, opening the tool perpendicular to the first cut.**

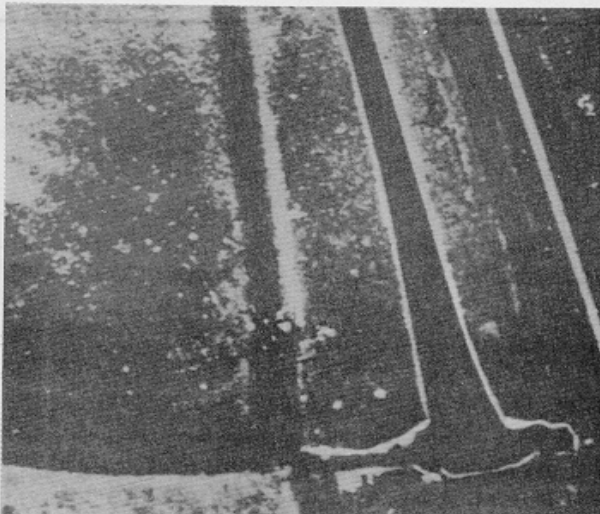

**5**

**This second cut will provide an "L" shaped cutout in the material to be opened. Remove the narrow cutting jaw and replace with the other wide cutting jaw.**

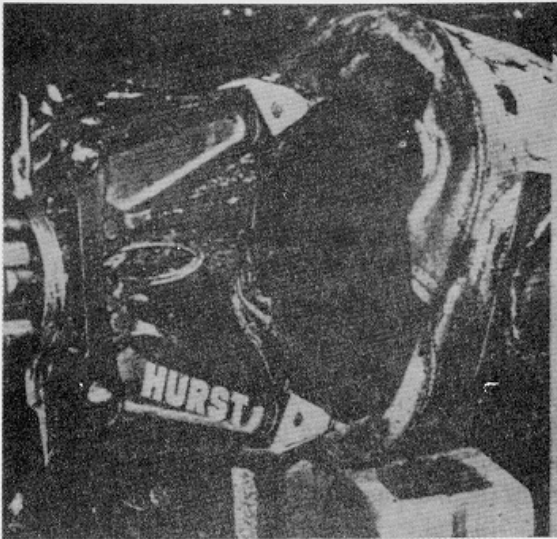

**6**

**Pry “open” resulting flap of metal. This opening should afford entry or exit.**

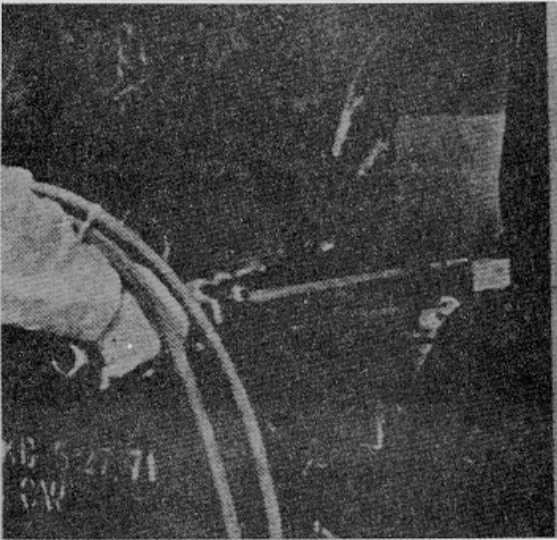

**7**

**When it is not possible to force the points of the Rescue Tool through metal, use any existing opening to start cutting with the Rescue Tool.**

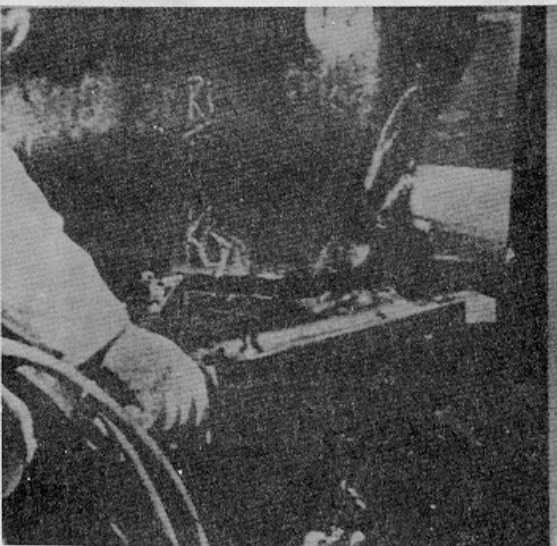

**8**

**Follow cutting procedures numbers 3 through 7.**



9

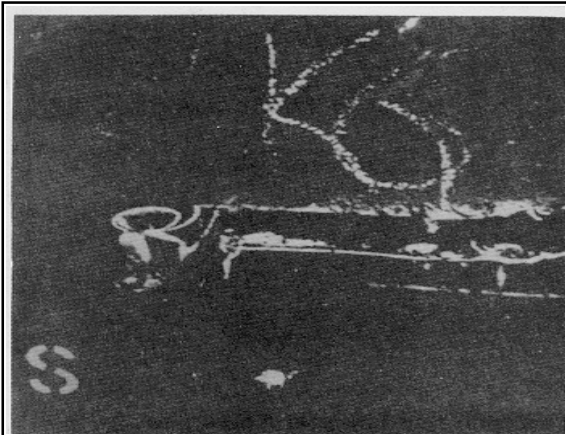

**NOTE:** Since the narrow cutting jaw has a concave face, the strip removed from the material cut with the Rescue Tool will be coiled.

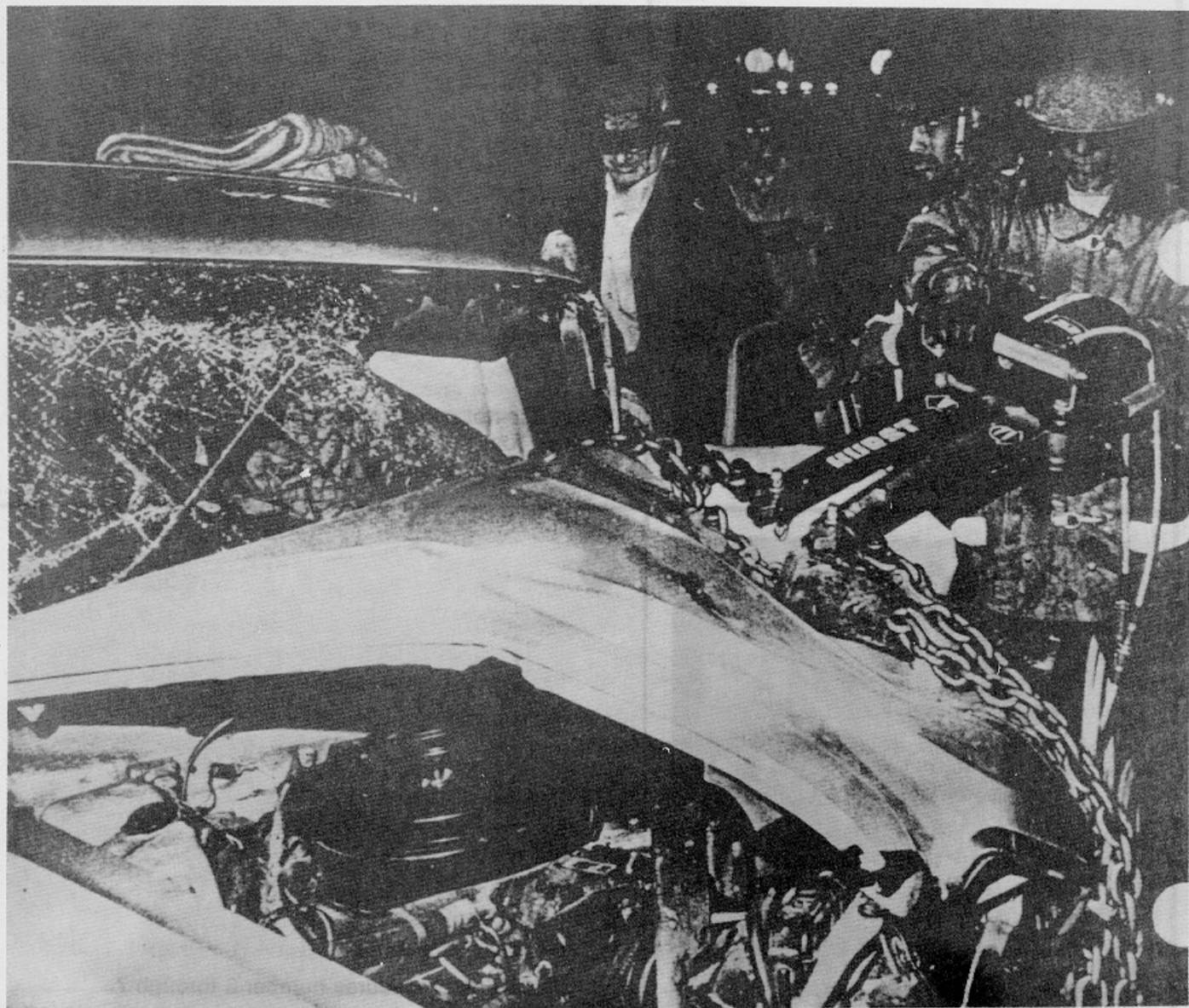

*Photo courtesy of Pat Olsen*

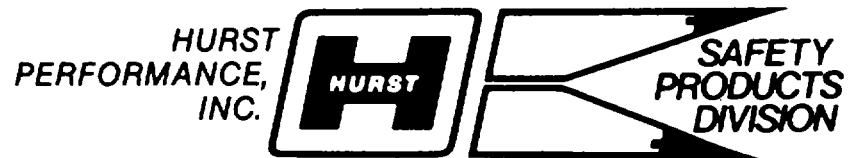

1957 PIONEER RD., HUNTINGDON VALLEY, PA 19006  
(215) 672-1700 • TWX 510-665-5425



**PRINTED IN USA • 159-R022 00 • 5M681 • PATENT PENDING**

Hurst Safety Products reserves the right to make changes at any time without notice or obligation in prices materials, equipment or specifications and to change or discontinue models. Check with distributor for current information.

**K1200**

**INSTRUCTION BOOK**

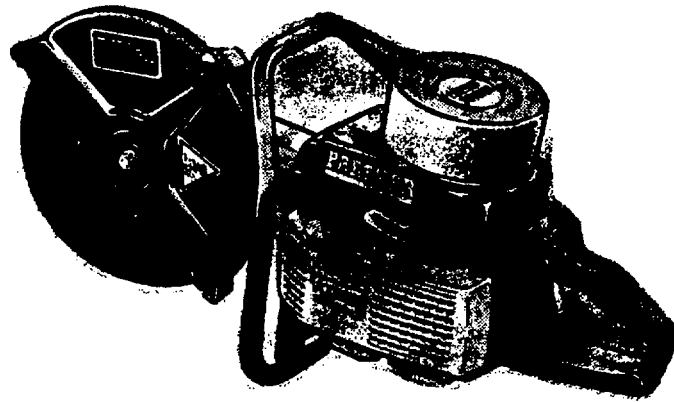

**Contents:**

Safety precautions.....	Correct starting position and starting of the saw.....
Identification .....	Starter unit.....
Fitting the cutter arm K1200.....	
Turning the cutter arm K1200 .....	Air filter K1200.....
	Carburetor .....
Cutter disc .....	Spark plug.....
Guard .....	Working technique .....
	Maintenance scheme .....
Vee-belt K1200.....	Tools .....
Fuel mixture.....	Technical data .....
Fuel tank.....	
Controls .....	

## Operator Safety Precautions

- 1 Never operate the machine when you are fatigued
- 2 Use safety footwear, snug-fitting clothing, safety goggles, and hearing- and head-protection devices and gloves.
- 3 Always use caution when handling fuel. Move the cutting machine at least 10 feet from the fueling point before starting engine.
- 4 Do not allow other persons to be near the machine when starting or cutting. Keep bystanders and animals out of the work area.
- 5 Never start cutting until you have a clear work area and secure footing. Always hold the unit firmly with both hands when the engine is running. Use a firm grip with thumbs and fingers encircling the handles.
- 6 Always hold the unit firmly with both hands when the engine is running. Use a firm grip with thumbs and fingers encircling the handles.
- 7 Keep all parts of your body away from the cutter disc when the engine is running.
- 8 Never operate without the disc guard.
- 9 Do not cock, wedge or jam the disc in the cut
- 10 Before starting the engine, make sure that the disc is not contacting anything
- 11 Always carry the machine with the engine stopped and the muffler away from your body.
- 12 Never operate a cutting machine that is damaged, improperly adjusted, or not completely and securely assembled. Be sure that the disc stops moving when the throttle-control trigger is released
- 13 Always shut off the engine before setting the machine down.
- 14 Keep the handles dry, clean, and free of oil or fuel.
- 15 Operate the machine only in well-ventilated areas. Failure to use the power cutter in a well-ventilated area can lead to serious injury or death.
- 16 The cutter disc should be removed from the cutting machine when it is transported or stored.
- 17 All service other than items listed in the machine builder's maintenance instructions should be performed by competent service personnel.
- 18 Do not operate a cutting machine unless specifically trained to do so.
- 19 For health reasons, never cut material containing asbestos.
- 20 When cutting concrete, stone, etc., sprinkle water to bind the dust

## Care of cutter discs

All cutter discs are breakable and, therefore, care shall be exercised in their handling and storage to prevent damage. Immediately after unpacking, all discs shall be closely inspected to make certain that they have not been damaged from handling, shipping or other causes. Cutter discs should be laid flat on a flat surface away

from excessive heat or moisture. Discs should not be stored subject to: exposure to high humidity, water, other liquids, or freezing temperatures. Discs used on machines on emergency vehicles should be dismounted after use and discarded or carefully stored as described in this section.



K1200

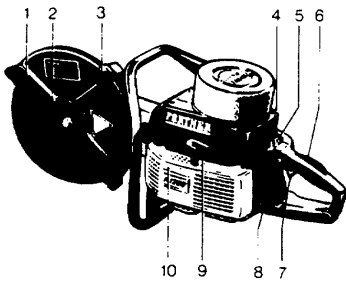

Pos. Description

1. Cutter disc
2. Guard
3. Knob for guard
4. Stop control
5. Choke
6. Idling catch
7. Throttle control
8. Starter throttle control
9. Starting handle
10. Starter unit
11. Lock nut for air filter
12. Air filter
13. Spark plug
14. Cylinder
15. Vee-belt
16. Cutting arm
17. Knob for guard

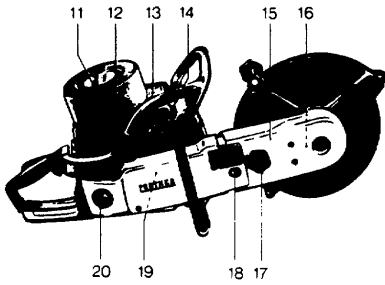

4150

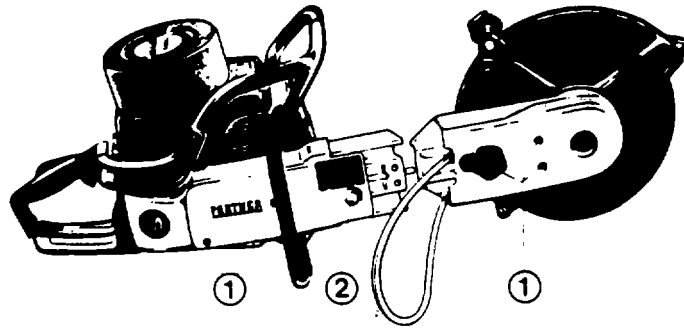

### Fitting the cutter arm K1200

Remove both the drive belt protecting casings (4 screws, knob and bushing) (1) Remove the attaching bolt (2) for the cutter arm

Fit the bolt on which the knob was placed in the upper hole in the arm and tighten the attaching bolt (2) by hand.

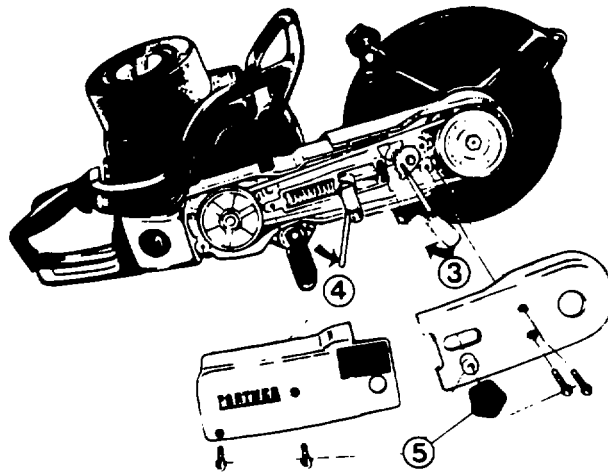

Fit the vee-belt and tension it by turning the eccentric (3) to its bottom position (clock-wise) using socket wrench 505381306. Tighten the attaching bolt (4) (anti)clock-wise) using socket wrench 505381317.

Fit the drive belt protective casings. the bushing and the knob (5) Tension the vee-belt after 1-2 tank refills and thereafter every day See the next page concerning turning the arm.

**K1200/K850**

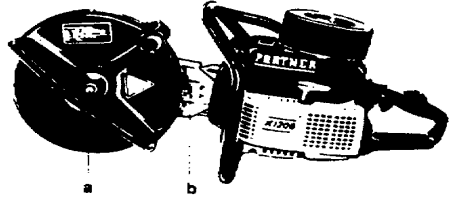

### Turning of the cutting arm

When the cutting arm is in its normal position, the cutter disc is held in position b) means of a screw with a right-hand thread (a) while the cutter arm attaching screw (b) has a left-hand thread. This facilitates cutting close to

The cutter arm is loosened in the same way as when changing the drive belt, see page 16. Loosen also the knurled knob and the screw retaining the stay. Turn the protective casing through 180°. Fit the drive belt on the engine and then on the cutter arm so that the screw on the stay fits into the lower hole in the crankcase.

**K1200/K850**

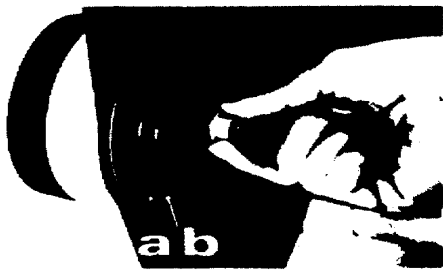
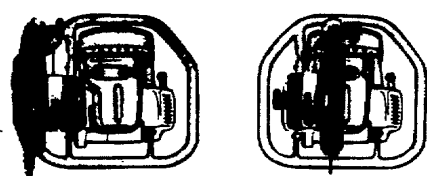

The disc is located between the flange hub (a) and the flange washer (b). Turn the flange washer round so that it fits into the flange hub. The cutter disc should be tightened by using the fixed wrench 505381317 that is included in the tool kit. Support the shaft with/ the spark plug wrench. The disc is to be

### Guard

#### **Never operate without the disc guard.**

The guard should be adjusted so that its rear section is close to the workpiece. Particles, dust or sparks from cutting are then collected by the guard and directed away from the operator. By using the knob the guard can be loosened and adjusted to the desired position.

### Vee-belt K1200

To stretch the belt, loosen the screw retaining the cutting arm by turning clockwise using the socket wrench included in the tool set and rotate the cutter disc a few turns by hand, When the screw has loosened slightly, stretch the belt by using the automatic belt tensioner.

### Replacing the vee-belt K1200,

To replace the belt, remove both the casings on the cutting arm Loosen the screw (at the arrow) holding the cutting arm

Turn the eccentric counter-clockwise by using the spark plug wrench so that the tension on the spring is released The cutting arm can then be pressed back and the belt removed

The belt tensioner consists of a powerful spring tensioned by turning the eccentric clockwise as much as possible The belt will then be tensioned by the spring power exactly as much as necessary.

A new belt should be tensioned after 1-2 refillings of the fuel tank Thereafter check the tension daily.

### Fuel mixture

The engine is lubricated by the oil in the fuel mixture.

### Petrol (gasoline)

1. Use "regular" petrol (gasoline). Premium grade is not necessary.

### Oil

1. For best performance use Partner-oil. Mixture ration 1:50 (2 %).
2. If no Partner oil is available, other two- stroke oil of good quality can be used Mixture ratio 1:25 (4 %).
3. Never use multi-grade oil (10W-30) or any oils formulated for 4-cycles engines. The petrol (gasoline) and the oil must be thoroughly mixed before being put into the fuel tank **Always shut the engine off before filling the tank.**

### Fuel tank

The fuel tank must be protected from Impurities when filling up with fuel. This decreases the risk of running Interruptions caused by blockage of the fuel tank filter. The filter cartridge cannot be cleaned but must be replaced if it becomes blocked This replacement should be done once a year.

### Controls

A Stop control. When the button is pressed backwards, the engine stops. The button remains in this position and must be returned to its initial position before the engine is started the next time.

B Choke button. A cold engine is to be started with the choke flap closed (the button pressed backwards). A warm engine is as a rule to be started without choke.

C Starter throttle catch. Press in the throttle control and thereafter the starter throttle catch. Release the throttle control and the throttle is blocked in half throttle position. The catch is released when the throttle control is pressed in all the way.

D Throttle control. The throttle control is used to regulate engine speed and the speed of the cutter disc.

E Idling catch. This catch will prevent the throttle from opening accidentally when the engine is at Idling speed. When working with the machine the catch is released by the hand holding the rear handle.

## **Starter unit**

### **Replacing the starter cord**

Loosen the fan casing. Pull out the starter cord a little and prevent the cord drum from rotating back. Place the starter cord in the recess and let the cord drum rotate back.

Loosen the lock spring and lift up the cord drum. Pull the new starter cord through the hole in the cord drum and further through the fan casing to the starter handle, where the cord is secured by a knot.

Attach the other end to the cord drum. Take up a few turns of the cord and fit the cord drum. Tension the starter spring by giving the cord drum one or two turns clockwise. Pull the starter cord to make sure that the starter unit functions before screwing the fan casing into position.

### **Air filter K1200,**

The air filter systems consists of a pre-filter (1), a main filter (2) and a spill filter (3) The spill filter may only be replaced by an authorized workshop.

The pre-filter can be changed without using any tools and is easy to clean. It protects the main filter from becoming blocked too quickly.

The pre-filter must be pulled off and shaken clean in connection with every tanking operation. The pre-filter should be thoroughly washed or replaced after 30 hours of operation in steel material or after 20 hours of operation in concrete or similar material which gives rise to intensive dust.

Remove the main filter by loosening the nuts retaining the filter housing and lifting off the housing. The main filter is a paper unit of a special quality grade which must not be washed or blown clean. **The filter may only be shaken** clean. Washing, blowing clean or attempts to clean the filter by using tools damage it to such an extent that it is ruined.

When cutting steel, change the filter after about 60 hours of operation and when cutting concrete after about 40 hours of operation. More frequent changing should be carried out when working under more severe conditions.

**NOTE! Incorrect servicing or neglect to change the pre-filter and main filter at the specified intervals can result in engine break-down.**

### **Carburetor**

When delivered from the factory the carburetor is basically set. This means about 1/4 turns open on both the high-speed screw (H) and the low-speed screw (L). The idling screw (t) is to be screwed in 1/2 turns after contact with the throttle shaft lever. After the saw has been run warm the carburetor is ready for fine adjustment. The low-speed screw (L) is to be set so that the engine does not stop at idling speed. The high-speed screw (H) is to be set so that the engine runs well at full

### **Replacing the starter spring**

Follow the same procedure as described above for replacement of the starter cord. Then loosen the screw holding the spring cassette to the fan casing.

Place the eyelet of the spring into the cord before the fitting. In order to guarantee dependable functioning of the starter unit, the cord drum bushing and the starting hooks should be lubricated with silicon oil or similar lubricant at least once a month.

### **Correct starting position and starting of the machine**

Due to the setting of the throttle, the disc will start to rotate as soon as the engine fires so be sure that you and the machine are firmly positioned when starting. Pull the starter cord out smartly a few times until the engine starts.

### **Removing the spark plug, K1200/K850:**

Loosen three screws retaining the cylinder casing. Then lift off the cylinder casing together with the air filter. Loosen the spark plug by using the socket wrench in the tool kit.

speed. Then open the screw 1/4 turns. The carburetor is fitted with an excess speed governor to prevent excessively high engine speed, which would result in the cutter disc turning too fast. At full speed and with unloaded disc you can hear clear variations of the engine speed. This is normal and only a sign of the fact that the speed governor is working. The idling screw (t) is set so that the engine runs at idling speed without the disc rotating.

The following is a summary of various measures mentioned in the book and which is essential for the correct servicing of the cutting machine. The time intervals mentioned should be applied if the cutting machine is used for at least 4 hours every day. If the machine is used for a shorter time each day, the shortest intervals can be extended without any ill effects.

Unit on cutter	Operation	Frequency
Guard	Check function	always
Controls	Check function	always
Starter unit	Clean and lubricate moving parts	every month
Air filter		
Pre-filter	Shake clean	at every tanking operation
Main filter	Clean - replace	see page 25 and 27
Spill filter	Clean - replace	by authorized workshop
Carburetor	Check, adjust	when necessary
Spark plug	Check and adjust electrode gap	when necessary
	Replace	every other month
Engine	Clean cooling vanes	every other week
Vee-belt	New belt to be tensioned after thereafter check belt tension	1-2 refillings daily
Fuel tank	Replace filter cartridge	at least once a year
Screws, bolts and nuts	Check tightening	every week

**Tools**

**K1200/  
K850**

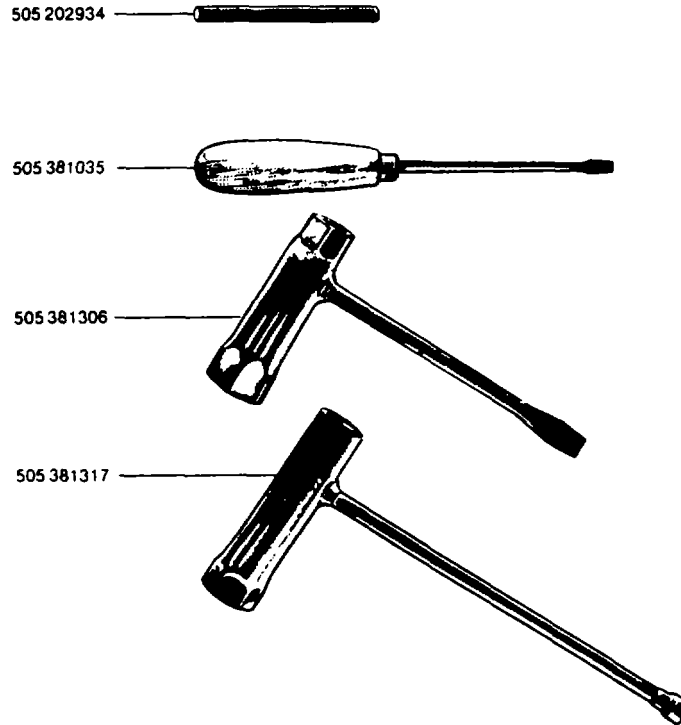

## Technical data

### Engine

air-cooled, two-stroke  
capacity

### K1200

100 c.c

### Ignition system

transistor Ignition system  
spark plug  
electrode spark gap

Electrolux  
Champion CJ7Y  
0.8 mm (.031")

Tilloston HS-175 B  
9.600 ± 400

### Carburetor

speed governor  
range of regulations

4% (1:25)  
2% (1:50)  
1.0l (1.76 Imp. pints -  
2.12 US pints)

### Fuel

oil mixture ratio  
with PARTNER oil  
tank capacity

## CUTTING EQUIPMENT

### Cutter disc

12" (K1200)

### Gear ratio

1:17

### Max. peripheral speed

100m/s      100m/s

# Operator's manual

For the safe and efficient use of your  
cut-off saw





<b>Table of contents</b>	<b>Page no.</b>
<b>Foreword</b> .....	4159
<b>Part of the Cut-Off Saw</b>	
Gasoline .....	4161
Electric 4162	
<b>The. Operator</b>	
Physical condition .....	4163
Personal Safety Equipment.....	4163
<b>Checking the Cut-Off Saw Before Use</b>	
Attachment .....	4164
Drive Shafts & Flanges.....	4164
Cutter Wheel .....	4164
Cutter Wheel Size .....	4164
Reducing Bushings.....	4164
Blotters 4164	
Securing the Cutter Wheel .....	4164
Guard.....	4164
V-Belt/Belt Covers .....	4165
Handles .....	4165
Vibration Isolating Elements.....	4165
Air Filter 4165	
Controls .....	4165
Cooling Passages .....	4165
General 4165	
<b>Cutter Wheels</b> .....	4166
Abrasive.....	4166
Areas of Use	
Masonry.....	4166
Metal Wheels.....	4166
Special Wheels.....	4167
Care and storage of.....	4167
Inspection .....	4167
Bursting Wheels .....	4167
Diamond blades .....	4167
Design .....	4167
Characteristics.....	4168
Cooling of .....	4168
Direction of Rotation.....	4168
Protecting your Investment.....	4169
Carbide Tipped Blade.....	4169
Special Safety Precautions.....	4169
<b>Putting the Cut-Off Saw Into Use</b> .....	4170
Fueling.....	4170
Starting .....	4170

Guard.....	4171
Cutter Wheel .....	4171
Working Technique .....	4172
Wet Cutting.....	4172
Sharpening of the Wheel.....	4172
Vibrating Wheels .....	4172
Reactive Forces .....	4172
Kick-back .....	4173
Pull-in.....	4174
Pinching/Rotation .....	4174
Muffler and Exhaust Gases .....	4175
Maintenance	4175
<b>Safety Regulations .....</b>	<b>4176</b>

**Foreword**

Cut-off saws have proven themselves to be very useful and versatile for many jobs - from everyday industrial work where the saw facilitates and makes possible certain jobs, to dramatic rescue work where cut-off saws can save lives. The following Instructions are intended to provide guidelines and advice with respect to the use and handling of the cut-off saw with the accent on safety. The instruction book and the workshop manual provide detailed technical information for each individual model.

Due to their special importance, certain sections of this book have been highlighted. However, that does not mean that the remaining text is less important and can be ignored. All instructions should be carefully read and understood. Do not hesitate to call your dealer if you do not fully understand the text or if more information is needed. Since safety regulations can vary between different countries and states, you must always contact the local authorities and carefully follow their regulations.

This manual covers both gasoline and electrically powered cut-off saws. When an instruction only applies to one of the two, that will be indicated by a "G" (gasoline) or "E" (electric). All repair work, over and above routine servicing specified in the instruction book, may only be carried out by an authorized service workshop. For safety reasons, only genuine parts should be used for repair purposes.

**Under no conditions may a cut-off saw be modified from its original design except with the permission of the manufacturer in writing. Non-authorized modifications can lead to serious injury or death to yourself or others.**

**ELECTROLUX MOTOR**

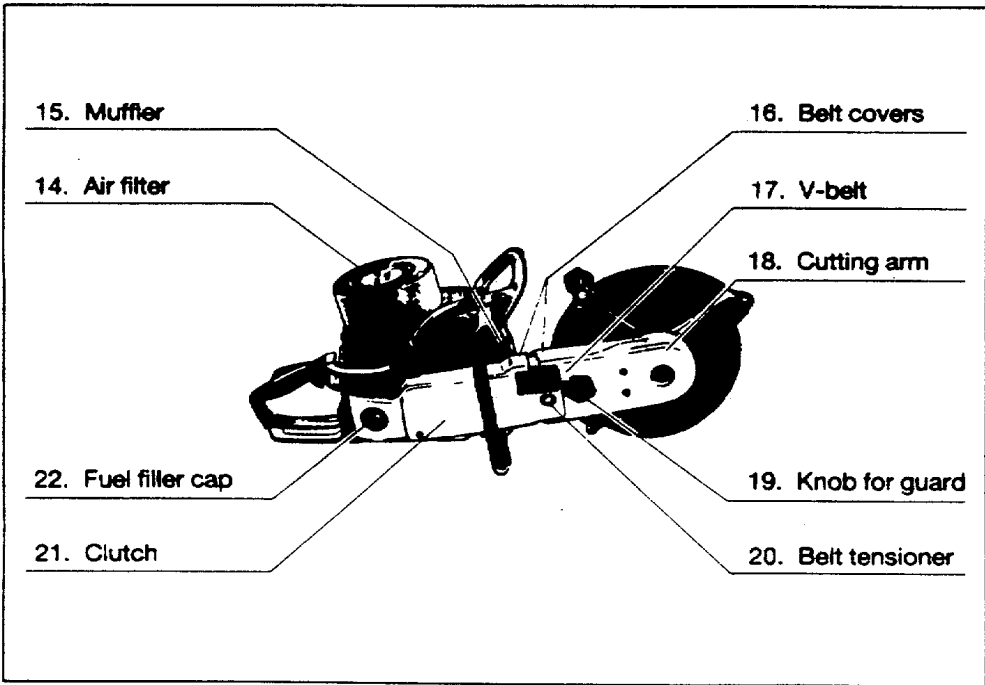
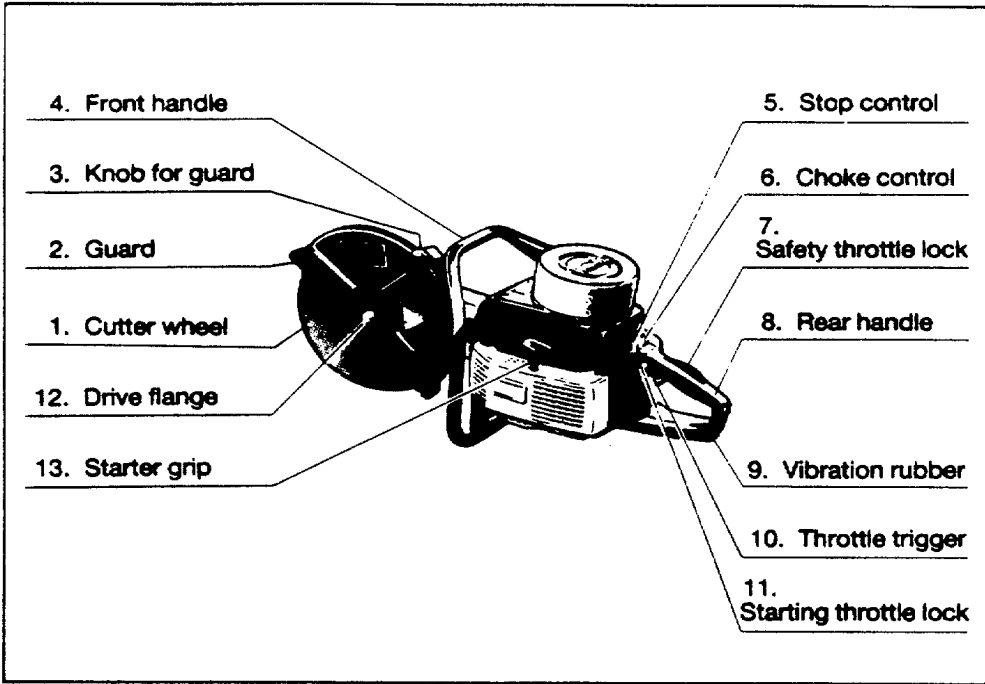

## Parts of the cut-off saw

### GASOLINE POWERED CUT-OFF SAW

#### Definition:

1. **Cutter wheels.** Are available in three major types: abrasive wheels, diamond blades, and carbide-tipped blades.
2. **Guard.** Provide protection against sparks and particles thrown off when cutting.
3. **Knob for Guard.** Together with 17, the knob locks the guard in position. To adjust the guard, knob 3 and 17 have to be loosened.
4. **Front handle.** Handle bar for the left hand at the front of the saw.
5. **Stop Control.** Lever for stop control. When lever is pulled backward, the engine stops.
6. **Choke control.** Lever for choke control. When lever is pulled backward, the engine is choked. (Starting position, cold engine.)
7. **Safety Throttle Lock.** Must be depressed before the throttle trigger can be activated. Prevents accidental acceleration.
8. **Rear Handle.** The support handle for the right hand. Incorporates throttle trigger and safety throttle lock.
9. **Vibration Rubber Elements.** Isolate the handles from the vibrations of the engine.
10. **Throttle trigger.** Controls speed of the engine.
11. **Starting Throttle Control.** To be activated when starting a cold engine. Is released when the throttle trigger is pressed.
12. **Drive Flange.** Transmits the torque from the drive shaft to the cutter wheel.
13. **Starter Grip.** The grip of the pull starter which is the device to start the engine.
14. **Air Filter.** Cleans the incoming air to the cylinder.
15. **Muffler.** Attenuates exhaust noises and diverts exhaust gases in the required direction.
16. **Belt Covers.** Protects the operator from getting caught in the V-belt as well as protecting the belt from dust and water.
17. **V-belt.** Transmits the power from the engine to the cutter wheel. (Not Illustrated.)
18. **Cutting Arm.** Attaches the cutting equipment to the power head.
19. **Knob for Guard.** Together with 3, the knob locks the guard in its position. To adjust the guard, knob 3 and 17 have to be loosened.
20. **Belt Tensioner.** Should be loosened to adjust the belt to proper tension.
21. **Clutch.** Couples engine to drive wheel when engine is accelerated beyond idle speed (not Illustrated).
22. **Fuel Filler Cap.** For closing the fuel tank.

#### Note:

Different models may have different parts and controls.  
See your specific model Instruction Book for details.

PAGE 4162 DELETED

## **The Operator**

### **Physical Condition**

Never use a cut-off saw without having received Instructions for its use. If not handled properly and with care, a cut-off saw can be a dangerous tool. Operation of a cut-off saw should be restricted to mature, properly Instructed adults. Don't work when tired under stress, fatigue or under the influence of medicine, drugs or alcoholic beverages. Be alert, If you get tired while operating the cut-off saw, take a break. Tiredness may result in loss of control.

### **Personal Safety Equipment**

Clothing must be sturdy and snug-fitting but allow complete freedom of movement. Protect your hands with gloves. Heavy duty, non-slip gloves improve your grip and protect your hands.

Good footing is most important. Wear sturdy boots with non-slip soles. When working with a carbide tipped blade, steel toed safety boots shall be used.

Proper eye protection is a must. Use approved goggles or full face shield. Wear approved helmet to protect your head. Hearing protectors are recommended if the cut-off saw is to be used over an extended period of time (more than 30 minutes per day).

A breathing mask should be used if you are cutting material which gives rise to a large amount of dust.

Leg protectors can protect your clothes from burns by sparks generated when cutting steel.

### **Checking the cut-off saw before use**

#### **Checking the cut-off saw before use**

Competent persons shall be assigned to the inspection and care of the cutting-off machines. Such persons shall be fully instructed in the use, care, and protection of the machines as defined in this manual.

### **Attachment**

**Never modify a cut-off saw in any way. Only attachments supplied by Electrolux Motor or expressly by approved by Electrolux Motor for use with a specific cut-off saw are authorized. Although certain unauthorized attachments may be usable with the powerhead, their use may, in fact, be extremely dangerous.**

The following inspections should always be carried out on the saw before it is to be used.

### **Drive Shafts and Flanges**

The drive shaft must be checked to ensure that its threads are not damaged. The contact surfaces on the cutter wheel and flanges must be flat, run true on the arbor, and be free from foreign objects. Do not use flanges that are of different size, warped, nicked, sprung or not clean.

### **Cutter Wheel**

Check that the wheel you intend to use has been approved for hand-held portable high speed cut-off saws and that the maximum operating speed established for the wheel is

**PAGE 4162 DELETED**

not exceeded by the cut-off saw. Immediately before installation, all wheels shall be closely inspected to make sure that they have not been damaged in transit, storage, or otherwise. Cracked wheels or wheels that show any evidence of abusive handling or storage shall not be used.

Apart from visual inspection, the following test can be used for abrasive wheels. Support the wheel at the center hole and knock lightly with a piece of wood on the side of the wheel. **If there is no ring to the noise, or if the noise sounds cracked, then the wheel is damaged in some way and may not be used. Do not use a wheel that has been dropped. The impact may result in breakage.**

A diamond or carbide-tipped blade which has lost one or more of its segments (tips) may not be used. Do not discard such a blade. In many cases, it can be repaired. Contact your dealer for more information.

### **Cutter Wheel Size**

Never use a cutter wheel that is larger than the size for which the guard is dimensioned. The cutter wheel must rotate freely under the guard and must not chafe anywhere.

Cutter wheels are normally available in three different sizes of arbor holes (the center hole in the wheel): 20 mm, 7/8" (22.2 mm), and 1" (25.4 mm). The hole and the drive shaft must match each other.

There must be a tolerance of 0.2 mm (.010 inch) between the drive shaft and the cutter wheel's center hole in order to avoid the wheel being subjected to any thrust forces in connection with assembly. If the wheel fits too loosely on the arbor, it can become badly out of true and will noticeably "pound". **Do not force a wheel onto the cut-off saw or alter the size of the arbor hole. Do not use a wheel that fits too tight or too loose.** If the wheel doesn't fit the cut-off saw, get one that does. It is also possible on cut-off saws to change the size of the arbor or to use a reducing bushing.

### **Reducing Bushings**

If a reducing bushing is used in the cutter wheel's center hole, it must not be wider than the thickness of the cutter wheel and must not come into contact with the flanges. Loose reduction bushings, which are not retained in position mechanically, should not be used together with cutter wheels which are thinner than 3 mm (1/8"). Only an appropriate reducing bushing may be used to compensate for an oversized hole.

### **Blotters**

Mounting of cutter wheels should incorporate the use of blotters. They should be made of highly compressible material such as blotting paper, and should not exceed 0.5 mm (.020") in thickness.

### **Securing the Cutter Wheel**

Be sure the flanges are tightened sufficiently to drive the wheel and to prevent slippage, but not too tightly to avoid springing the flanges and changing the pressure area.

### **Guard**

The guard must be inspected for cracks or other forms of damage. During wet cutting in concrete, the inside of the guard can become clogged by concrete dust. Similar build-up can take place when cutting asphalt or tar paper. The deposits must be removed before a new wheel is installed. Check that the guard moves easily and the locking mechanism functions so that the guard can be moved to different positions and securely locked. Always have the guard properly adjusted to the work you intend to carry out

**V-belt/Belt Covers (G)**

Keep the V-belt properly tensioned. Too loose or too high tension will drastically reduce the life length of the belt. Always protect yourself and the belt by having the belt covers properly mounted. Fingers and/or clothing can get caught in an exposed belt; and as a result, an injury can occur. The covers also protect the belt from exposure to dust, water and other impurities. The protection will increase the life length of the belt.

**Handles**

Check that handles are well tightened and not cracked. Keep the handles dry, clean and free from fuel and oil.

**Vibration Isolating Elements (G)**

The rubber elements may not be seared or noticeably damaged by exposure to fuel and oil. **Damaged vibration elements impair the control of the cut-off saw and may cause you to lose control while working.**

**Air Filter (G)**

A clean air filter gives the engine more power and reduces the fuel consumption. Clean prefilter every time when refueling.

**Controls (G)**

The throttle control must move freely. The carburetor must be adjusted so that idling speed is below clutch cut-in speed. With the wheel off-load and the throttle fully opened, the speed of the cutter wheel must not exceed that in the recommendation.

When pulled backward the stop switch must stop the saw. The safety throttle lock may not be put out of service by taping it down or through any other means.

**(G.E.) Non-working controls imply a safety hazard. You must not run the saw unless all controls work properly. If necessary, have the saw adjusted by an authorized workshop.**

**Cooling Passages**

Keep all cooling passages and cylinder vanes (G) free from deposits. Clean passages mean lower engine temperature and longer life.

**General**

Check power head and the cutter arm for wear and cracks. Check that all the screws are well tightened. Regular maintenance must always be carried out in accordance with the instruction book for each individual model.

## **Cutter Wheels**

Cutter wheels are available in three basic types: abrasive wheels, diamond blades and carbide-tipped blades. Electrolux Motor branded wheels and blades are specially manufactured for hand-held portable high speed cut-off saws. If another manufacturer's wheel is used, you must make sure the wheel meets all regulations and standards relating to this kind of hand-held portable high speed equipment. **Under no circumstances may the maximum operating speed established for the wheel be exceeded.**

**Certain wheels for special purposes are available which meet the peripheral speed requirements but may not be used for HAND-HELD PORTABLE HIGH SPEED CUT-OFF SAWS. Such wheels may only be used in stationary equipment. They may be used together with attachments such as the rail cutting attachment- However, in cases like this, you should always contact your local authorities to make certain that you follow regulations and standards which pertain to your area.**

## **ABRASIVE WHEELS**

The cutting material in abrasive wheels consists of abrasive grains held together by organic bonds. The term reinforced as applied to cutting-off wheels defines a class of organic wheels which have webbing fabric or filament that provides resistance to total breakage at the designated maximum operating speed should the wheel become cracked or damaged. The term reinforced does not apply to wheels which have webbing fabric or filament around the flange area only.

The wheel's performance is determined by:

Type of grinding particles

Size of grinding particles

Type of bonding material

Hardness of bonding material

An operating condition which causes a wheel to have shorter life and faster cutting rate is said to make the blade act softer. A blade with longer life and slower cutting rate is a harder acting blade.

Choice of abrasive wheel should be made according to the best wheel economy. Low priced wheels often have a poor cutting capacity and a short life expectancy. Due to that, their cost per square inch of cut material is very high. The best economy is usually achieved when a high-quality wheel is used.

## **Areas of use**

### **Masonry Wheels**

Can be used to cut concrete, asphalt, stone, masonry, cast iron, aluminum, copper, brass, cables, rubber, etc. This type of wheel is a good all-around wheel with good economy. It can, for example, be used in reinforced concrete with a high content of steel. Water spraying of the wheel during work to decrease dusting is recommended and will increase the life length of the wheel.

### **Metal Wheels**

Intended for steel, steel alloys and other hard metals. Without competition in this area. The wheel performs poorly in concrete or similar masonry material. Water spraying will decrease the cutting capacity and is not recommended.



### **Special Wheels**

If your work requires a lot of cutting in the same material, it is often economical to get a wheel that has been specially designed for that kind of material. An example is the rail cutting wheel. This wheel has been specially designed for the quality of the rail material. It provides good life length and high cutting speed. A standard wheel for metal will also cut the rail but much slower and with poor economy.

### **The Care and Storage of Abrasive Wheels**

Great attention must be paid to the care and storage of abrasive wheels in order to prevent them from being damaged during handling. Thin, abrasive wheels with organic bonding agents must be stored on a level, firm surface and must not be subjected to heat or moisture. If an abrasive wheel is delivered with a fitted cardboard blotter, then a suitable spacer must be placed between the wheels to keep them flat. Abrasive wheels must not be stored in such a way that will expose them to high air humidity, moisture, other fluids or temperatures below the freezing point. Avoid storage at such low temperatures which can result in condensation on abrasive wheels when they are moved from storage to the working site. After the work has been completed, the wheel should be removed after its use and properly stored. If the wheel remains on the cut-off saw, there is a great risk for wheel damage during transport.

### **Inspection**

Immediately after a pack has been opened, all the abrasive wheels in the pack should be thoroughly inspected in order to determine that they have not been damaged during transport, storage or in any other way.

### **Bursting Wheels**

Abrasive wheels for use on hand-held portable high-speed cut-off saws belong to a class of extremely strong wheels which are difficult to break under normal conditions. If an abrasive wheel has failed (burst), a thorough investigation must therefore be carried out by the operator to determine the cause of the breakdown so it does not need to happen again. If more assistance is needed, the abrasive wheel manufacturer or the cut-off saw manufacturer must be contacted. Since the more common causes of wheel breakage have been traced to use of wrong wheel, improper mounting, improper speeds, abusive operation, and/or careless handling of the saw or of the wheel, proper and regular maintenance, service and inspection procedures obviously are of great importance in preventing wheel breakages. Regular inspection and maintenance procedures must, of necessity, be the responsibility of the user.

### **DIAMOND BLADES**

Used properly, the diamond blades provide both better performance and economy. The diamond blade gives good cutting economy in all masonry materials. Its high cutting capacity also makes the diamond blade suitable for work in reinforced concrete where the blade economy with an abrasive wheel is less beneficial. Normally diamond blades shall-not be used for metal cutting.

### **Design**

In principle, diamond blades have the same composition as an abrasive disc. Industrial diamonds are held together by a bonding material. Initial cost of a diamond blade is primarily dependent on the diamond content. A popular misconception is that diamond content and performance are directly proportional. This does not always hold true. In

practice, there are an optimum number of diamond particles of a specific grit size in a specific metal bond which will provide optimum performance for a specific application. On many applications, lower cutting costs are obtained by using lower, rather than higher, diamond concentration which, in some cases, will not cut at all.

### Characteristics

Compared to an abrasive wheel, a diamond blade has the following features and benefits.

#### Features

Less cost per cut compared to using abrasive wheels

Faster cutting than abrasive wheels

Substantially reduced number of blade changes compared to abrasive wheels

Diamond blade maintains constant depth of cut

Less dust than high-speed abrasive wheels

#### Benefits

Reduced material and labor costs for the contractor

Less time spent cutting  
Reduced labor costs  
Less operator fatigue  
Increased productivity

Eliminates wasted labor and time  
Increased productivity

Eliminates waste caused when abrasive wheels are thrown out before they are completely worn out  
Increased profits

Improved working conditions

### Cooling

Heat is the number one enemy of a diamond blade. If the heat becomes too high, the joints may melt, and the segment will be thrown away with great force. **This implies a safety hazard which may result in possible injuries.**

Cooling the blade through continuous water sprinkling increases the life expectancy of the diamond blade considerably. This is also true for blades designed for dry cutting. The life length for dry cutting blades can be extended if the work is executed in short cycles where the blade is given an opportunity to cool off somewhat between the work cycles.

This is especially true when working in hard materials. To cool the blade periodically by sprinkling water on the blade must be avoided as rapid changes in temperature will shock the diamonds and lower the life of the blade.

### Direction of Rotation

Most diamond blades must run in a specific direction of rotation. Look for an arrow stamped in the blade. If the blade is run in the opposite direction, the blade may be ruined.

### Protect Your Diamond Blade Investment

Your diamond blade will be a good investment only if you take care of it.

Do not run the blade in the wrong direction.

Do not bump the blade into the workpiece.

Do not wedge the blade in the cut.

Do not force a blade that has lost its cutting ability. Have it resharpened. See page 16.

Do not cool by periodically springling with water. You will only shock the diamonds.

Do not keep the blade on the saw during transport. It may be damaged.

Do cool the blade by constant water spraying.

### **CARBIDE-TIPPED BLADES**

Abrasive wheels and diamond blades work primarily through an abrasive action. The carbide-tipped blade has carbide tips brazed to a blade of steel. The cut material is carried away in a cutting action rather than an abrasive action. The blade is suitable for cuts in aluminum, sheet metal, etc., or when you need to cut many different materials at the same time. It is primarily used for rescue work when speed is important, and you have to quickly open an airplane body or make an opening in roofs and doors in fire fighting. It should only be used by specially trained and educated personnel who are familiar with the operation of carbide-tipped blades.

Due to its design, the blade can throw large particles of the work piece a long distance. If the blade is forced into the material too fast or if the material suddenly changes hardness; e.g., a heavy nail embedded in a wooden beam, one or more of the tips can come loose. This can happen during normal operation. Those tips or particles from the work piece will be thrown away with great force. If such a tip were to hit an unprotected eye or other exposed part of the body, severe injury could result.

This type of blade is more subject to kick back than other cutter wheels. Please refer to Page 16 for more detailed information about this safety hazard.

Local regulations in certain areas prohibit the use of carbide-tipped blades except when used under special circumstances such as fire fighting or other rescue operations, and no other means are available. Check with your local authorities to conform with all regulations.

### **Special Safety Precautions**

When using a carbide-tipped blade, the following safety precautions must be followed in conjunction with those mentioned elsewhere in this manual.

1. Only personnel who have received special instruction in the use of carbide tipped blades shall operate the cut-off saw.
2. The carbide-tipped blade shall only be used when the situation warrants such use.
3. The operator must use a helmet with a full face shield.  
We also strongly recommend approved safety goggles to be used in conjunction with the face shield. Steel toed safety boots shall be used.
4. All personnel assisting the operator must use the same protective equipment.
5. All bystanders not equipped according to (3) above, must be kept at a safe distance as they can be exposed to thrown-away particles. The safety distance should not be less than 30 m. (100 feet).
6. Beware of kick back. Hold the saw firmly with both hands, and encircle fingers around grips, wrapping thumbs on the opposite side from fingers.
7. Special attention should be given to the starting procedure. See Page 14.
8. Do not touch a rotating blade.
9. Carbide tipped blades may only be used on cut-off saws equipped with a slipping clutch.

## Putting the cut-off saw into use

Before the machine is started, the necessary safety checks must be carried out. See Page 7. After ensuring that the saw and the cutter wheel are in good condition and that the maximum cutter wheel speed is not exceeded at full throttle, off load, the saw can then be used.

### Fueling (G)

Your gasoline driven cut-off saw uses an oil/gasoline mixture for fuel. Please refer to your instruction book.

**Gasoline is an extremely flammable fuel. Use extreme caution when handling gasoline or fuel mix. Do not smoke during fueling or bring any fire or flame near the fuel.**

Fuel your cut-off saw in well-ventilated areas, outdoors only. Always shut off the engine and allow it to cool before refueling. Relieve fuel tank pressure by loosening fuel cap slowly. Select bare ground for fueling and move at least 3 m. (10 feet) from fueling spot before starting the engine. Wipe off any spilled fuel before starting your saw and check for leakage.

Check for fuel leakage while fueling and during operation. If fuel leakage is found, do not start or run the engine until leak is fixed and spilled fuel has been wiped away.

### Starting (G)

Your cut-off saw is a one-person saw. Do not allow other persons to be near the saw.

Start and operate your saw without assistance.

Place the saw on firm ground or other solid surface in an open area. Maintain a good balance and secure footing.

Be absolutely sure that the cutter wheel is clear of you, all other obstructions and objects, including the ground. To start a cold engine, starting throttle (half throttle) must be used. The starting throttle will cause the engine to operate above idle rpm. The engine speed will be fast enough for the clutch to engage the drive wheel and turn the wheel which can cause an accident if the wheel catches something. Hold the saw with a firm grip. When a heavy diamond or carbide-tipped blade is used, the saw can be slightly front heavy. When the saw is placed on its support, it may tilt forward until the blade touches the ground. Before the saw is started, place it on its support to see if it tilts forward. If the saw is front heavy, it should not be placed on the ground after it has been used until the blade has come to a complete stop. During starting, when the saw is placed on the ground, the blade will turn until the starting throttle is released. **Do not allow the blade to touch the ground until it has come to a complete stop. (G, E)**

When you pull the starter grip, don't wrap the starter rope around your hand. Do not allow the grip to snap back but guide the starter rope fully back to permit the rope to rewind properly. Failure to follow this procedure may result in injury to hands or fingers and may damage the starter mechanism. Pull the starter rope out smartly a few times until the engine starts. Your instruction book gives detailed information as to how your specific model shall be started.

As soon as the engine starts, the throttle should be squeezed slightly to release the starting throttle. The engine can now assume idle speed.

### Warning (G)

**When the throttle control is released, it must move by itself to the idling position. When the engine is idling, the wheel must stop and remain stationary. If the RPM does not return to idle after the throttle is squeezed and released (release of the**

starting throttle), the cut-off saw must be adjusted. See the appropriate section of your instruction book. Do not drop start. This method is very dangerous because you may lose control of the saw. Never attempt to start the cut-off saw when the wheel is in a cut. This can result in “kick-back” and/or damage to the wheel and implies a safety hazard.

### **Guard**

The guard must be set so the rear section is close to the work piece. Grinding particles and dust are then trapped by the guard and directed away from the operator.

Under no conditions may the guard be modified from its original design except with the permission of the manufacturer in writing. Non-authorized modifications can imply considerable safety risk and cause serious injury.

**It is strictly prohibited to run the cut-off saw:**

- Without a guard;
- with a guard that is damaged;
- with a guard that has an unauthorized modification;
- with the guard not properly adjusted.

### **Cutter Wheel**

When to cutter wheel is new, you should run it at full throttle without load for 30 seconds before putting it to use. The guard must be in place. This test will reveal any hidden defects. If the wheel wobbles or “pounds” or shows any signs of cracks, it must be discarded.

### **Working Technique**

The different types of wheels have specific characteristics. The following working techniques are of a general nature. Check under the instructions for each type of wheel for their individual characteristics.

Best results are obtained if a combination of high wheel speed and high feed pressure are used. Diamond blades require less feed pressure than abrasive wheels. Too high pressure will lower the wheel speed too much. Too high or too light pressure will slow down the cutting speed. The gasoline driven cut-off saw gives best performance around 7000-8500 RPM engine speed. The wheel RPM is always lower due to the belt reduction. Always open the throttle fully before you apply the wheel to the material and regulate the RPM of the cut-off saw by increasing or decreasing the feed pressure. The abrasive cutting operation generates a great deal of localized heat which causes rapid expansion of the piece being cut. Move the wheel slowly backward and forward in the cut to get as small surface area and as high surface pressure as possible.

A small surface area reduces friction induced-heat in favor of a more rapid cutting action. That will also ensure conduction of heat away from the wheel. If possible, cool the wheel with water when cutting stone, concrete, etc. The results are less dusting, excellent wheel economy and longer wheel life.

Be sure the work piece is securely held down -- both sides of the cut if practical. The work piece should always be supported so that the cut will open when the cut is executed. Beware of “Pinching”, page 18. Start the cut gently at full throttle. Do not bump or jam the wheel to start a cut. Feed the wheel through the work as fast as possible without slowing the wheel in the cut. Don't baby the wheel through the cut. Do not catch, wedge or jam the wheel in the cut. That will increase the temperature and lower the life expectancy of the wheel. It can also cause an abrasive wheel to break which can lead to possible injury.

## **Wet Cutting**

Wet cutting is used primarily for two reasons. If the wheel is sprinkled with water, the water will keep the dust down. This is important for the operator as well as the neighborhood. Water sprinkling also cools the wheel which results in a longer life length of the wheel. Wet cutting is thus recommended in masonry materials. Wet cutting is not recommended when metal wheels are used.

The disadvantages with wet cutting, except the extra work with hoses and water tanks, are mainly:

- the operator will be exposed to water;
- problems when working in freezing temperatures;
- the mixture of concrete and water could be damaging, for example, to floors.

When the work is done and the water sprinkling has stopped, an abrasive wheel should be allowed to run at operating speed for at least 30 seconds before the wheel is stopped. That will allow all water to be thrown off. If a wheel is wet when stored, the water will gather at the lowest part, and the wheel will become out of balance. The imbalance may be so severe that the wheel breaks, you lose control of the saw, or both. In any case, this implies a safety hazard which may result in possible injuries.

**Due to the risk for electrocution, wet cutting may, under no circumstances, be used in conjunction with any electric cut-off saw.**

## **Sharpening of the Wheel**

The wheels become dull very fast and lose their cutting ability if the bonding material is not worn away at a proper speed. This could happen if a too low feed pressure is used or when cutting in heavily reinforced concrete. The steel will polish the wheel rather than grinding away the binding material. When using a dry cutting diamond blade, it is extremely important that the blade is kept sharp as the risk for too high temperatures is greater during dry cutting. If you continue to force a wheel that has lost its cutting ability, this will result in over heating, and if using a diamond blade, eventually the loss of one or more segments.

Dress (cut) on soft material such as sandstone, silica brick, haydite brick, or similar. The wheel may require additional dressing (sharpening) if hard material is still being cut.

## **Vibrating Wheels**

If the wheel is jammed into the material or too high feed pressure is used, the wheel may become out of round. This will cause the wheel to vibrate. Lower the feed pressure until the vibration has disappeared. When a lower pressure is used, the wheel has a tendency to round itself. If the vibration does not disappear, the wheel has to be discarded.

## **DO NOT**

**DO NOT use a wheel that has been dropped. The impact may result in breakage.**

**DO NOT, under any circumstances, cut with the side of the abrasive wheel. If the side is used, the reinforcing web will be cut off. Due to the high peripheral speed, large sections of the wheel can be broken off and thrown away at high speed. This is a safety hazard and can cause serious injury to the operator or any bystander.**

## **Reactive forces**

Reactive forces that may occur during any cut are **kick-back, pull-in and rotation**. Reactive forces can be dangerous. With any cut-off saw, the powerful force used for the cutting operation can be reversed and work against the operator. If the rotating wheel is suddenly stopped by contact with a workpiece, the reactive forces instantly occur.

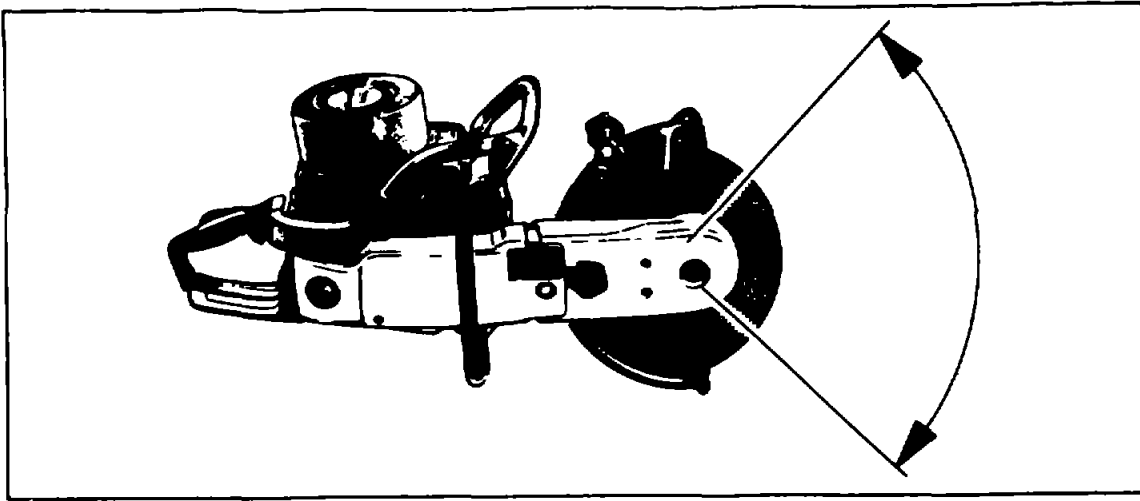

**These reactive forces may result in loss of control which may, in turn, cause injury. An understanding of the cause of these reactive forces may help you to avoid loss of control.**

### **Kick-Back**

Kick-back may occur when the outer quadrant of the wheel contacts the work piece or is pinched. The reaction of the cutting action of the wheel causes a rotational force of the cut-off saw in the direction opposite to the wheel movement. This may fling the saw in an uncontrolled arc mainly in the plane of the wheel.

Under some circumstances, the wheel can move toward the operator and may cause severe injury. The greater the force of kick-back reaction, the more difficult becomes for the operator to control the saw. Many factors influence the occurrence and force of the kick-back reaction.

- The speed of contact at which the wheel contacts the object. Kick-back forces increase with rate of impact.
- The contact angle between the wheel and the object. Kick-back is most pronounced in the outer quadrant of the wheel.
- Type of wheel used.

Kick back can occur with any wheel. However, due to its design, carbide tipped blades are more subject to kick back and they also cause a more severe injury if they touch a person.

### **To avoid kick back**

The best protection from personal injury that may result from kick back is to avoid kick-back situations.

1. Hold the cut-off saw firmly with both hands.  
Use a grip with the thumb and fingers encircling the handles as shown.
2. Maintain a good balance and secure footing.
3. Avoid cutting with the outer quadrant of the disc.
4. Don't overreach.
5. Don't cut off balance.
6. Begin and continue cutting at full throttle.
7. Use caution when reentering a previous cut.
8. Be alert for shifting of the work piece or other forces that may cause the cut to close and pinch the wheel.

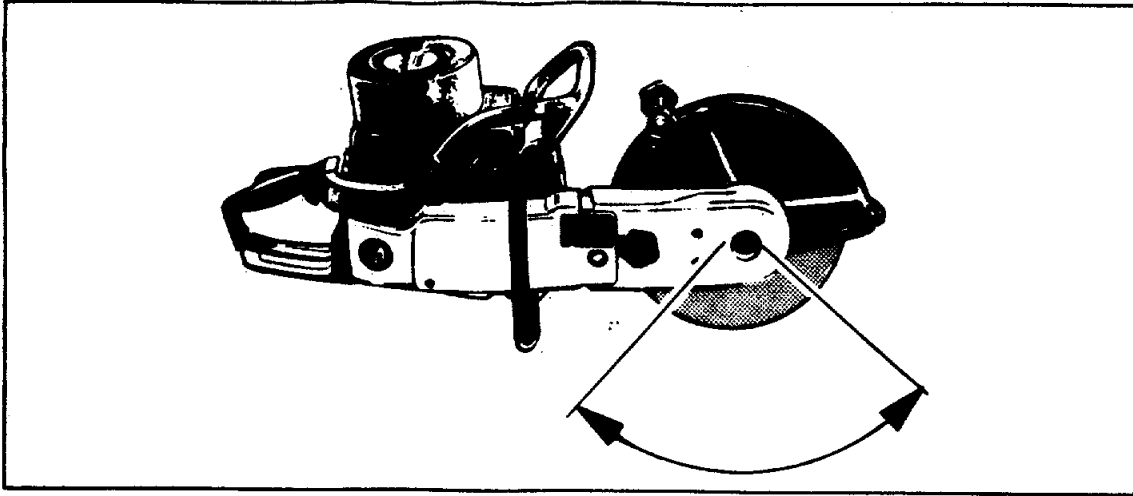

**Pull-in**

Pull-in occurs when the lower quadrant of the wheel is suddenly stopped or if the cut slowly closes. The reaction of the wheel pulls the cut-off saw forward causing the operator to lose control.

**To avoid pull-in**

Same as for avoiding kick back. The reasons for pull in are mostly too low wheel speed or a closing cut. In the latter case, the work piece is not properly supported.

See "Pinching" below.

**Pinching/Rotation**

Be alert for shifting of the work piece or other forces that may cause the cut to close or pinch the wheel. If the closing forces are strong enough, the wheel cannot work itself away from the work piece as in the case of kick back. When the wheel stops, the reactive forces will, with great force, pull the cut-off saw downwards, rotating around the center of the wheel.



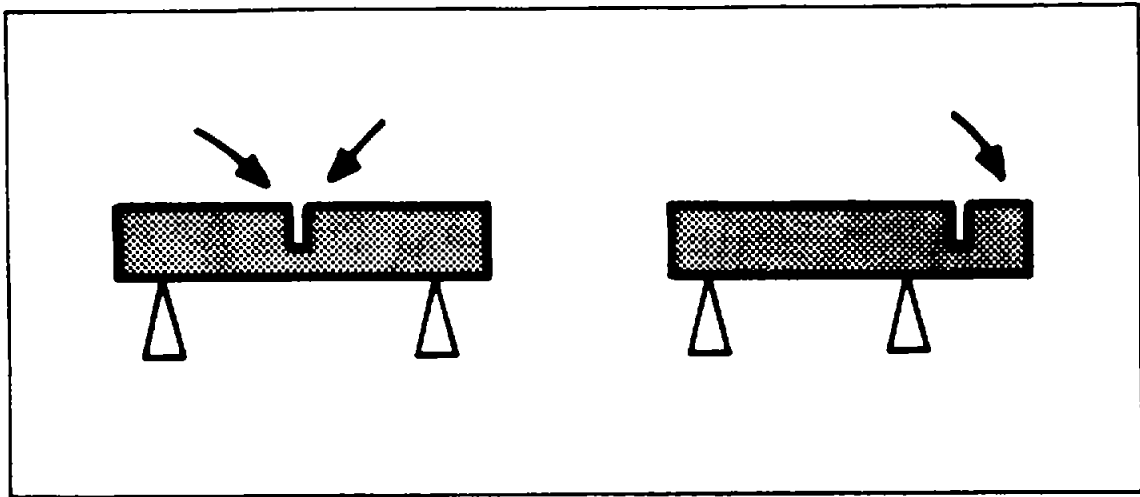

### **To avoid pinching**

The work piece should always be supported so the cut will open (not close) when the cut is executed.

### **Muffler and Exhaust Gases**

The noise from a two-stroke engine may cause impaired hearing, especially over a long period of use. Always wear hearing protectors while working with a cutoff saw. The muffler should be in good condition. A cracked or broken muffler increases the noise level which is detrimental both to the operator and the neighborhood. When the engine is running, the muffler is hot and causes burns if touched.

**The exhaust gases contain poisonous elements such as carbon monoxide. Only run the cut-off saw in well-ventilated areas. Special attention must be given to the danger of carbon monoxide poisoning if working in deep excavations and trenches. Such poisoning can be fatal.**

### **Maintenance**

Please refer to the instruction book for your model which lists necessary maintenance and service work that can be performed by the operator.

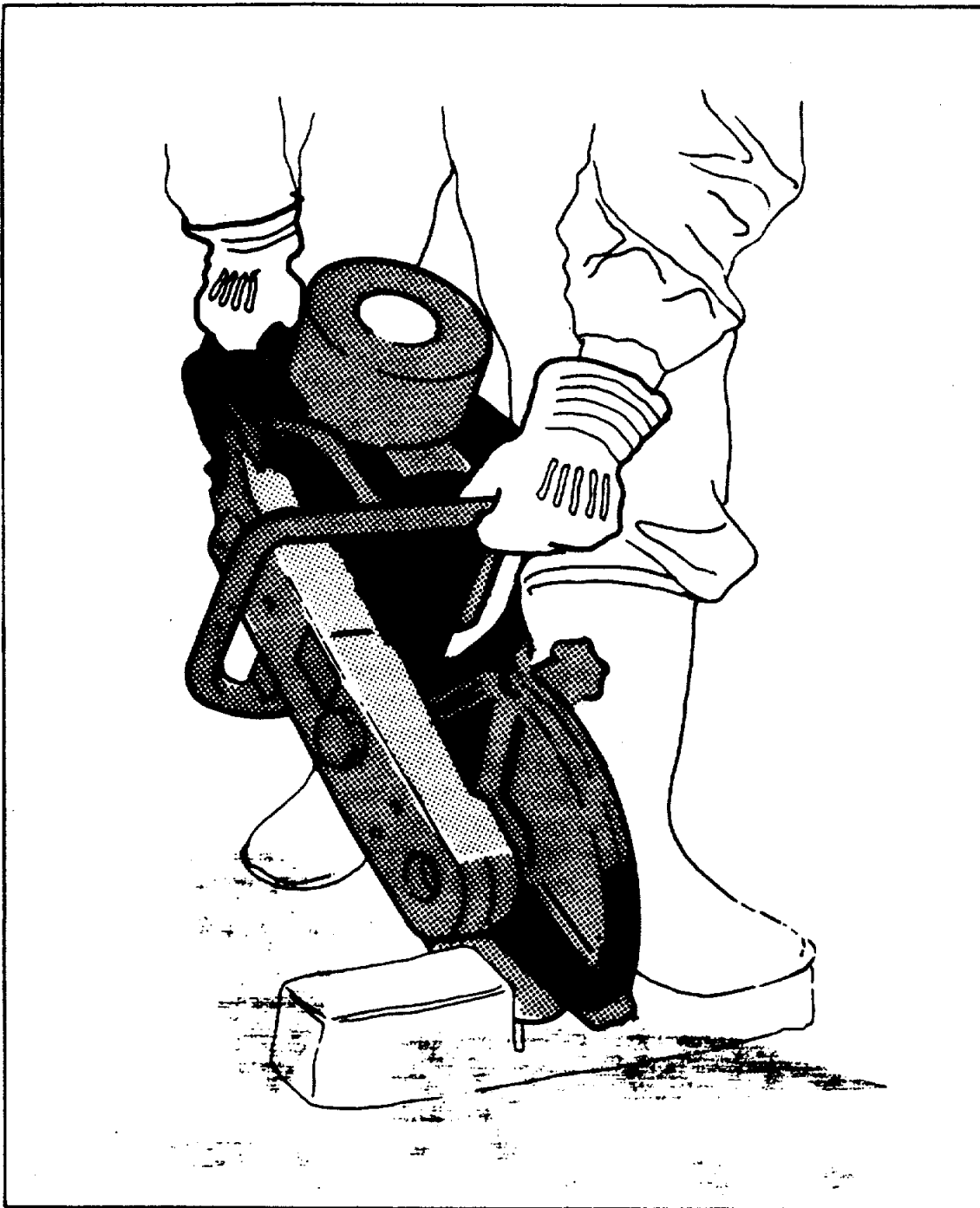

### **Safety Regulations**

Any person who is to use and/or be responsible for the maintenance of a cut-off saw must be well acquainted with current safety regulations, the way in which the machine is to be used, and serviced. Use cutter wheels which have been selected and tested for these types of cutoff saws from the viewpoints of safety, cutting capacity and life length.

1. Never use a cut-off saw unless you have been trained for this purpose. If not handled properly and with care, a cut-off saw can be a dangerous tool. Operation of a cut-off saw should be restricted to mature, properly instructed adults. Contact your local authorities and carefully follow their regulations.

2. Don't work when tired, under stress, fatigue or under the influence of medicine, drugs or alcoholic beverages.
3. Do not work alone. Make sure you can contact people in the event of an accident.
4. The following safety equipment must always be used:
  - Helmet
  - Hearing protectors
  - Protective goggles of approved type
  - Snug fitting clothing
  - Safety footwear
5. Check out the cut-off saw before it is to be used.  
Never use a saw that is damaged, faultily adjusted or not completely and securely assembled.
6. The saw must never be used without the guard.  
The guard must be adjusted so that its rear section is close to the work piece.
7. Only use cutter wheels that have been approved for hand-held portable high-speed cut-off saws. The maximum operating speed established for the wheel may never be exceeded. Inspect all wheels before mounting for possible damage in transit. Do not use a wheel that has been dropped.
8. Always allow newly mounted abrasive wheels to run at operating speed with guard in place for at east 30 seconds before you start to use them.
9. (G) Always be very careful when handling fuel. Move the cut-off saw at least 3 m. (10 feet) from the fueling spot before starting the engine.
10. Do not permit anyone to stand close to the cut-off saw when it is running or in use. Make sure spectators or animals are kept away from the working site.
11. (G) Before starting and using the machine, make sure that you have a secure foot-hold. When the machine starts, the cutter wheel begins to rotate. This makes it important to stand firmly and ensure that the wheel can rotate freely. Do not start cutting until you have a clear work area and secure footing.
12. Always hold the cut-off saw with both hands while the engine is running. Use a firm grip with thumbs and fingers encircling the handles. Keep all parts of your body away from the cutting-off wheel when the engine is running.
13. When the throttle control or switch is moved to the idling position, the cutter wheel must stop and remain stationary.
14. Keep the handles dry, clean and free from oil or fuel.
15. Do not cock jam or wedge the wheel in the cut.
16. Do not grind on the side of a cutting-off wheel.
17. Do not cause sparks in the vicinity of anything that is flammable.
18. After wet cutting, an abrasive wheel should be run at operating speed for 30 seconds after water sprinkling has ceased to allow all water to be thrown off.
19. (G) Exhaust fumes are poisonous. Only use the cut-off saw in well-ventilated places. Failure to use the cut-off saw in well-ventilated areas can lead to carbon monoxide poisoning.
20. The engine must be switched off when the cut-off saw is carried. Make sure the muffler faces away from your body.
21. The cutter wheel must be removed from the cut-off saw when it is transported or stored.
22. All service with the exception of maintenance service described in the instruction book must be carried out by an authorized service workshop. Under no conditions may a cut-off saw be modified from its original deign without the written permission from Electrolux Motor AB. Non-authorized modifications can lead to serious injury or death to yourself or other people.

4177

**BLACKHAWK®**



**Porto-Power®**

**Operating Instructions**

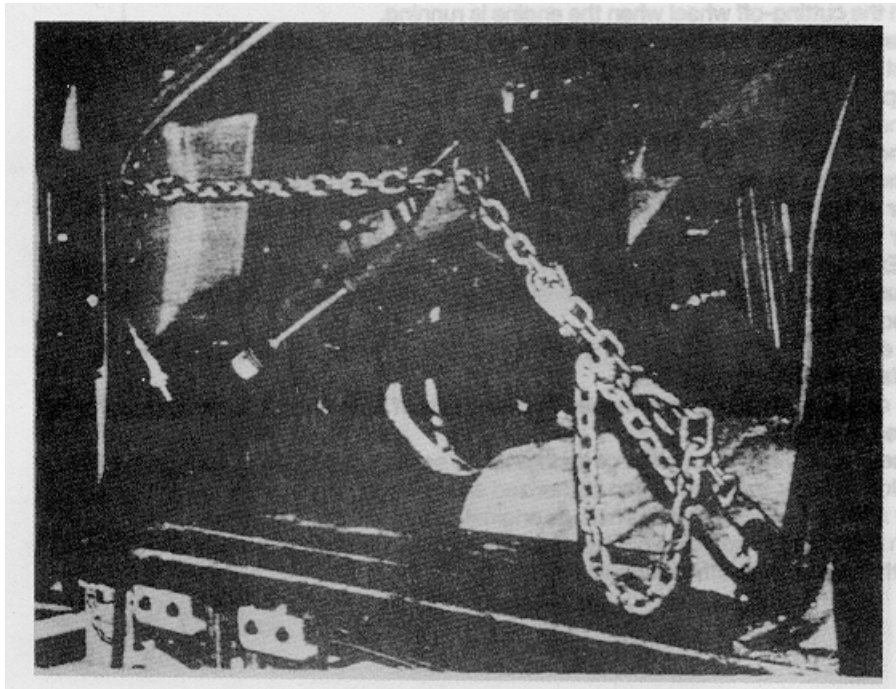

**Body Repair Equipment**

**PORTO-POWER® SOLVES 1,001  
FORCE RELATED PROBLEMS**

- Auto Body/Frame Repair
- Heavy Duty Truck Repair & Maintenance
- Construction - Road Equipment - Building, Etc.
- Farm - Fleet Equipment Maintenance
- Rescue

And the list could go on and on.

Your Porto-Power is the world's finest remote controlled hydraulic jack. Porto-Power, with its wide range of rams and attachments, provides countless combinations for pushing-pulling-spreading clamping and pressing. It has universal application in all of the above mentioned fields.

Porto-Power has been designed and engineered with unusual thought and consideration to help you solve difficult problems and make your job easier. The wide variety of field-tested attachments can be assembled into many combinations providing you with 1,001 valuable aids to make your work more efficient.

Porto-Power - Blackhawk  
are registered trade marks

## TROUBLE-SHOOT CHART SOLUTIONS

### 1. Spongy effect

Air trapped in the hydraulic system easily compresses under pressure and causes sponginess.

To bleed system: Place pump at a higher elevation than the hose and ram. The objective is to "float" the air bubbles up hill and back to the reservoir where they belong. See figure 1.

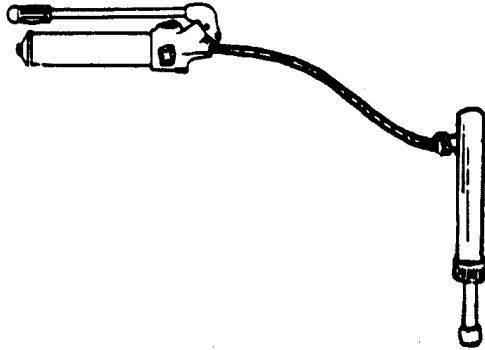

Figure 1.

Close valve and extend ram as far as possible. Open valve fully allowing oil and air to return to reservoir. Repeat this procedure until ram starts to extend on the first stroke of the handle. Usually two or three times will do the trick.

### 2. Ram won't extend all the way

Usually just low on hydraulic fluid. **FILL MARK ON DIP-STICK. DON'T OVERFILL.** Ram should be fully retracted to check oil level. This hydraulic unit needs the prescribed amount of air chambered in the reservoir, as it works on a partial vacuum to avoid venting to the outside.

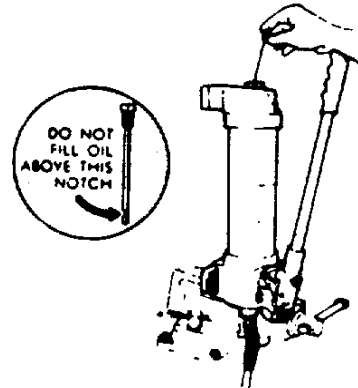

Figure 2.

### 3. Ram won't retract

Usually just too much oil and/or air in the system. Bleed system and fill to proper level. If that doesn't correct the problem, inspect closely for a bent plunger. If neither of these is the cause, the quick-coupler is probably damaged. Replace it.

## TROUBLE-SHOOT CHART

PROBLEM	PROBABLE CAUSE									
	RESERVOIR LOW ON HYDRAULIC FLUID	RESERVOIR OVER FULL	AIR IN SYSTEM	BENT PLUNGER	RELEASE VALVE NOT FULLY CLOSED	DIRT IN RELEASE VALVE	DIRT IN CHECK VALVE	LOOSE DIRT OR AIR BUBBLE IN VALVE SYSTEM	DAMAGED QUICK-COUPLER	
SPONGY EFFECT			X							
RAM WON'T EXTEND ALL THE WAY	X	X								
RAM WON'T RETRACT		X		X						X
RAM LEAKS DOWN UNDER PRESSURE					X	X				
HANDLE KICK-BACK							X			
WORKS PROPERLY ONE TIME BUT NOT THE NEXT								X		

4. Ram leaks down under pressure Make sure release valve is fully closed. If it still leaks down, there is probably dirt in the return check ball valve. Flush the system with mineral spirits or kerosene. If the problem still exists, valve is damaged and unit should go to a Blackhawk authorized repair facility.
5. Handle kick-back  
Dirt in check valve - flush system.  
Damaged check valve - should go to Blackhawk authorized repair facility.
6. Works properly one time, but not the next Loose dirt or air bubble In valve system. Flush and refill system.

**CAUTION:**  
**DO NOT USE: BRAKE, TRANSMISSION OR ANY FLUID OTHER THAN A GOOD HYDRAULIC OIL. 67070 BLACKHAWK (LX21) OR EQUIVALENT. FLUIDS OTHER THAN HYDRAULIC OIL MAY DAMAGE CUPS AND PACKINGS, CORRODE METAL PARTS AND VOID YOUR WARRANTY. FOR AIR OPERATED HYDRAULIC PUMPS REFER TO INSTRUCTION MANUAL FOR THAT SPECIFIC PRODUCT.**

**FUNCTION:**

Porto-Power equipment is designed to perform many functions The pump, ram and attachments may be used to:

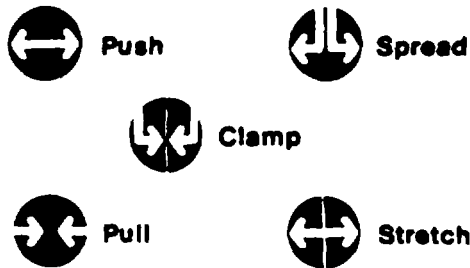

Porto-Power is available with either threaded/lock-on or SS" slip-on tubing and attachments. Threaded/ lock-on tubing and attachments can be threaded together or "lock-on" connectors can be used. "SS" slip-on tubing and attachments are not threaded and just push together for fast, easy set up.

Adaptors are available to connect one to the other.

**CAUTION:** When using threaded extensions and attachments, always thread all the way in. The se offset attachments reduces the capacity of this equipment by one-half.

Extreme care should be taken when using extension tubing and/or offset attachments to prevent damage to these Items due to overloading.

**⚠ WARNING ⚠**

DO NOT OVERLOAD RAM. OVERLOADING CAN CAUSE CRACKED CYLINDERS, BLOWN CAPS, BENT PLUNGERS AND RUPTURED HOSES. DO NOT OVER- EXTEND THE RAM. THIS MAY PUSH THE PLUNGER OUT OF THE TOP OF THE RAM WITH !VIOLENT RESULTS. WHEN USING A CHAIN DO, NOT STAND IN LINE WITH THE CHAIN AT ANY TIME. DO NOT CROSS TWIST, KINK, KNOT OR SHORTEN ANY CHAIN WITH A PIN. DO NOT ALLOW RUNNING LOADS TO PASS OVER CHAINS. DO NOT USE CHAINS OVER SHARP CORNERS WITHOUT PROTECTIVE PADDING. DO NOT FORM A LOOP BY PUTTING THE POINT OF A HOOK INTO A LINK. DO NOT USE HEAT NEAR OR ON A CHAIN OR ANY ATTACHMENT. DO NOT USE A CHAIN WHOSE LINKS ARE TWISTED OR BENT, HAVE, NICKS OR GOUGES, SHOWS EXCESSIVE WEAR STRETCH OR SPREAD IN THE LINKS. ANY SUCH CHAIN SHOULD BE REPLACED IMMEDIATELY. FAILURE TO HEED THESE WARNINGS MAY RESULT IN DAMAGE TO THE EQUIPMENT AND/OR FAILURE RESULTING IN PERSONAL INJURY AND/OR PROPERTY DAMAGE.

**TO USE:**

Select the best ram suited for your application. Connect it to the pump and hose by placing the male end of the coupler firmly into the ram half. Tighten threaded collar coupler down completely by hand. (Pliers or vise-grips will damage the seat)

Thread or push on the desired attachments to the ram.

To extend the ram close the release valve, located near the hose end of the pump, by turning clockwise until fingertight. It is not necessary to overtighten this valve as this will cause wear or breakage.

To operate the pump hold in the horizontal or vertical (hose end down) position and pump the handle.

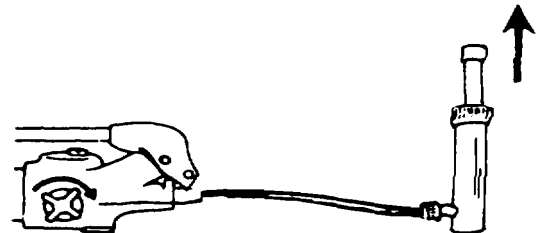

To release the ram and load turn the release knot slowly, counter-clock-wise.

## TO PROTECT THIS EQUIPMENT:

Guard ram threads with protector ring whenever possible. Protect ram plunger end or threads by using serrated saddle or other pushing attachments.

Guard against the entrance of dirt and foreign matter into the system as this may cause pump failure when coupler halves are disconnected always screw on the dust caps.

**IMPORTANT:** When applying off-center loads use extreme caution, and pump carefully. Off-center loads produce strain on the ram plunger, attachments, and extension tubes, which may result in equipment failure. Loads will be off-center when using such attachments as: Notched Pull Toe, Edge Clamp-Pusher-Head, Adjustable Body Spoon and Lift Toe. (See figure 3)

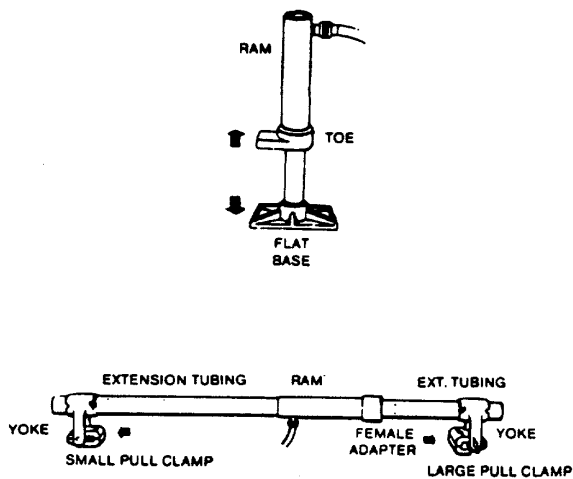

Figure 3.

## OFF-CENTER LOAD REDUCES CAPACITY

### **WARNING**

HIGH PRESSURE HYDRAULIC OIL CAN CAUSE PERSONAL INJURY. DO NOT HOLD HOSE OR FITTINGS IN YOUR HAND WHILE UNDER PRESSURE.

DO NOT DROP HEAVY OBJECTS ON HOSE. A sharp impact can damage wire braid of hose leading to possible failure or personal injury. Avoid sharp kinks and bends in hose. Periodically, inspect hoses for kinks, cuts and bulges. Remove hose from service immediately if the foregoing are observed. Do not carry the pump by the hose.

Always position set-up so that the hose and Speed-D-Coupler have clearance when the ram is extended.

Keep your equipment away from excessive heat and flame such as welding or cutting torches. Such damage may weaken or damage the equipment, especially hoses and flex heads, and could lead to failure or personal injury.

Do not adjust spring retaining screw located in the cylinder wall near the bottom, of the 20 and 50 ton rams. This screw anchors the plunger return spring and is not adjustable.

## MAINTENANCE:

As with any fine tool, care must be taken to keep equipment clean. Periodically clean and lubricate all moving parts. Always store equipment in a clean dry area to prevent corrosion. Repair or replace damaged, marred or bent extensions and threads before its next use. One damaged thread and one good thread equals two damaged threads.

## INSPECTION:

Visual inspection should be made before each use of the equipment, checking for leaking hydraulic fluid, damaged, loose, or missing parts. All equipment must be inspected by a Blackhawk authorized repair facility immediately if accidentally subjected to an abnormal load or shock. Any equipment which appears to be damaged in any way, is found to be badly worn, or operates abnormally **MUST BE REMOVED FROM SERVICE** until necessary repairs are made by a Blackhawk authorized repair facility. It is recommended that an inspection of the equipment be made by a Blackhawk authorized repair facility once a year, and that any defective parts, decals or warning labels be replaced with manufacturer's specified parts. A list of authorized repair facilities is available from Blackhawk.

## OWNER AND/OR USER RESPONSIBILITY:

Owner and/or user must study and keep these instructions for future use.

**OPERATION:** The owner and/or user must have an understanding of these operating instructions and warnings before using this equipment. Warning information is very important and should be fully understood. If the operator speaks or reads a language other than English, these instructions and warnings must be read to and discussed with the operator in the operator's native language. The purchaser/owner must make sure that the operator understands its contents.



BASIC SET-UPS USING PORTO-POWER RAMS AND ATTACHMENTS. THE PUSH, SPREAD, CLAMP, PULL, AND STRETCH SYMBOLS SHOWN BELOW AND ON THE FOLLOWING PAGES TELL YOU HOW EACH SET CAN WORK FOR YOU. OFFSET LOADS REDUCE CAPACITY BY ONE HALF.

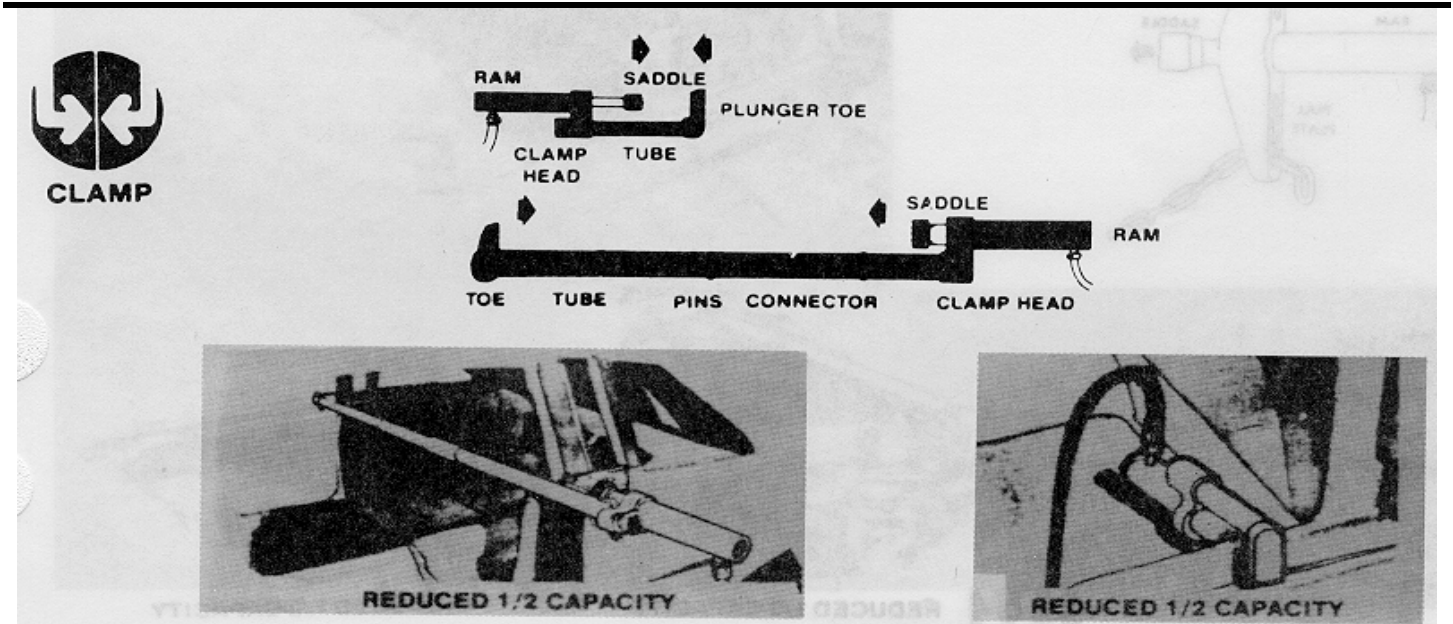
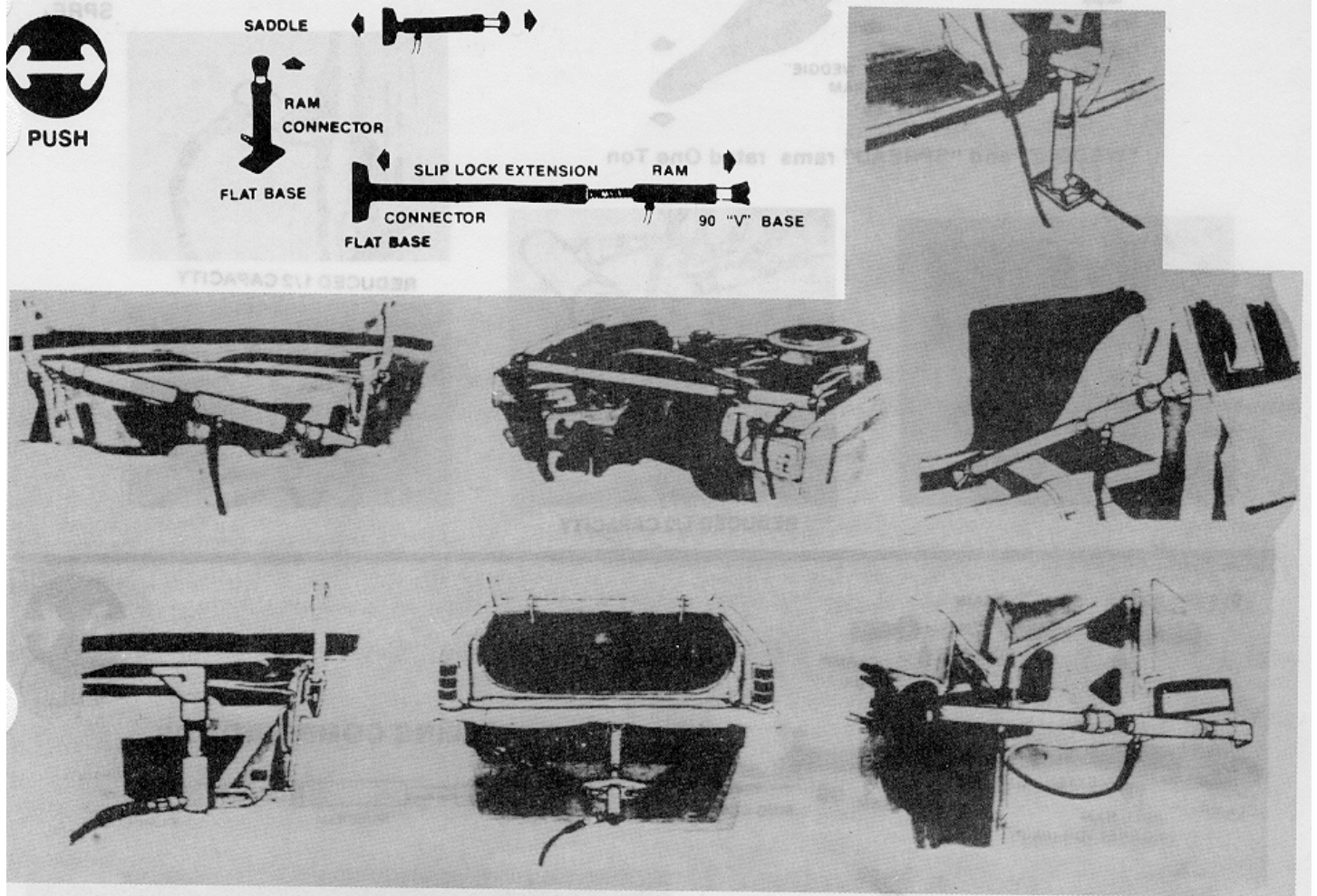

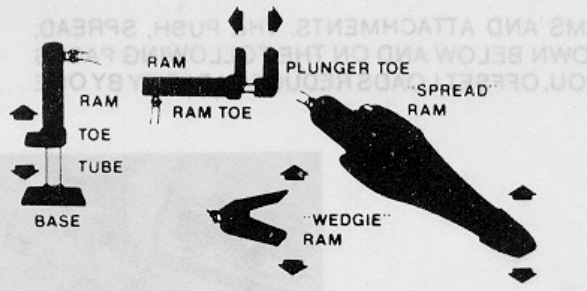

"WEDGIE" and "SPREAD" rams rated One Ton



SPREAD

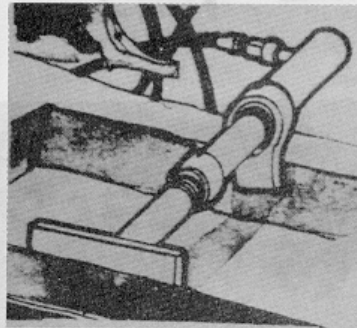
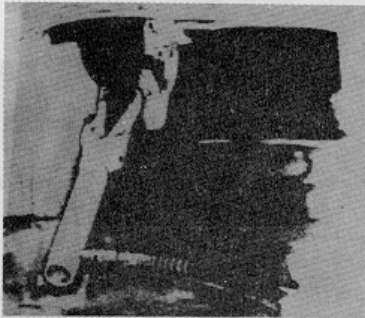

REDUCED 1/2 CAPACITY

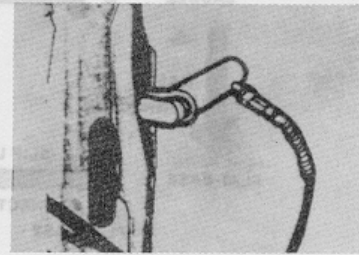

REDUCED 1/2 CAPACITY

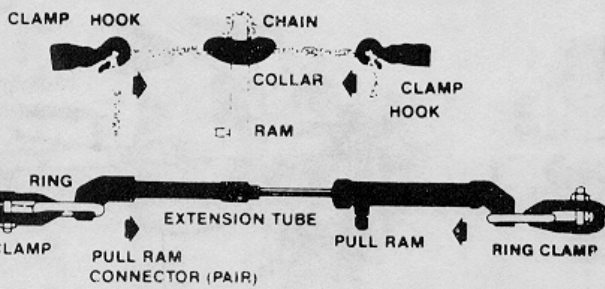
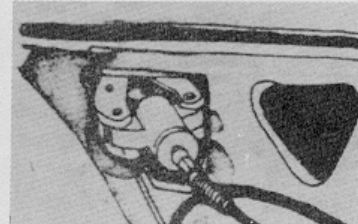

PULLING COMBINATIONS

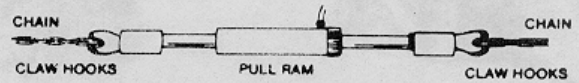

PULL

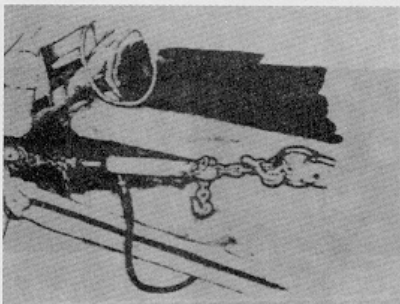
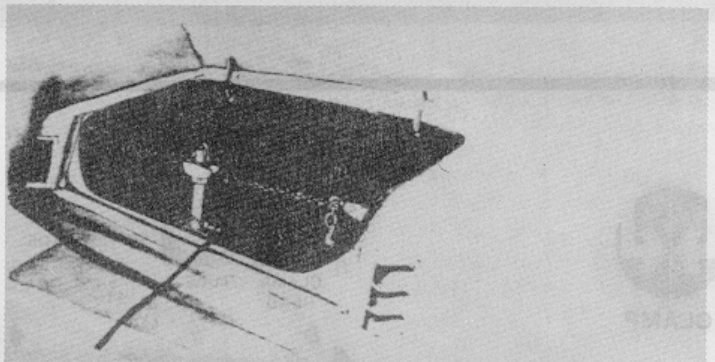
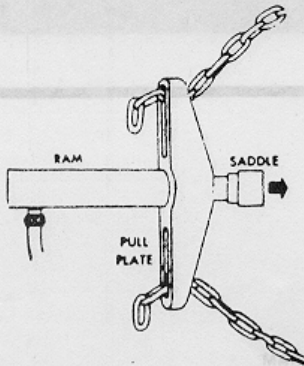

REDUCED 1/2 CAPACITY

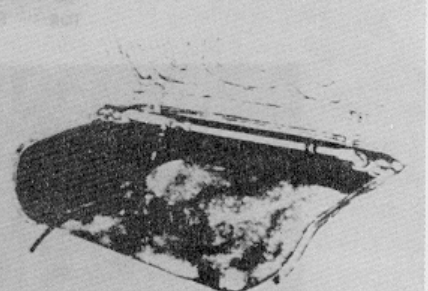
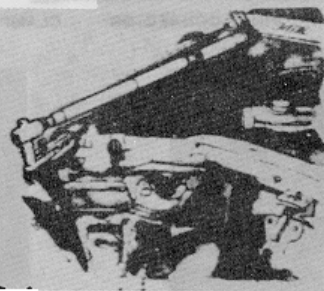

REDUCED 1/2 CAPACITY



S .CH

PIN

YOKE

SMALL

PULL CLAMP

EXTENSION TUBE

EXTENSION TUBE



LARGE PULL CLAMP

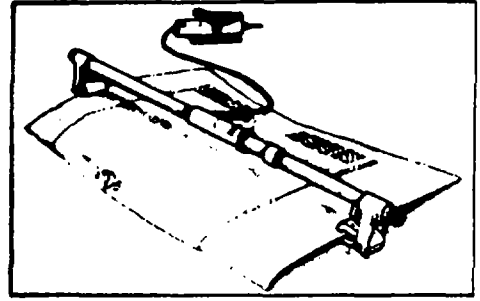

REDUCED 1/2 CAPACITY

### WARRANTY

COMMERCIAL WARRANTY: This equipment is warranted by Applied Power Inc. to the original commercial user- owner against defective materials or workmanship for a period of 90 days from the date of delivery. Hand jack models 67225, 67226, 67227, 67228, 67229, 67230, 67237, 87239, 67240, 87242, 67245, 67246 and all Porto- Power- equipment and accessories are warranted for a period on one (1) year from date of delivery. During the warranty period, equipment found to be defective will be repaired or replaced (at the warrantor's option) without charge. The equipment must be returned, transportation charges prepaid, with proof of delivery date to an Authorized Service Center. The repaired or replaced equipment will be returned with transportation charges prepaid by the Service Center.

This warranty does not cover defects in the equipment caused by ordinary wear and tear, abuse, misuse, overloading, accident (including shipping damage), improper maintenance, alteration, use of improper fluids, or any other cause not the result of defective materials or workmanship.

REPAIR OR REPLACEMENT IS THE EXCLUSIVE REMEDY FOR DEFECTIVE EQUIPMENT UNDER THIS WARRANTY. THIS WARRANTY IS EXPRESSLY IN LIEU OF ALL OTHER WARRANTIES, INCLUDING ANY IMPLIED WARRANTY OF MERCHANTABILITY OR ANY IMPLIED WARRANTY OF FITNESS FOR A PARTICULAR PURPOSE ON THIS EQUIPMENT. APPLIED POWER INC. SHALL NOT BE LIABLE FOR ANY CONSEQUENTIAL OR INCIDENTAL DAMAGES FOR BREACH OF ANY EXPRESS OR IMPLIED WARRANTY ON THIS EQUIPMENT.

Service parts, warranty, and regular repair service for products are available through a nationwide system of Authorized Service Centers which are carefully selected by the Automotive Division. Your distributor or jobber can provide you with a list of Service Centers in your area.

For additional PRODUCT AND SERVICE Information Contact:

Applied Power Inc.  
Automotive Division  
P.O. Box 27207  
11 333 W. National Ave.  
Milwaukee, WI 53227

1-800-558-4558 (Not valid In Wisconsin)

PRODUCT REPAIR: Products for repair should be forwarded to the nearest Service Center. PRODUCTS FOR REPAIR SHOULD NOT BE RETURNED TO THE FACTORY.

Applied Power Inc.  
Automotive Division  
PO 80x 27207





**SIGNAL DIVISION**  
Federal Signal Corporation

**Model PA300\***

**ELECTRONIC SIREN**



**INSTALLATION AND SERVICE INSTRUCTIONS**

## SECTION I GENERAL DESCRIPTION

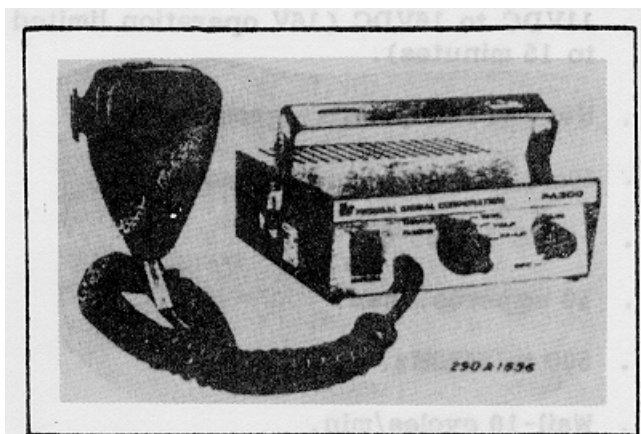

Figure 1-1. Mod PA300 Electronic Siren.

The Federal Model PA300 (figure 1-1) is a precision built, efficient and economical, full-featured electronic siren of advanced design. It provides wail, yelp and hi-lo siren tones, as well as the Tap II feature, public address (PA), radio rebroadcast and an air horn sound.

The siren may be installed in positive or negative ground vehicles with 12-volt electrical systems. It is protected against failure modes (including reversed polarity) by a fuse that is replaceable without tools. No components protrude from the bottom of the siren to interfere with mounting arrangements.

A noise-cancelling microphone is wired-in to prevent loss or theft. It provides high quality voice reproduction without feedback "squeal". The microphone push-to-talk switch overrides any siren signal for instant PA use. PA

and radio volume are adjustable by means of a front panel GAIN control. Radio interconnect wires are built in. No additional cables are required.

The Model PA300's 100-watt output is designed to drive a single high power speaker.

The Tap II feature allows the driver to change the siren sound from wail to yelp (or vice-versa) via the vehicle's horn ring. Tap II provides especially effective traffic clearing capability. In addition to Tap II, additional alternate sounds can be activated in two other selector switch positions by depressing and holding the horn ring for as long as the alternate sound is desired. The charts in Section IV of this manual illustrate the operation of these features more fully.

Other special features of the Model PA300 include:

- o High degree of reliability is achieved through the use of integrated circuits and silicon output transistors.
- o Control panel is illuminated with non-glare lighting.
- o Newly designed printed circuit board provides improved performance and durability under a wide range of environmental conditions.

**SECTION II  
SPECIFICATIONS**

Input Voltage .....	11VDC to 16VDC (16V operation limited to 15 minutes).
Polarity.....	Negative or positive ground.
Standby Current .....	50mA max. (not incl. panel light).
Operating Temperature Range .....	-300C to +650C.
Operating Current (14VDC-Wail mode) .....	10 amperes, max.
Frequency Range.....	500 to 1500Hz.
Cycle Rate.....	Wail-10 cycles/min. Yelp-180 cycles/min. Hi-Lo-60 cycles/min.
Voltage Output (approx.) .....	64V peak-to-peak.
Dimensions (HWD) .....	2-1/2" (6.35cm) x 6-1/2" (16.51cm) x 8-1/2" (21.59cm).
Net Weight (incl. microphone).....	4-1/2 lbs. (2.04kg).
Shipping Weight .....	6-1/2 lbs. (2.94kg).

**NOTE**

The following parameters were obtained with the radio input potentiometer and GAIN control set at maximum.

Audio Frequency Range.....	300 to 10,000Hz
Harmonic Audio Distortion (300-3,000Hz).....	10% max. all power levels from 1/2 to 50 watts (frequency response $\pm 3$ dB).
Input Impedance (Radio).....	2000 ohms
Input voltage required to obtain 20VRMS across speaker load (Radio) .....	0.55VRMS

## **SECTION III INSTALLATION**

### **3-1. UNPACKING.**

After unpacking the Model PA300, examine it for damage that may have occurred in transit. If the equipment has been damaged, file a claim immediately with the carrier stating the extent of the damage. Carefully check all envelopes, shipping labels and tags before removing or destroying them.

### **3-2. MOUNTING BRACKET.**

The PA300 comes equipped with a swinging bracket which enables it to be mounted in a variety of positions. Positioning the bracket above the unit allows mounting to the underside of the dash. Positioning the bracket below the unit will permit mounting on any horizontal surface or, by the use of Federal's TU-70 Tunnel Mount on the vehicle's transmission hump.

The unit should be mounted in a position that is both comfortable and convenient to the operator. Keep visibility and accessibility of controls in mind. To install the unit under the dash, determine the mounting location and proceed as follows (see figure 3-1).

#### **CAUTION.**

The unit must be installed in an adequately ventilated area. Never install near heater ducts.

A. Use one of the mounting brackets as a template and scribe two drill positioning marks at the selected mounting location under the dash.

B. Drill two 1-inch diameter holes at the position marks.

C. Secure the mounting bracket to the dash with (2 each) ¼-20 x ¾ hex head screws, ¼ split lockwashers and ¼-20 hex nuts as shown in figure 3-1.

D. Secure the PA300 unit to the mounting bracket with 1-20 x 3/8 hex head screws and 1 split lockwashers.

E. Tilt the unit to the desired position. Tighten the 1-20 x 3/8 hex head screws.

NOTE: When installing the PA300 on the transmission hump, a Federal Model TU-70 Tunnel Mount is recommended. The TU-70 Tunnel Mount is drilled and tapped for the PA300 mounting bracket.

Follow the installation instructions packed with each unit.

### **3-3. POWER CABLE INSTALLATION.**

The power cable included in the carton is equipped with a twelve-prong plug (P5) that mates with the connector (J5) on the rear of the electronic siren (see figure 3-2). The various wires on the connector must be connected as described below.

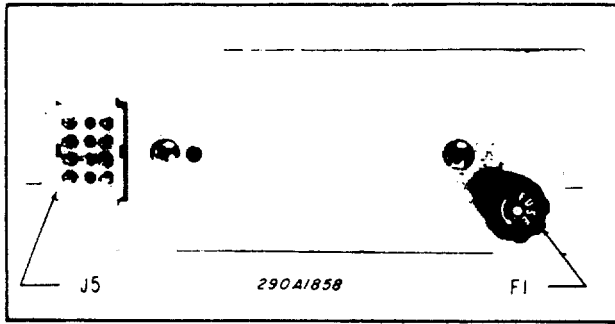

Figure 3-2. Rear View of PA300.

**WARNING**

Do NOT connect the siren to the vehicle battery until ALL other electrical connections have been completed.

A. Speaker.

The unit is designed to operate with one 11-ohm, high power speaker.

A speaker is not included as part of the electronic siren. FEDERAL speakers are weatherproof and may be installed in any convenient location; on the roof, fender, behind the grille, etc. Any special mounting instructions applicable to the type of speaker you have selected will be found in the speaker carton.

Connect the speaker leads (18 gauge wire) to the blue power cable leads of P5 (pins 1 and 3) as shown in figure 3-3.

B. Radio.

To allow incoming radio messages to be rebroadcast over the outside speaker, connect the two brown zip cord leads (P5, pins 9 and 12) across the two-way radio's speaker.

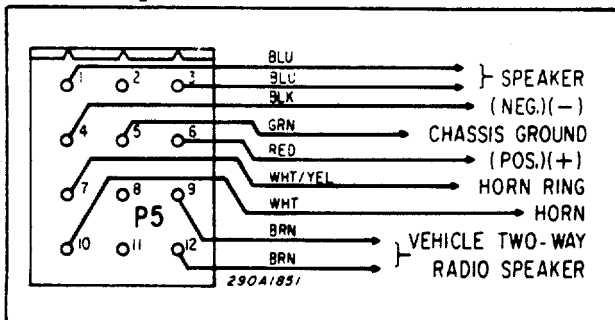

Figure 3-3. Control Cable Wiring Diagram.

C. Horn Ring.

In order to utilize the Tap II and Press-and-Hold features of the siren, the following procedure must be performed.

1. Locate the wire that connects the vehicle horn ring switch to the horn or horn relay. Cut this wire.
2. See figure 3-4. Splice the white/yellow control cable wire (P5, pin 7) to the horn ring side of the wire that was cut in step 1. Insulate the splice with the wire nuts (supplied).

**CAUTION**

The horn ring transfer circuit of the siren is capable of switching a maximum of 2-amperes. Some vehicles do not have a horn relay and, consequently, will draw more than 2-amperes when the vehicle horn is activated. Consult your vehicle service manual or a qualified mechanic to determine the current required to activate the horn. If it is less than 2-amperes, perform the procedure in step 3. If it is greater than 2-amperes, perform steps 4 through 10.

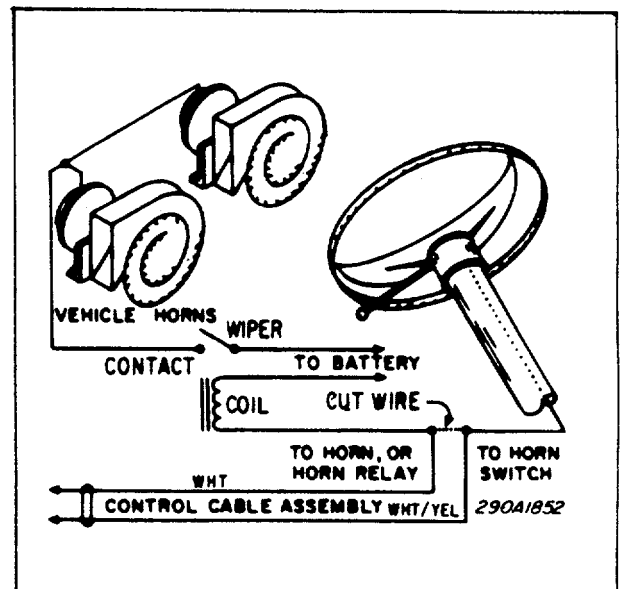

Figure 3-4. Horn Ring Connections.



3. Splice the white control cable wire (P5, pin 10) to the horn side of the cut wire. Insulate the splice with a wire nut.

4. Obtain a SPST relay of sufficient contact current capacity to activate the vehicle horn. Refer to figure 3-4 while performing the following steps.

5. Mount the relay in a suitable location.

6. Connect the horn side of the wire cut in step 1 to the relay contact terminal.

7. Determine the "sense" of the vehicle's horn ring activation circuit, i.e., does the horn circuit require a switched positive voltage or switched ground for activation.

8. Connect the relay wiper terminal to the positive or negative potential determined in step 7.

9. Connect the white control cable wire to one end of the relay coil.

10. Connect the other end of the relay coil to the opposite potential of that connected to the wiper in step 8.

#### D. Connection to Power Source.

The PA300 can operate from any 12-volt positive or negative ground vehicle electrical system. Therefore, before making any electrical connections, determine the polarity of the vehicle electrical system ground.

Power for the siren can be obtained from the vehicle's power distribution center (Federal's Model PDC70 is recommended) or directly from the vehicle battery. If power is going to be obtained directly from the vehicle battery, drill a hole in the vehicle firewall for the power lead to enter the engine compartment. Place a grommet or similar device in the hole to protect the wire against damage from rough edges.

### **CAUTION**

When drilling holes on ANY part of the vehicle, ensure that both sides of the surface are clear of parts that could be damaged; such as brake lines, fuel lines, electrical wiring or other vital parts.

If your vehicle has a negative ground electrical system, perform the procedure in paragraph 1. Perform the procedure in paragraph 2, if the vehicle has a positive ground system.

#### 1. Negative Ground.

a. Connect the green (PS, pin 5) and black (PS, pin 4) control cable leads to the vehicle chassis as close as practical to the siren. Scrape paint away from the selected bolt hole to ensure a good electrical connection to the chassis.

b. Route the red control cable lead (P5, pin 6), through the previously drilled hole, into the engine compartment. Route the wire through existing clamps and holders toward the battery.

c. To protect the wire when connected to the battery terminal, use an in-line fuseholder and 15-ampere fuse (not supplied). The fuseholder should be installed as close as practical to the battery. If necessary, additional #14 gauge or heavier wire can be spliced to the red lead.

d. Connect the in-line fuseholder lead to the positive (+) battery terminal.

#### 2. Positive Ground.

a. Connect the green (PS, pin 5) and red (PS, pin 6) control cable leads to the vehicle chassis as close as practical to the siren. Scrape paint away from the selected bolt hole to ensure a good electrical connection to the chassis.

b. Route the black control cable lead (PS, pin 4), through the previously drilled hole, into the engine compartment. Route the wire through existing clamps and holders toward the battery.

c. To protect the wire when connected to the battery terminal, use an in-line fuseholder and 15-ampere fuse (not supplied). The fuseholder should be installed as close as practical to the battery. If necessary, additional #14 gauge or heavier wire can be spliced to the red lead.

d. Connect the in-line fuseholder lead to the negative (hot) side of the battery terminal.

**3-4. AIR HORN PRESS AND HOLD MODIFICATION.**

The unit comes from the factory set so that the peak-and-hold sound will be heard when the Selector switch is set to MANUAL and the vehicle horn ring is activated. To change the sound to air horn, merely move jumpers JU1 and JU2 from the "PEAK" position on the P.C. board to the "AIR" position (see figure 3-5).

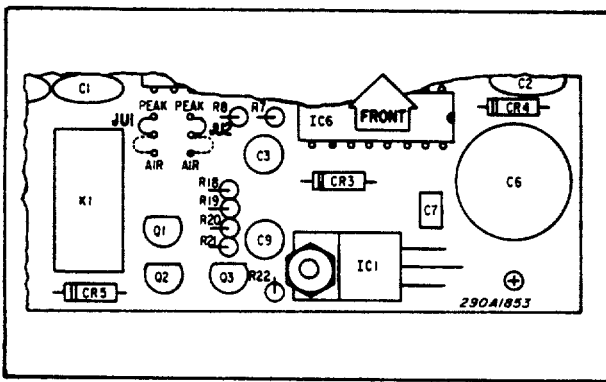

Figure 3-5. Press and Hold Modification.

**3-5. RELATIVE PA LOUDNESS ADJUSTMENT.**

After the PA300 is completely installed in the vehicle, set the Selector switch to MANUAL. Depress the microphone push to-talk switch, speak in a normal voice, and adjust the GAIN control for the desired sound level outside the vehicle. Turn on the vehicle's two-way radio and adjust the volume to a comfortable listening level inside the vehicle. Then set the Selector switch to radio. Stand outside of the vehicle and note the radio rebroadcast loudness. If the sound volume is too loud or too soft, adjust R11 through the hole at the bottom of the siren (see figure 3-6) to the desired sound level.

After the adjustment is completed, the loudness of the radio rebroadcast and public address may be varied with the front panel GAIN control.

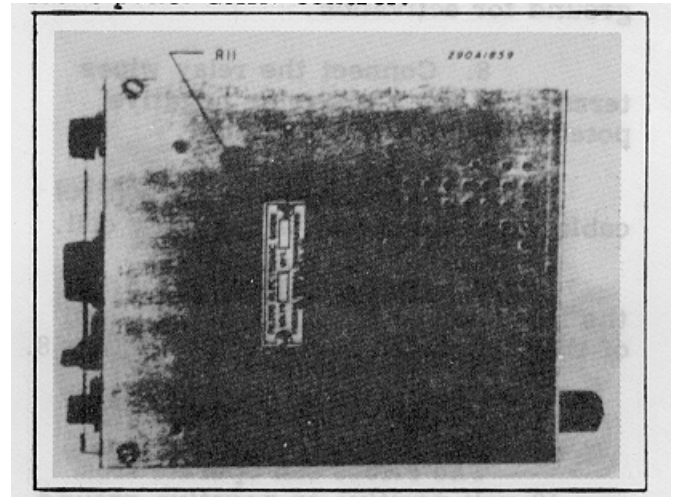

Figure 3-6. Relative PA Loudness Adjustment

## SECTION IV OPERATION

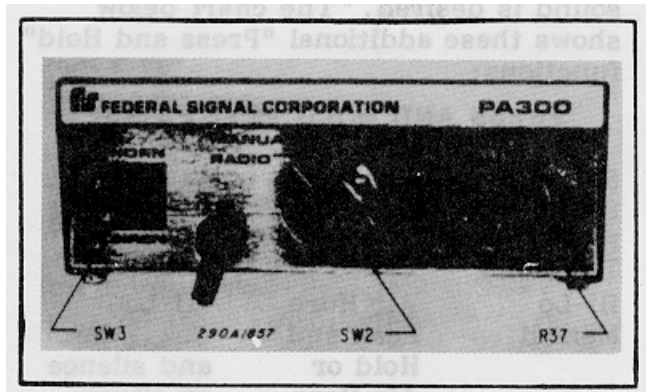

Figure 4-1. Model PA300 Front View.

### 4-1. GENERAL.

All controls utilized during normal operation of the Model PA300 are located on the front panel (see figure 4-1).

The wired-in noise cancelling micro- phone provides high quality voice reproduction in the public address mode. The microphone push-to-talk switch will override all siren functions, except radio rebroadcast, for instant PA use.

### 4-2. GAIN CONTROL.

The GAIN control is used to turn the siren on and off. Also, it is used to control the volume when the siren is used for public address or radio amplification. Clockwise rotation of the knob increases voice volume in the public address or radio amplification mode. The GAIN control does not control the volume of the siren signals.

The maximum clockwise setting of the control will be determined, in most cases, by the point at which feedback or "squeal" occurs. This will depend upon the microphone gain, open windows, speaker placement, proximity of reflecting surfaces (building or other vehicles), etc. Adjust the GAIN control to a position just below the point at which feedback occurs or as desired.

### 4-3. SELECTOR SWITCH.

The Selector switch is a five-position rotary switch used to select the mode of operation. The following are positions on the Selector switch.

#### A. RADIO.

In this position, incoming radio messages are amplified by the siren and rebroadcast over the outside speaker.

#### B. MANUAL.

In this position, it is possible to operate the siren by activating the HORN/SIREN switch. The siren can also be activated by means of an auxiliary switch, such as the horn ring button (refer to paragraph 4-6).

#### C. WAIL.

In this position, the siren produces a continuous "wailing" sound, up and down in frequency.

#### D. YELP.

In this position, a continuous rapid "warbled" tone is generated.

#### E. HI-LO.

In this position, a two-tone sound will be heard. This distinctive tone may be reserved for any special indication or situation.

### 4-4. HORN/SIREN SWITCH.

The HORN/SIREN switch, located on the left side of the front panel, activates the electronic air horn sound (up) or peak-and-hold sound (down) in any siren mode except radio.

### 4-5. TAP II FUNCTIONS.

Tap II allows the driver to change the audible siren sound via the vehicle's

horn ring. This feature is especially effective for clearing traffic. The chart below demonstrates how the horn ring can be used to change the siren sound:

TAP II FUNCTIONS		
Selector Switch Position	First Horn Ring Tap Produces	Second Horn Ring Tap Produces
Wail	Yelp	Wail
Yelp	Wail	Yelp

#### 4-6. PRESS AND HOLD FUNCTIONS.

Additional alternate sounds can be activated in two other Selector switch positions, by depressing and holding the horn ring for as long as the alternate sound is desired. The chart below shows these additional "Press and Hold" functions:

PRESS AND HOLD FUNCTIONS		
Selector Switch Position	Press on Horn Ring Produces	Release of Horn Ring Produces
Hi-Lo	Air Horn	Hi-Lo
Manual	Peak and Hold or Air Horn	Coast down and silence or silence

4194

## SECTION V CIRCUIT DESCRIPTION

### 5-1. GENERAL.

The Model PA300 circuitry can be divided into seven functional blocks. Refer to figure 5-1 and 6-4 while reading the following paragraphs.

### 5-2. RATE OSCILLATORS AND VOLTAGE CONTROLLED OSCILLATOR.

The heart of the Model PA300 circuitry is the rate oscillator and VCO sections. The rate oscillator not only determines the cycling rate of each siren tone, but also generates the control voltage that operates the voltage controlled oscillator (VCO). The VCO generates a square-wave output whose frequency is directly proportional to the control voltage. The output of the VCO is coupled to the siren's power output amplifier.

The siren rate oscillator consists of an LM556 dual timer configured as two astable oscillators. The first astable oscillator (IC12A) employs analog switches (IC10A, IC10B) to select the resistance for the RC timing network which determines the astable oscillator's cycling rate. IC10C, another analog switch, connects the discharge pin of IC12A to the RC timing network. When the peak function is called for, the control pin (IC10-6) goes low putting the switch in a high impedance state (OFF), and allows the RC rate capacitor (C11) to charge as the siren tone peaks.

IC12B, another astable oscillator, generates the control voltage required to generate the air-horn sound. Normally, IC 12B is held in the reset state (IC12-10 low) until the air horn control line is pulled high.

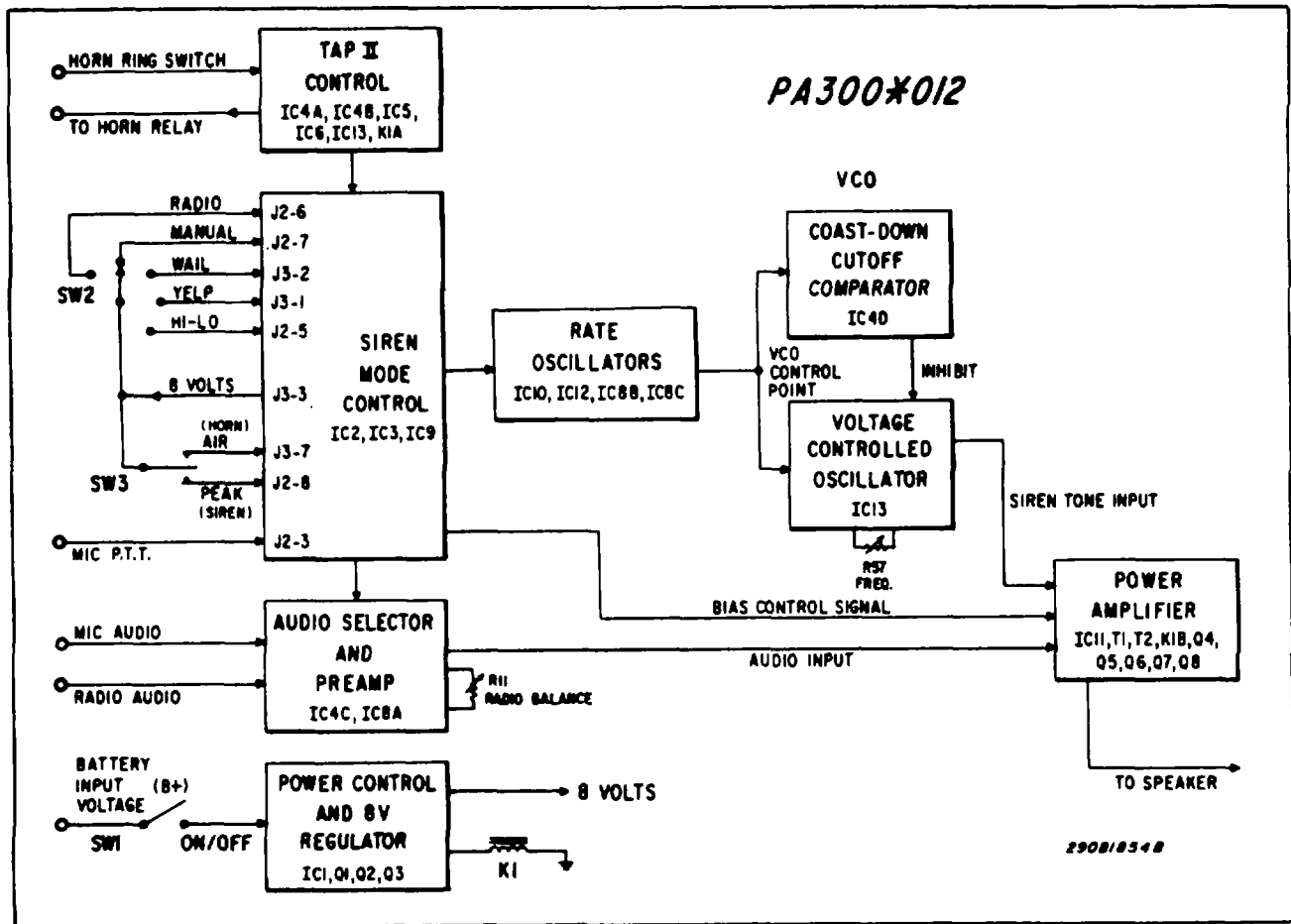

Figure 5-1. Function Block Diagram.

IC8C, a one-of-two analog switch, selects the siren or air horn control voltage from IC12A or IC12B. IC8B selects either the RC control voltage (manual, wail and yelp modes) or the square wave control voltage (hi-lo) derived from the output of IC12A. The voltage divider network of R27, R28, R29 and CR8 provides the DC level shifting of the IC 12A output necessary to obtain the desired hi-lo tone frequencies.

IC13, a phase-locked loop, contains the voltage controlled oscillator. C21, R46, R47, R57, and the control voltage on pin 9 determine the output frequency.

As the siren coasts down in the manual mode, the output of the VCO must be disabled to prevent frequencies lower than 350Hz from damaging the amplifier's output transistors. IC4D, a voltage comparator, compares the VCO control voltage to the low frequency reference voltage set by R40 and R41. When the VCO control voltage drops below the reference, IC4-8 goes high and forces the inhibit pin of the VCO high through OR gate IC9D. The VCO is also inhibited when the radio or microphone push-to-talk input is selected. These logic inputs are gated through IC7B, IC9C and IC9D to the VCO inhibit pin.

### **5-3. SIREN MODE CONTROL.**

The siren mode is controlled by the logic levels applied to J2-3, 5, 6, 7, 8 and J3-1, 2 and 7 (via Selector switch SW2), HORN/SIREN switch SW3, and the microphone push-to-talk switch. IC2 buffers the control inputs. IC3 and IC9 provide most of the decoding necessary to control the rate oscillator and analog switching of the audio and VCO control voltages.

### **5-4. TAP II CONTROL.**

As long as power is applied to the siren circuitry, the vehicle's horn ring switch will be connected through P3-5 and K1A to the inputs of a window comparator consisting of IC4A and IC4B. A positive or negative horn ring contact will result in a logic "1" pulse of equal duration at the junction of CR1 and CR2.

When the siren is in the wail or yelp mode, the horn ring pulse passes to the input of IC6A, is "debounced", and then applied to toggle flip-flop IC6B. Every time the horn ring is operated, the output of IC6B (pin 5) changes state and inverts the state of the yelp control line. (The exclusive OR gate contained in IC13 functions as a controlled inverter where a logic "1" present on pin 3 forces the output (pin 2) to Y or "yelp not".)

If the Selector switch mode is changed during a Tap II operation, the circuitry consisting of IC7A, IC5B and IC7C resets the toggle flip-flop (IC6B) and allows the true state of the yelp control line to pass to the rate oscillator section. This is necessary to insure that the Selector switch position corresponds to the audible siren tone produced.

### **NOTE**

The reset circuitry relies on the fact that the Selector switch is of the non-shorting type.

When the siren is in the manual mode, and JU1 and JU2 are left connected to "PEAK" (factory setting), the window comparator output will be passed through AND gate IC5C to activate the peak siren function, as long as the horn ring switch is depressed.

If manual or hi-lo is the selected mode and JU1 and JU2 are set to "AIR", the window comparator output will be passed through AND gate IC5D to activate the air horn override circuitry (refer to paragraph 5-2).

### **5-5. AUDIO SELECTOR AND POWER AMPLIFIER.**

The siren has two audio inputs: radio rebroadcast and microphone public address.

The radio input is derived from direct connection to the radio speaker. A fraction of the audio voltage developed across the radio balance potentiometer (R11) is applied to the input of a differential amplifier (IC4C). The differential

amplifier eliminates any ground reference problem that may exist between the PA-300 and various makes of radios. The microphone has a built-in transistor amplifier and therefore requires no external pre-amplifier. Resistor R14 serves as the collector bias resistor for the microphone's amplifier. The microphone output, derived from J2-1, and the radio audio from IC4C are selected via 1 of 2 analog switch IC8A. Normally, the microphone audio is gated through the multiplexer unless the Selector switch is set to the RADIO position. The selected audio is applied to IC11-2.

IC11 is an audio power amplifier integrated circuit which provides the necessary power gain to drive the push-pull amplifier stages beyond driver transformer T1. A biasing network consisting of TH1, CR15, Q4, R52, R53 and R54 is activated whenever the radio or the microphone push-to-talk switch is activated. This eliminates all "crossover" distortion associated with the push-pull output amplifier.

#### **5-6. 8-VOLT REGULATOR, POWER CONTROL AND HORN RING TRANSFER.**

When the GAIN control (on/off switch) is rotated clockwise, B+ is applied to the circuit board via J3-4 and J4-4. The networks consisting of CR4, C6 and CR10, R36, C17 provide filtering of the B+ voltage for the 8-volt regulator (IC1) and the audio amplifier (IC11). The large capacitances employed insure that all control logic remains stable and prevents "popping" noises heard through the loudspeaker when power is turned off.

Q1, Q2, Q3 and associated components form the power-on control circuitry. This network delays the activation of K 1 approximately one-second after B+ is applied. During the interim, all siren control logic stabilizes allowing C 15 to charge, bypassing the primary of driver transformer T1. This circuitry suppresses loud turn-on "thumps" from the loudspeaker and allows the vehicle horn ring switch to operate the siren's Tap II feature.

**4197**

**-11-**

**SECTION VI**  
**SERVICE AND MAINTENANCE**

**6-1. GENERAL.**

Most of the component electronic parts used in the Model PA300 are standard items that can be obtained from any radio or electronics supply shop. In order to reduce equipment down-time, Federal recommends that the entire printed circuit board (Part No. 200C860) be replaced. The printed circuit boards are relatively inexpensive allowing you to keep an adequate supply in your repair shop.

The diagrams in this section should be an aid to a repairman in isolating a malfunction and locating components.

The factory can and will service your equipment or assist you with technical problems, should any arise, that cannot be handled satisfactorily and promptly locally.

Communications and shipments should be addressed to:

Service Department  
Federal Signal Corporation  
2645 Federal Signal Drive  
University Park, IL 60466

If any unit is returned for adjustment or repair, it can be accepted only if we are notified by letter or phone in advance of its arrival. Such notice should clearly indicate the service requested and give all pertinent information regarding the nature of malfunction and, if possible, its cause.

**6-2. SIREN.**

A. General.

Any competent radio repairman or electronic technician should have little difficulty in tracing and correcting a malfunction, should any occur. For emergency replacement of any of the small components, care must be used when soldering. Heat easily impairs transistors capacitors and circuit boards. It is therefore

advisable to use longnose pliers or a similar heat sink on the lead being soldered.

If IC13 or C21 are replaced, it may be necessary to adjust R57. With the Selector Switch set to MANUAL, hold the paddle switch in the SIREN position and adjust R57 for 1400Hz at the siren output.

B. Removal for Servicing.

When removing the chassis for servicing, loosen the two hexagon head screws on the underside of the unit, near the front edge. Slide the entire chassis out of the case as shown in figure 6-1.

C. Removal of Circuit Board.

The PC board is secured to the chassis by four Phillips head screws. Unplug the four wafer connectors and microphone before removing the screws.

D. Replacement of Output Transistors

Failure of one or both of the out- put transistors (Q7, Q8) is usually the result of a defective speaker (short circuited voice coil). Rebroadcast of unscratched radio or music for long periods will also have a detrimental effect on the output transistors, and is therefore not recommended.

Federal recommends that both output transistors be replaced should only one device prove to be defective. This practice will ensure long periods of service between failures.

When installing new output transistors, ensure that the Sil-Pad insulators are installed between the heat-sink and transistors.

**CAUTION**

Make certain that the speaker is not defective prior to installing the repaired PA300.



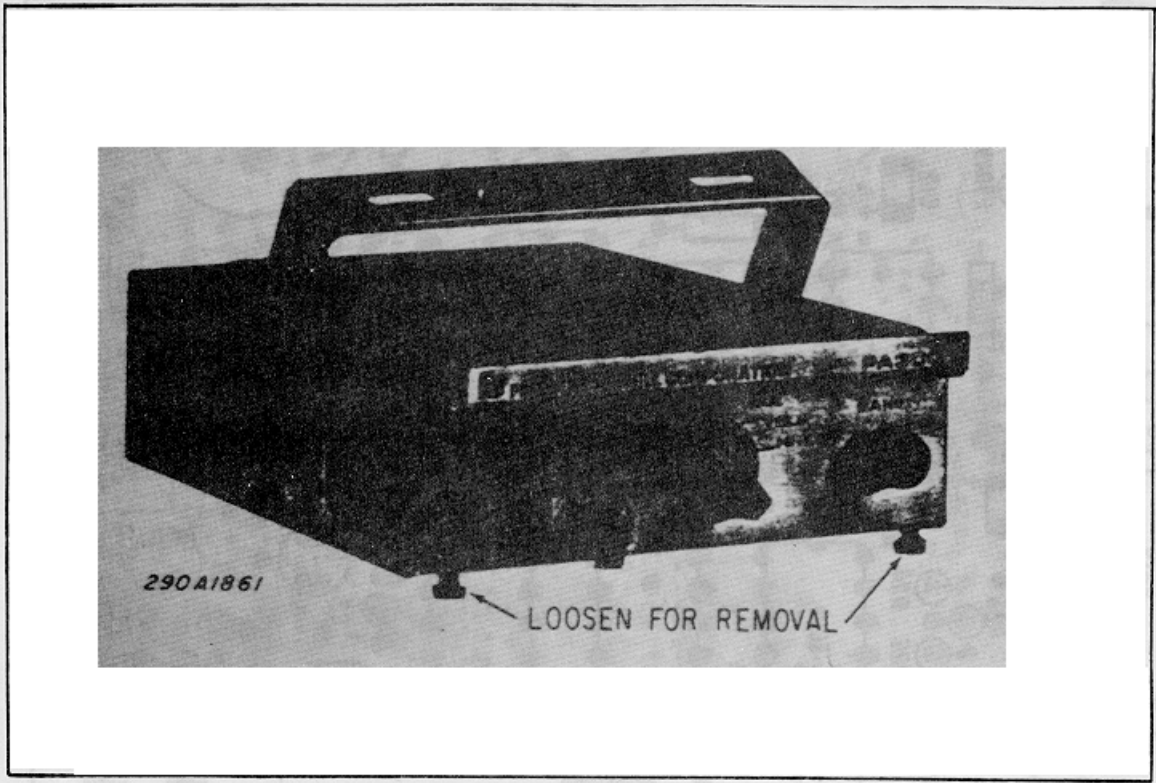

Figure 6-1. Chassis Removal.

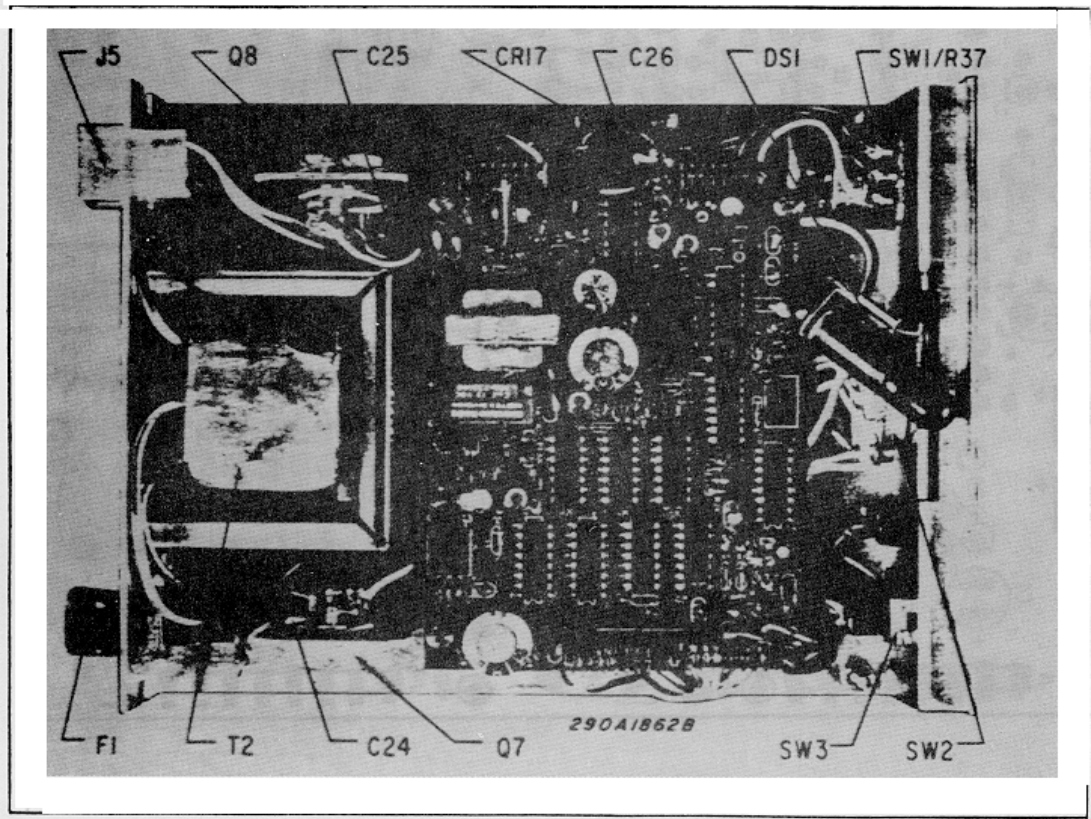

Figure 6-2. Internal View

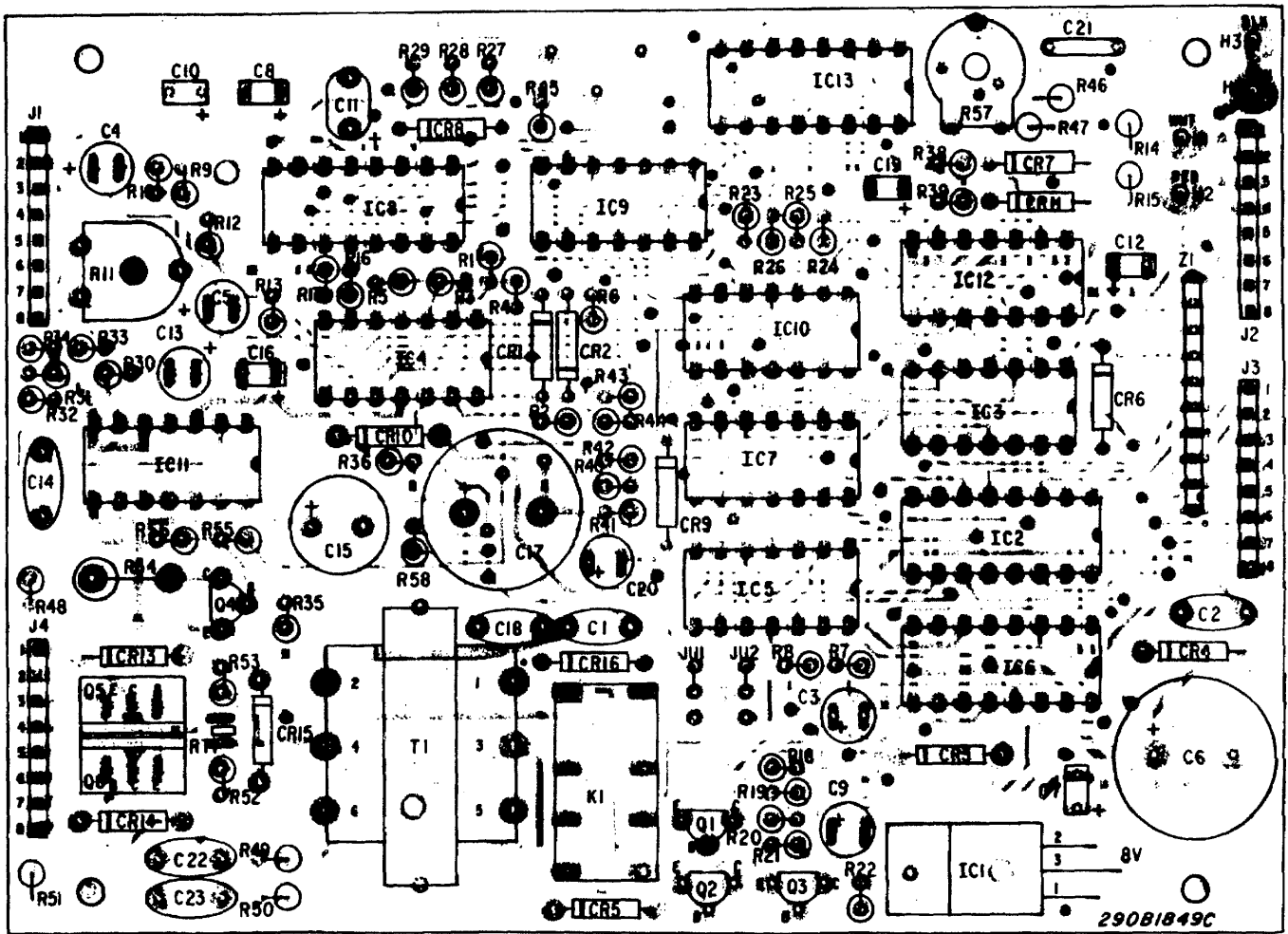

Figure 6-3. Component Location Diagram.

4200

-14-

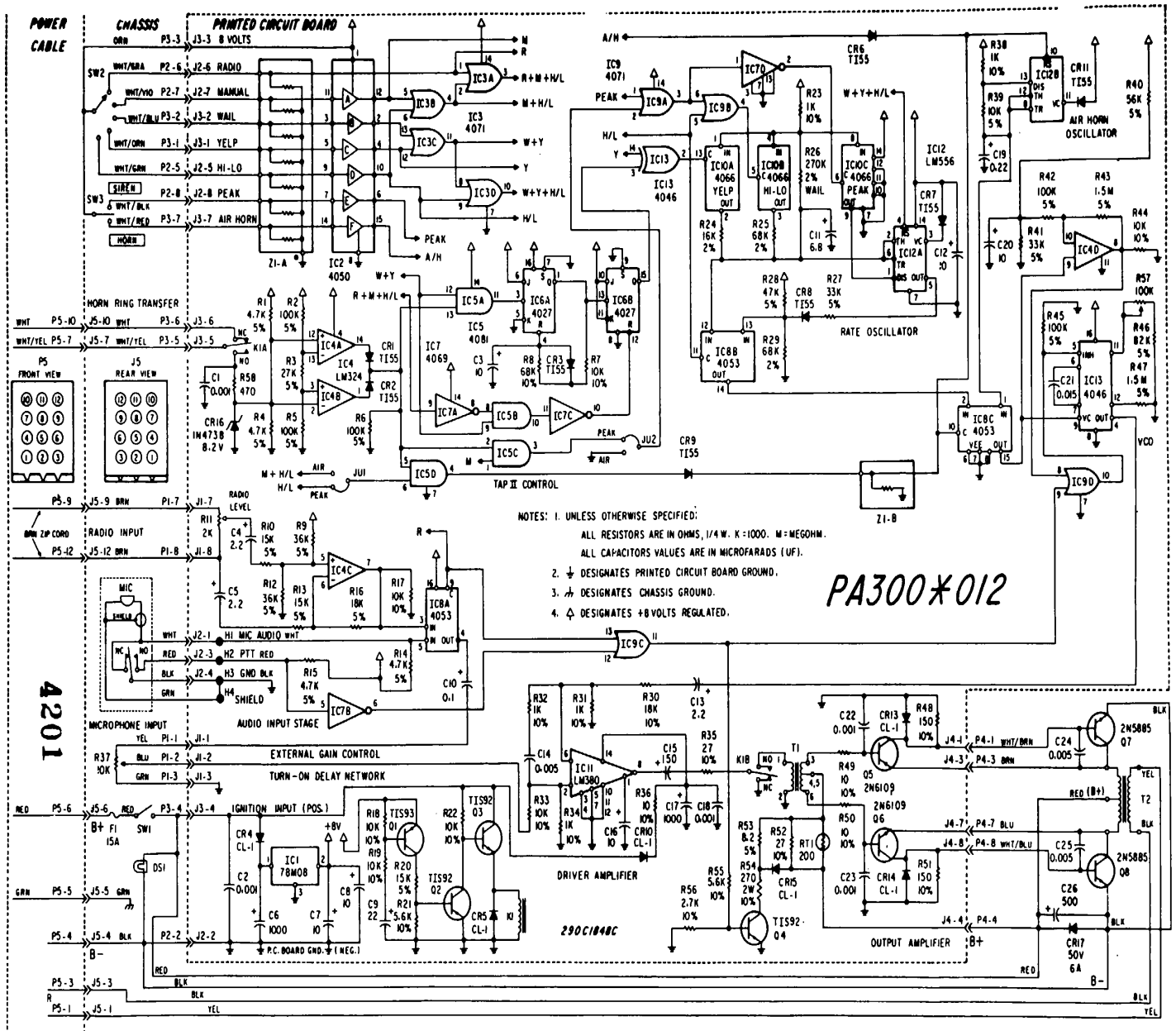

Figure 6-4. Schematic Diagram.

4201

**PARTS LIST**

<b>Schematic Symbol</b>	<b>Description</b>	<b>Part No.</b>	<b>Schematic Symbol</b>	<b>Description</b>	<b>Part No.</b>
	<b>*RESISTORS</b>			<b>INTEGRATED CIRCUITS</b>	
R1,4,14,15	4700 Ohm,5%	100A298	IC1	UA78MO8CKC	128A097
R2,5,6,42,45	100K Ohm,5%	100A262	IC2	CD4050BE	128A092A-01
R3	27K Ohm,5%	100A244	IC3,IC9	MC14071BCP	128B 082
R7,17,18, 19, 22, 33, 44	10K Ohm	100A207	IC4	LM324N	128A098
R8	68K Ohm	100A235	IC5	MC14081BCP	128A077
R9,12	36K Ohm,5%	100A709	IC6	MC14027BCP	128A044
R 10,13,20	15K Ohm,5%	100A239	IC7	MC14069UBCP	128A100
R11	2K Ohm, Potentiometer	106A203A-01	IC8	MC14053BCP	128A099
R16,30	18K Ohm,5%	100A258	IC10	MC14066BCP	128A047
R21,55	5600 Ohm	100A253	IC1i	LM380N	128A046
R23,31,32, 34,38	1000 Ohm	100A233	IC12	NAT LM556	128A038-01
R24	16K Ohm,2%	100A723	IC13	MC14046BCP	128B079
R25,29	68K Ohm,2%	100A775		<b>TRANSISTORS</b>	
R26	270K Ohm,2%	100A720	Q1	TIS93,PNP	125B133
R27,41	33K Ohm,5%	100A 771	Q2,3,4	TIS92,NPN	125B132
R28	47K Ohm,5%	100A701	Q5,6	2N6109,PNP	125B431
R35	27 Ohm	100A250	Q7,8	2N5885,NPN,Power	125B432
R36,49,50	10 Ohm	100A251		<b>MISCELLANEOUS</b>	
R37	10K Ohm, Potentiometer GAIN	106A116		Connector, Wafer	140A170
R39	10K Ohm, 5%	100A257	J1,2,3,4	Connector, 12-pin	139A152
R40	56K Ohm, 5%	100A704	J5	Terminal, Male	233A106
R43,47	1.5 Megohm, 5%	100A726	H 1,2,3,4	Plug,12-pin	140A154
R46	82K Ohm, 2%	100A750	P5	Relay,180 Ohm,12V, DPDT	131A130A-01
R48,51	150 Ohm	100A238	K1	Resistor Network, 9 x 10K	100A801
R52	27 Ohm	100A250	Z1	Termistor,200 Ohm	104A111
R53	8.2 Ohm, 5%	100A724	RT1	Transformer, Driver	120B 145
R54	270 Ohm, 2 watt, Wirewound	103A128	T1	Transformer, Output	120C151A-01
R56	2700 Ohm	100A206	T2	Fuse,15A,3AG, 32V	148A107
R57	100K Ohm,Potentiometer	106A203A-02	F1	8107A085	
R58	470 Ohm	100A255	Lamp,14V,#1893	122B215	
	*Unless otherwise specified, all RESISTORS are carbon type, +10%, 1/4 watt.	DS1 SW2	Switch, Rotary	Switch Paddle	122A214
	<b>CAPACITORS</b>		SW3	Terminal, Strip	229A127
			TB 1	Microphone	258B577
C1,2,18,22,23	0.001UF,500V,Disc	107A263		Socket, Transistor (Q7, Q8)	138A 125
C3,20	10UF,16V,Electrolytic	108A143		Socket, Lamp (DS1)	138A126B
C4,5,13	2.2UF,25V,Electrdytic	108A142		Holder, Fuse (F1)	143A106
C6,17	1000UF, 35V, Elecytic	108A149		Knob, GAIN control	141A102
C7,8,12,16	10UF,10OV,Tantalum	107A634		Knob, Selector	14IAIII
C9	22UF,16V,Electdytic	108A144		Insulator (Q7, Q8)	235A123A-01
C10	0.1UF,35V,Tantalum	107A1103		Circuit Board (without parts)	130C301B
C11	6.8UF,15V,Tantalum	107A604		Circuit Board (with parts installed)	200C860B
C14	0.005UF,1OOV,Disc	107A211		Standoff	230A123
C 15	150UF,16V,Elect-rytic	108A147		Bracket, Lamp	8536A025
C19	0.22UF,Radial Tantalum	107A1101		Bracket, Mounting	8536B 022
C21	0.15UF,5%,100V,Poly	107A766		Bracket, Transistor (Q7, Q8)	8537B303
C24,25	0.005UF, 100V,Disc	107A211			
C26	500UF, 15V,Electrolytic	108A122			
	<b>DIODES</b>				
CR1,2,3,6, 7,8,9,11	TI55	115B101			
CR4,5, 10, 13,14,15	ED3002S	115B301			
CR16	IN4738, 8.2V, Zener	115A232			
CR17	Rectifier, 6 amp.50V	115A317			

By Order of the Secretary of the Army:

Official:

R. L. DILWORTH  
*Brigadier General, United States Army*  
*The Adjutant General*

JOHN A. WICKHAM, JR.  
*General, United States Army*  
*Chief of Staff*

DISTRIBUTION:

To be distributed in accordance with Special List.

☆U.S. GOVERNMENT PRINTING OFFICE: 1"5 - 38421/01476

# The Metric System and Equivalents

## Linear Measure

1 centimeter = 10 millimeters = .39 inch  
 1 decimeter = 10 centimeters = 3.94 inches  
 1 meter = 10 decimeters = 39.37 inches  
 1 dekameter = 10 meters = 32.8 feet  
 1 hectometer = 10 dekameters = 328.08 feet  
 1 kilometer = 10 hectometers = 3,280.8 feet

## Weights

1 centigram = 10 milligrams = .15 grain  
 1 decigram = 10 centigrams = 1.54 grains  
 1 gram = 10 decigram = .035 ounce  
 1 dekagram = 10 grams = .35 ounce  
 1 hectogram = 10 dekagrams = 3.52 ounces  
 1 kilogram = 10 hectograms = 2.2 pounds  
 1 quintal = 100 kilograms = 220.46 pounds  
 1 metric ton = 10 quintals = 1.1 short tons

## Liquid Measure

1 centiliter = 10 milliliters = .34 fl. ounce  
 1 deciliter = 10 centiliters = 3.38 fl. ounces  
 1 liter = 10 deciliters = 33.81 fl. ounces  
 1 dekaliter = 10 liters = 2.64 gallons  
 1 hectoliter = 10 dekaliters = 26.42 gallons  
 1 kiloliter = 10 hectoliters = 264.18 gallons

## Square Measure

1 sq. centimeter = 100 sq. millimeters = .155 sq. inch  
 1 sq. decimeter = 100 sq. centimeters = 15.5 sq. inches  
 1 sq. meter (centare) = 100 sq. decimeters = 10.76 sq. feet  
 1 sq. dekameter (are) = 100 sq. meters = 1,076.4 sq. feet  
 1 sq. hectometer (hectare) = 100 sq. dekameters = 2.47 acres  
 1 sq. kilometer = 100 sq. hectometers = .386 sq. mile

## Cubic Measure

1 cu. centimeter = 1000 cu. millimeters = .06 cu. inch  
 1 cu. decimeter = 1000 cu. centimeters = 61.02 cu. inches  
 1 cu. meter = 1000 cu. decimeters = 35.31 cu. feet

## Approximate Conversion Factors

To change	To	Multiply by	To change	To	Multiply by
inches	centimeters	2.540	ounce-inches	newton-meters	.007062
feet	meters	.305	centimeters	inches	.394
yards	meters	.914	meters	feet	3.280
miles	kilometers	1.609	meters	yards	1.094
square inches	square centimeters	6.451	kilometers	miles	.621
square feet	square meters	.093	square centimeters	square inches	.155
square yards	square meters	.836	square meters	square feet	10.764
square miles	square kilometers	2.590	square meters	square yards	1.196
acres	square hectometers	.405	square kilometers	square miles	.386
cubic feet	cubic meters	.028	square hectometers	acres	2.471
cubic yards	cubic meters	.765	cubic meters	cubic feet	35.315
fluid ounces	milliliters	29.573	cubic meters	cubic yards	1.308
pints	liters	.473	milliliters	fluid ounces	.034
quarts	liters	.946	liters	pints	2.113
gallons	liters	3.785	liters	quarts	1.057
ounces	grams	28.349	liters	gallons	.264
pounds	kilograms	.454	grams	ounces	.035
short tons	metric tons	.907	kilograms	pounds	2.205
pound-feet	newton-meters	1.356	metric tons	short tons	1.102
pound-inches	newton-meters	.11296			

## Temperature (Exact)

°F Fahrenheit temperature      5/9 (after subtracting 32)      Celsius temperature      °C

RECOMMENDED CHANGES TO EQUIPMENT TECHNICAL PUBLICATIONS



THEN... JOT DOWN THE DOPE ABOUT IT ON THIS FORM, CAREFULLY TEAR IT OUT, FOLD IT AND DROP IT IN THE MAIL!

**SOMETHING WRONG WITH THIS PUBLICATION?**

FROM: (PRINT YOUR UNIT'S COMPLETE ADDRESS)

DATE SENT

PUBLICATION NUMBER

PUBLICATION DATE

PUBLICATION TITLE

BE EXACT... PIN-POINT WHERE IT IS

PAGE NO.	PARA-GRAPH	FIGURE NO.	TABLE NO.

IN THIS SPACE TELL WHAT IS WRONG AND WHAT SHOULD BE DONE ABOUT IT:

TEAR ALONG PERFORATED LINE

PRINTED NAME, GRADE OR TITLE, AND TELEPHONE NUMBER

SIGN HERE:

DA FORM 1 JUL 79 2028-2

PREVIOUS EDITIONS ARE OBSOLETE.

P.S.—IF YOUR OUTFIT WANTS TO KNOW ABOUT YOUR RECOMMENDATION MAKE A CARBON COPY OF THIS AND GIVE IT TO YOUR HEADQUARTERS.

**PIN: 059727-000**